



Installation Manual	
Part No.	Description
PWE Series	LLS Portable Winch Exposed

BY	REVISION	DATE
VICTOR MEZA	B	8/22/23

INSTALLATION AND OPERATING MANUAL FOR: PWE SERIES FOR INDOOR MANUAL SYSTEMS

◆ GENERAL NOTES AND COMMENTS	1
◆ INSTALLATION INSTRUCTIONS FOR INDOOR SYSTEMS	2
◆ CABLE CLAMP INSTRUCTIONS	2
◆ LOWERING & RAISING OPERATING INSTRUCTIONS	3
◆ PREVENTATIVE MAINTENANCE	4

SAFETY WARNING

Please follow all state and local safety regulations while you are performing this work. Reading and understanding this manual will significantly reduce the risk of injury.

GENERAL NOTES AND COMMENTS

Our raising and lowering system incorporating contact suspension units (SCU) gives locked suspension, which insures that the full weight of the light fixture is carried by the contact suspension unit relieving the lowering tool, pulleys, and wire rope from tension. These in fact only come under tension during actual raising and lowering. It should be borne in mind however, that even when the contact suspension unit is in the locked position, the lowering cable is attached to the lowering tool or the eyebolt, giving the unit a secondary lock.

When electrical connection is broken during unlocking and lowering, no live electrical wires are lowered with the fixture.

The light fixture can conveniently be lowered to floor level, by one man without necessity for ladders, scaffolding, etc.

A threaded stem is provided with the lowering device. An eye-loop can also be provided. In very special conditions, other methods of mounting can be furnished. We would ask you to keep us informed of any special installations in this respect.

BASIC FACTS

1. Read all instructions. If you do not understand part of it, call your Sales Rep. or the factory.
2. The SCU must be mounted on a **level, horizontal** surface. The SCU **should not be mounted to unistrut** or other structural material that can move while the fixture is raised or lowered.
3. The SCU must be fixed vertically and rigid.
4. The luminaires must be balanced vertically in any radial position. Center of gravity must be in the center of the SCU mounting adapter. Balance of the luminaire is important, otherwise difficulty could arise in locking and unlocking.
5. All fixtures must be hung by at least 3 chain links. The operator must always stop raising the about 12" from the locked position. This allows the fixture to rotate on its own, decreasing the stress. When the fixture stops moving, continue the **raise** position to the top.
6. The contact unit must have a minimum weight of 30 pounds (additional weight can be supplied).

7. Every specification or order must include mounting height, distance fixture is being lowered, and distance from the SCU to the wall.

MATERIAL NOT SUPPLIED

1. Any electrical wiring (unless specified).
2. Cable glands, or cable relieves.
3. Mounting bolts, brackets to support SCU.
4. We make no recommendations for electric wiring, which will vary from customer to customer, and local and national codes.
5. Circuit breakers.
6. Fixtures unless purchased from us.

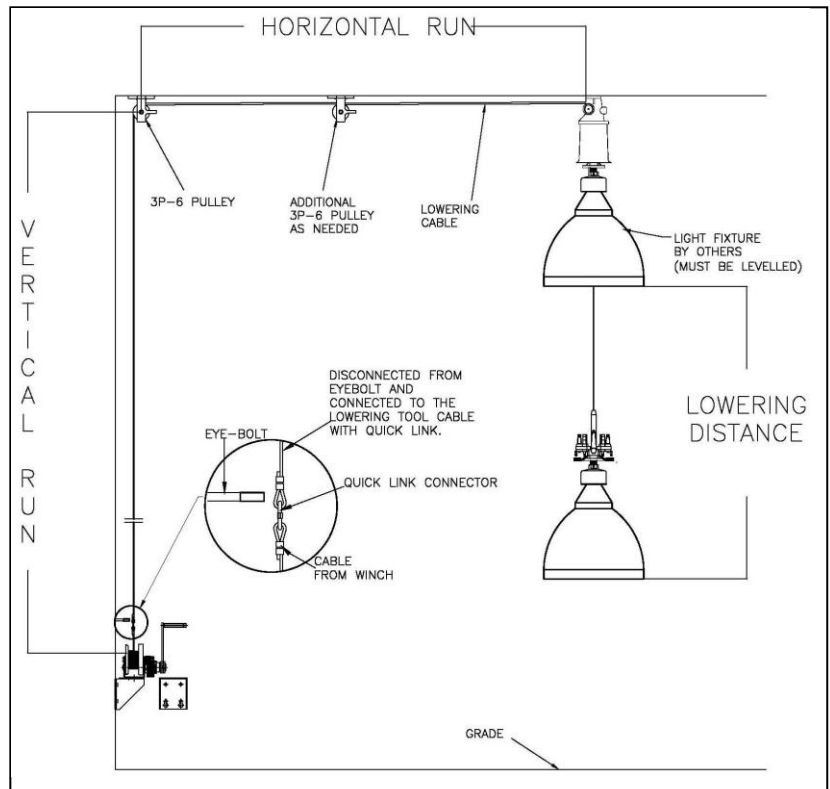

MATERIAL SUPPLIED

1. All lowering cables will be precut and crimped by factory or wire rope will be supplied on a reel for cutting on site if preferred by customer.
2. Pulleys, Termination Points, and Lowering Tools.
3. Specified bottom attachment will be provided to match luminaire or canopy fitting. Engineer must provide us with details including type and weight of luminaire to be used. The SCU-2A Disconnect Unit is supplied with 4 contacts; in addition, a green ground screw attached to the casting. Optional up to 8 contacts can be provided for multiple circuits. The SCU-2X disconnect unit is fitted with 9 contacts plus ground.

INSTALLATION INSTRUCTIONS FOR INDOOR SYSTEMS

1. Before any mechanical or electrical connections are made, the suspension contact unit (SCU) must be mounted to beams and fully tightened. **THIS MUST BE DONE WITH THE UTMOST CARE.** The unit must be hung in a vertical position (plumb) and stationary.
2. The SCU is comprised of a **fixed** assembly and a **moveable** assembly.

SCU-2A-PWE400 SYSTEM

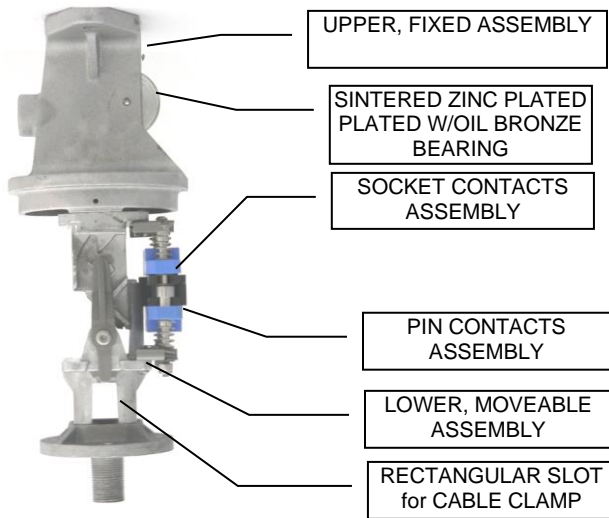

Fixed Assembly is bolted to beam (or other support). It remains fixed. It incorporates the socket electrical contacts and the “locking cam track”. The electrical cables are fed from this assembly to a nearby junction box (by others).

Moveable Assembly is the assembly, which is lowered to the floor with the fixture. The lighting fitting is connected to the bottom of this assembly by means of threaded adaptor, shackle, flange, canopy, or rigid conduit. This assembly incorporates the pin contacts, the locking cams, and guiding pin. It is to this assembly that the wire rope terminates by means of the cable clamp.

3. Unwind Lowering Cable-CAUTION: DO NOT KINK THE CABLE. See page on “RIGHT” and “WRONG” ways of handling cable.
4. **Pulley Mounting-** it is important that pulleys are properly aligned when installing. It is also important to ensure that pulleys are not fitted too close to winches (lowering tools) as the

rope plays back and forth on the winch drum. Pulleys should be at least 3ft or further and mounted in line to the center of the winch drum. If pulleys are too close, then bunching occurs and/or rope wear due to rope tending to “pull off” pulley wheel. Do not use them in dirty atmospheres.

5. Always consider pulley friction if loads are near limits of winch.
6. The minimum number of pulleys, additional to the pulley in the SCU, should be used to change direction of the wire as each pulley can increase the pull on the winch by 8% cumulative due to friction. (It is important to ascertain appropriate pulley type based on pullout force acting on pulley and nature of material on which pulley is being secured to.) Accurate alignment of pulleys and structure that pulleys are mounted to, are vital.
7. Wire in straight runs should be supported by pulleys at intervals preferably not more than 30ft (10M).
8. The distance between the winch (lowering tool) and the first pulley should be 3ft or greater.
9. The winch should be fitted in the most convenient position to suit the site and environment. The wire rope traversing from winch over pulleys to contact suspension unit must be correctly aligned.
10. The Lowering Tool is to be firmly fixed with sufficient space to allow handle to be turned and removed.
11. Check to be sure that all contacts and insulator are in good condition and tight. This is most important on fixed section, which is inaccessible after assembly.
12. Attach the connecting link on the crimped end of the cable to the Eye-bolt.
13. Pass lowering cable thru the pulleys mounted between the Eye-bolt and the SCU.
14. Pass lowering cable into the pulley in the SCU. Remove outer cover from the contact suspension unit (SCU).
15. Push lowering cable down center of **guiding pin**, and out through **rectangular slot** opening in the **lower assembly**.
16. Fit rope clamp to lowering cable. Tighten screws on rope clamp to allow it to fit into **rectangular slot**. You must follow the drawing the exact way.

CABLE CLAMP

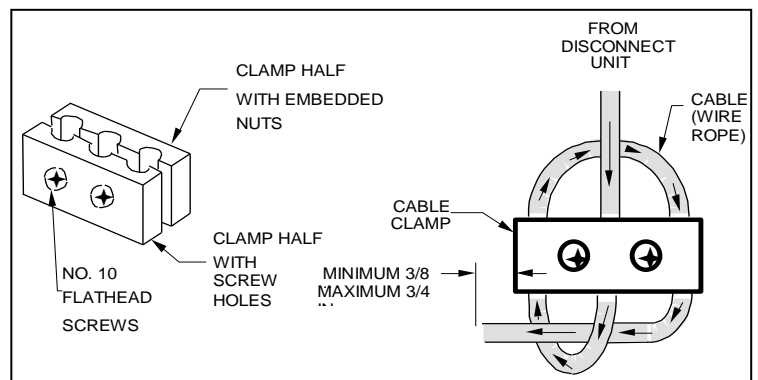

17. Fit rope clamp to **rectangular slot**. Pull lowering cable to remove slack and align cable clamp to fit properly in **slot**. If all is

correct, tape and cut spare cable at clamp.
Leave 1/2" of cable sticking out of clamp.

18. Push up bottom contact and leave in locked position.
19. There should be 1 1/2-2" of slack in the cable when the disconnect unit (SCU) is locked.
20. If you have a greater amount of slack, tape the cable and cut extra cable off.
21. Connect the electrical wires from the fixture to the wires from the Disconnect Unit.

LOWERING AND RAISING OPERATING INSTRUCTIONS

TURN OFF ELECTRICAL SUPPLY BEFORE OPERATING. DO NOT USE CONTACT UNITS AS SWITCHES.

TO LOWER FIXTURE

1. First, ensure there is a minimum of two dead turns of wire rope, (about 5ft) on the drum plus the distance from the fixture to the floor. It is essential that at EVERY hoisting operation, the first full layer of wire rope be uniformly fed onto the drum. This will assist in preventing bunching of the rope. Attention MUST be paid throughout the entire hoisting to ensure bunching of wire rope on the winch is avoided.
2. Make sure there is at least 30 lbs of weight attached to the disconnect unit (SCU).
3. Insert handle in winch and wind up until additional tension is felt on the winch. The fixture raises about 3/4" to unlock from the locking cams. Then reverse direction and lower the fixture to recommended height.

TO RAISE FIXTURE

1. First, insure there is a minimum of two dead turns of wire rope, on the drum. It is essential that at EVERY hoisting operation, the first full layer of wire rope be uniformly fed onto the drum. This will assist in preventing bunching of the rope. Attention MUST be paid throughout the entire hoisting to ensure bunching of wire rope on the winch is avoided.
2. Wind up fixture to the top. TAKE CARE OVER THE LAST FOOT as guiding pin starts turning to align contacts and locking cams. ONE FOOT from the top, STOP upward movement of fixture. Allow fixture to settle down and stop rotating. Once fixture has stopped, continue upward movement. This is particularly important with rigid mount fixtures (non-chain or cable hung). This warning applies for both motorized and manual crank systems. If guiding pin fails to

enter, re-lower and check the lines of balance. Raise fixture again.

3. When the luminaire is raised up, the operator should exercise extra-ordinary care and avoid undue or excessive swing or spin of the fitting as the moveable assembly approaches the bottom of the contact suspension unit. The operator should "feel his way" to engage the guide pin smoothly into the guide. He should wind carefully and again feel for the stop. One turn or so of the winch handle in the opposite direction (lowering the fixture) will then lock the moveable assembly in position and leave it suspended to the mechanism inside the contact suspension unit and electrically contacted. The lowering cable then becomes slack. ALWAYS CHECK THAT THE LOWERING CABLE IS SLACK BEFORE YOU LEAVE IT.
4. You then know that the fitting is suspended by the unit and is not suspended by the winch rope.
5. When completed, re-energize the fixture and make sure it is working properly.
6. Disconnect lowering cable from the GB-2P lowering tool and connect the link to the Eye-bolt parking stand on the wall.

PWE400-XXX SYSTEM

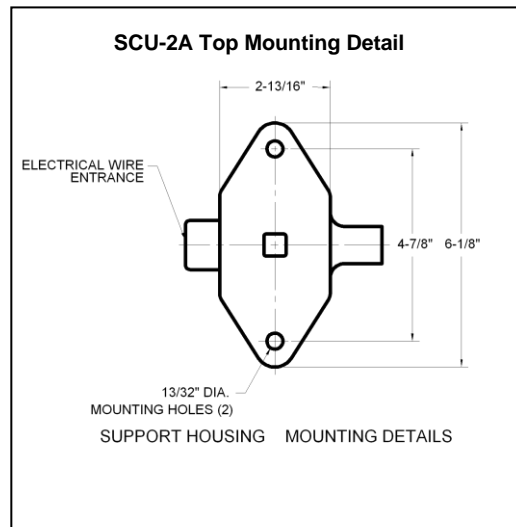

PREVENTATIVE MAINTENANCE

Upon installation of the system, periodic preventive maintenance should be done to the system. The following is a list of preventative maintenance operations and schedule:

LOWERING TOOL

- 1. The tool should be kept in a clean and dry area.**
- 2. During every usage of the Lowering Tool, the raising and lowering cable should be checked for kinks, cut strands, and any irregularities, each time the tool is used.**
- 3. The gears on the winch should be checked for gearing grease. If the gear box looks dry, gear grease should be applied on the gears only, with a small paint brush. The grease should be applied liberally covering all gears. Recommended grease should be UNIWRI 2 product #C163520 Manufactured by: Fuchs Lubricants. (PH: 800-800-OILS) This grease can be obtained through Camera Lowering Systems.**
- 4. A drop of 10W-30 oil should be applied in opening of casement (see sign on winch). Only apply one drop annually. After applying, crank the winch at least 3 revolutions to distribute the oil.**
- 5. Check the cable for any kinks, bends, or stray cut wires. This will tell you if cable is rubbing on an obstruction. If cable is damaged, it will weaken the cable, possibly causing the cable to break. Damaged cables should be replaced. See attached “cable handling” page. Handle wire rope with gloves to avoid possible hand cuts caused by stray wires.**

DISCONNECT UNIT

- 1. Each time the disconnect unit is lowered, check the condition of the system. If there are any signs of irregularities, contact the factory.**
- 2. Keep the guide pin and “rest button” on the locking cams cleaned and well lubricated with: ‘Super Lube multipurpose grease with Syncolon, manufactured by SYNCO CHEMICAL CORP’ or equivalent.**
- 3. The locking cams should be checked each time the camera is lowered. Ensure that the shoulder screw is tightened.**
- 4. Check all screws, nuts and fastenings are tight.**
- 5. Check composite cable for any irregularities.**