



Installation Manual	
Part No.	Description
ECS-400	ENCLOSED CABLE SYSTEM (ECS-400)

BY	REVISION	DATE
DONALD PIKE	B	8/22/2023

INSTALLATION AND OPERATING MANUAL FOR:

ECS-400

FOR INDOOR ENCLOSED CABLE SYSTEMS

◆ GENERAL NOTES AND COMMENT	1
◆ INSTALLATION INSTRUCTIONS	2
◆ CABLE ORIENTATION OPTIONS	3
◆ CABLE CLAMP INSTRUCTIONS	4
◆ SPECIFICATIONS	5
◆ SLB-3 SECURITY LOCK BOX INSTALLATION	6
◆ LT-4 LOCKING BOX LOWERING TOOL	7
◆ CABLE HANDLING	8
◆ PREVENTATIVE MAINTENANCE	9

SAFETY WARNING

Please follow all state and local safety regulations while you are performing this work. Reading and understanding this manual will significantly reduce the risk of injury.

GENERAL NOTES AND COMMENTS

Our raising and lowering system incorporating contact suspension units (SCU) gives locked suspension, which ensures that the full weight of the light fixture is carried by the contact suspension unit relieving the lowering tool, pulleys, and wire rope from tension. These in fact only come under tension during actual raising and lowering. It should be borne in mind however, that even when the contact suspension unit is in the locked position, the lowering cable is attached to the lowering tool or the eyebolt, giving the unit a secondary suspension.

When electrical connection is broken during unlocking and lowering, no live electrical wires are lowered with the fixture.

The lighting fitting can conveniently be lowered to the ground by one man without necessity for ladders, scaffolding, etc.

In very special conditions, other methods of mounting can be furnished. We would ask you to keep us informed of any special installations in this respect.

BASIC FACTS

1. Read all instructions. If you do not understand part of it, call your Sales Rep. or the factory.
2. The SCU must be mounted on a **level, horizontal** surface.
3. The SCU must be fixed vertically and rigid.
4. The luminaires must be balanced vertically in any radial position. Center of gravity must be in the center of the SCU mounting adapter. Balance of the luminaire is important, otherwise difficulty could arise in locking and unlocking.

When using a rigid fixture (non-chain hung), always stop fixture while **raising**, about 6" from the locked position. This allows the fixture to rotate on its own, until it reaches the resting position. When the fixture stops moving, continue **raising** the fixture to the top.

5. The contact unit must have a minimum weight of 20 pounds (30 pounds for multiple circuits). Additional weight can be purchased from the factory.
6. Every specification or order must include mounting height, distance fixture is being lowered, and distance from the contact to the wall.

MATERIAL NOT SUPPLIED

1. Any electric wiring (other than noted below).
2. Cable glands, or cable relieves.
3. Mounting bolts, brackets to support SCU.
4. We make no recommendations for electric wiring, which will vary from customer to customer, and local and national codes.
5. Circuit breakers, junction boxes.
6. Fixtures unless purchased from North Star Lighting.

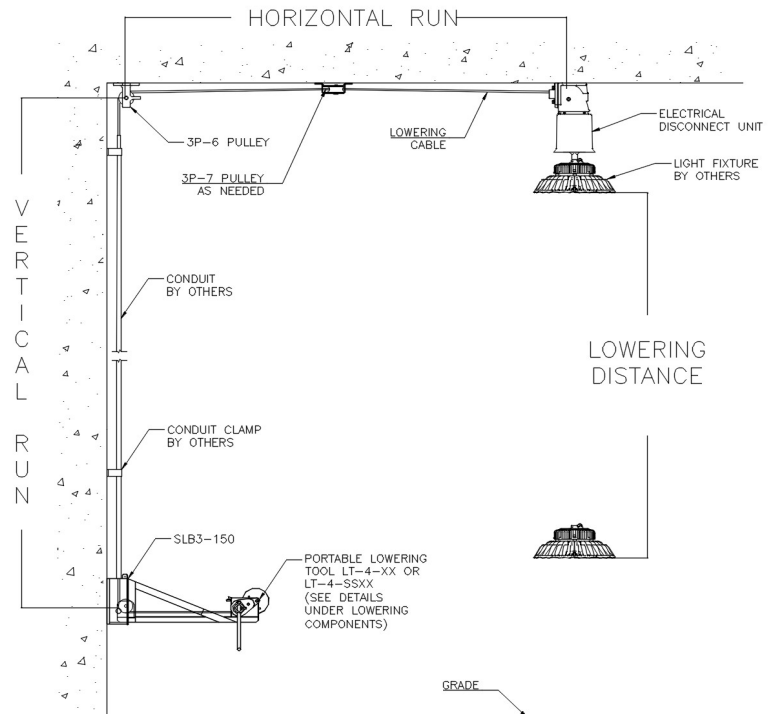

MATERIAL SUPPLIED

1. All lowering cables will be precut and crimped by factory. Optional, wire rope will be supplied on a reel for cutting on site if preferred by customer.
2. Pulleys, Termination Points, and Lowering Tools.
3. Specified bottom attachment will be provided to match luminaire or canopy fitting. Engineer must provide us with details including type and weight of luminaire to be used.
4. The SCU-2A Disconnect Unit is supplied with 4 wire leads attached to the 4 contacts. In addition, a green ground (earth) wire is attached to a green screw on the casting. Optional up to 8 contacts can be provided for multiple circuits.
5. Electrical Wire leads out of the top casting.

INSTALLATION INSTRUCTIONS FOR INDOOR ENLCOSED CABLE SYSTEMS

1. Before any mechanical or electrical connections are made, the suspension contact unit (SCU) must be mounted to beams and fully tightened. **THIS MUST BE DONE WITH THE UTMOST CARE.** The unit must be hung in a vertical position (plumb) and stationary. The unit must be level in all directions.

2. The SCU is comprised of a **fixed** assembly and a **moveable** assembly.

The Fixed Assembly is bolted to beam (or other support). Contact structural engineer for proper mounting structure for the SCU and all other parts. Due to increased torque while raising and lowering, the structure cannot move in any direction. It must remain rigid for the system to operate properly. The top portion remains fixed. It incorporates the socket electrical contacts and the "locking cam track". The power cables are fed from this assembly and out the conduit opening.

SCU-2A Top Mounting Detail

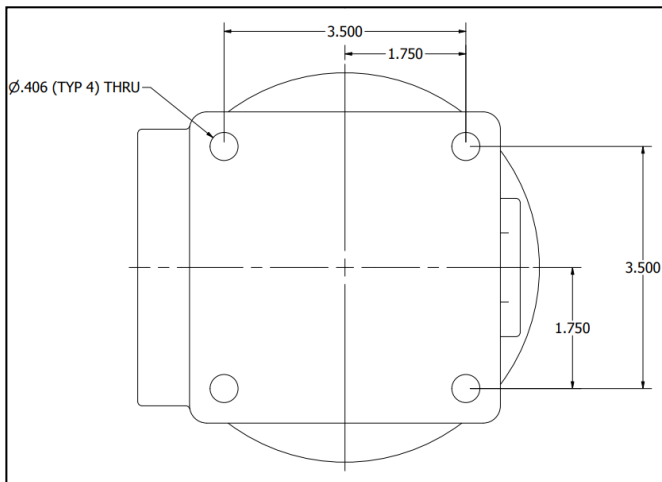

The Moveable Assembly is the assembly, which is lowered to the floor with the fixture. The lighting fitting is connected to the bottom of this assembly by means of threaded adaptor, shackle, flange, canopy, or rigid conduit. This assembly incorporates the pin contacts with wire leads, the locking cams, and guide pin. It is to this assembly that the wire rope terminates by means of rope clamps.

3. Unwind Lowering Cable-**CAUTION: DO NOT KINK THE CABLE.** See page on "RIGHT" and "WRONG" ways of handling cable.

4. **Pulley Mounting-** it is important that pulleys are properly aligned when installed. It is also important to ensure that pulleys are not fitted too close to winches (lowering tools) as the rope plays back and forth on the winch drum. Pulleys should be at least 3ft and mounted in the center of the winch drum. If pulleys are too close, then bunching occurs and/or rope wear due to rope tending to "pull off" pulley wheel. Do not use them in dirty atmospheres. Always consider pulley friction (10% per pulley) if loads are near the limits of the winch (400 LBS for **ECS400**).

5. The minimum number of pulleys, additional to the pulley in the SCU, should be used to change direction of the wire as each pulley can increase the pull on the winch by 10% cumulative due to friction. (It is important to ascertain appropriate pulley type based on pullout forces acting on pulley and nature of material on which pulley is being secured to.) contact Structural Engineer for advice. Accurate alignment of pulleys in relationship to each other, SCU, and Winch, are vital.

6. Wire in straight horizontal runs should be supported by pulleys at intervals of 30ft (10M) or less.

7. The distance between the winch (lowering tool) and the first pulley should be 3ft or greater.

8. The portable LT-4 lowering tool should be bolted to the SLB3-150 security locking box. The wire rope traversing from the winch on the LT-4 should be attached to the wire rope coming down the wall from the SCU-2A with the connecting link.

9. For security purposes, 1" conduit should be attached to the SLB3-150 locking box and run up the wall. Conduit standoffs should be used to support the conduit from the wall every 10ft or more if necessary.

10. On the SCU disconnect unit, check to be sure that all contacts and insulators are in good condition and tight. This is most important on fixed section, which is inaccessible after assembly.

11. An Electrical junction box should be mounted close to the fixed portion of the SCU-2A. Wires from the SCU should run inside conduit to the junction box. While in the raised (locked) position, test continuity circuit from the junction box to the wire leads from the lower half.

12. Raising and lowering cable comes attached to the SCU-2A. The cable is attached to the rope clamp in the SCU-2A disconnect unit. After uncoiling the raising and lowering cable, feed the cable thru the pulley assemblies horizontally and vertically, thru the conduit, terminating in the SLB3-150.

13. Attach the cable quick link to the eye-bolt in the SLB3-150.

14. In the SCU, remove the Cable Clamp from the rectangular slot and loosen the 2 flathead screws. See drawing on following page.

15. If cable is not attached, run cable over pulley in SCU. Remove outer cover from contact suspension unit if necessary.

16. Feed lowering cable through center of locking cam block.

17. Push lowering cable down center of **guiding pin**, and out through **rectangular slot** opening.

18. Fit rope clamp to lowering cable. Tighten screws on rope clamp to allow it to fit into **rectangular slot**. You must follow the drawing the exact way.

19. Fit rope clamp to **rectangular slot**. Pull lowering cable to remove slack and align cable clamp to fit properly in **slot**. If all is correct, tape and cut spare cable at clamp. Leave 1/2" of cable sticking out of

clamp. There should be about 3" of slack in the cable before cutting the cable.

ROPE CLAMP

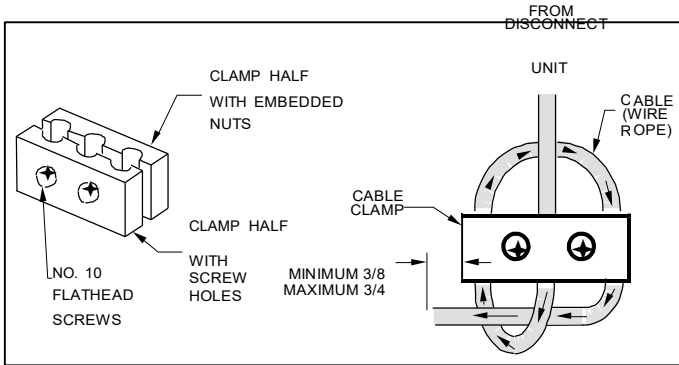

20. Push up bottom contact and leave in lock position. There should be enough slack on the cable.

21. Now contact is mounted. You can mount "connector link". There should be a little slack in the cable when the disconnect unit (SCU) is locked. Wire up luminaires with wire leads coming from the pin contact half of the disconnect unit, and attach to the fixture.

LOWERING AND RAISING OPERATING INSTRUCTIONS

TURN OFF ELECTRICAL SUPPLY BEFORE OPERATING. DO NOT USE CONTACT UNITS AS SWITCHES.

TO LOWER FIXTURE

1. First, ensure there is a minimum of two dead turns of wire rope, on the drum. It is essential that at EVERY hoisting operation, the first full layer of wire rope be uniformly fed onto the drum. This will assist in preventing bunching of the rope. Attention MUST be paid throughout the entire hoisting to ensure bunching of wire rope on the winch is avoided.

2. Mount the proper lowering tool and connect cable from the gearbox to the fixture cable-connecting link. There should be no tension on the lowering cable.

3. Insert handle in winch and wind up until additional tension is felt on the winch. The fixture raises about 3/4" to unlock from the locking cams. Then reverse direction and lower the fixture to recommended height. The maximum distance that the fixture can be lowered is from the Lowering Tool to the first pulley assembly. The cable-connecting link will not penetrate through the

pulley Assy. unless the 3P-6 pulley is used. The connection link will pass through the 3P-6 housing.

TO RAISE FIXTURE

1. First, insure there is a minimum of two dead turns of wire rope, on the drum. It is essential that at EVERY hoisting operation, the first full layer of wire rope be uniformly fed onto the drum. This will assist in preventing bunching of the rope. Attention MUST be paid throughout the entire hoisting to ensure bunching of wire rope on the winch is avoided.

2. Wind up fixture to the top. TAKE CARE OVER THE LAST FOOT as guiding pin starts turning to align contacts and locking cams. STOP upward movement of fixture. Allow fixture to settle down and stop rotating. Once fixture has stopped, continue upward movement. This is particularly important with rigid mount fixtures (non-chain or cable hung). This warning applies for both motorized and manual crank systems. If guiding pin fails to enter, re-lower and check the lines of balance. Raise fixture again.

3. When the luminaire is raised up, the operator should exercise extra-ordinary care and avoid undue or excessive swing or spin of the fitting as the moveable assembly approaches the bottom of the contact suspension unit. The operator should "feel his way" to engage the guide pin smoothly into the guide. He should wind carefully and again feel for the stop. One turn or so of the winch handle in the opposite direction (lowering the fixture) will then lock the moveable assembly in position and leave it suspended to the mechanism inside the contact suspension unit and electrically contacted. The lowering cable then becomes slack. ALWAYS CHECK THAT THE LOWERING CABLE IS SLACK BEFORE YOU LEAVE IT.

4. You then know that the fitting is suspended by the unit and is not suspended by the winch rope. The fixture cable should be disengaged from the Lowering Tool cable. The fixture cable should then be attached to the termination point (Locking Eye bolt). Remove the Lowering Tool and proceed to the next fixture.

The fixture lowering cable should be attached to the winch cable with the connecting link (see below):

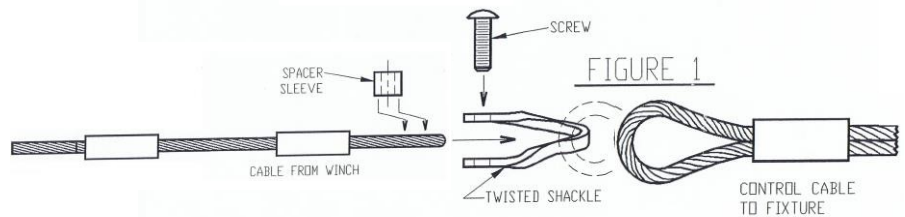

SPECIFICATIONS

❖ The EDU shall have a 3-way tracking guide and support. It shall be constructed of precision cast high strength aluminum alloy 356-T6. A permanently fixed position piece incorporating a special tracking guide system permits the moveable portion of the *Disconnect Unit* to align in the same position every time the system is operated, thereby eliminating the need to re-orientate the fixture. The Electrical Disconnect Unit shall have twin high strength stainless steel locking cams securing the load of the *Lower Contact Assembly* and fixture. All tension on the cable is relieved when the fixture is in the raised position.

❖ The MULTI-CONTACT Connector assembly shall be modular for easy installation and retrofit requirements. All **pin and socket contacts** shall be insertable and removable. The connector shall also have 2 size 12 contacts. Material of contacts shall be copper with nickel plating, and with gold plating over nickel per MIL-G-45204. Electrical contacts shall have a rating of 20 year mean time between failures. All hardware shall be corrosion resistant stainless steel. It shall have a self-aligning and self-adjusting mechanical system comprised of two principal assemblies:

The UPPER CONTACT HALF (Fixed) shall house the socket contacts. It shall incorporate spring assisted polymer contact body with precision-machined stainless steel guideposts. The socket contact body shall have integral guideposts for precise contact alignment.

The LOWER CONTACT HALF (Moveable) shall house the pin contacts comprised of spring assisted polymer contact body with precision-machined stainless steel guidepost receivers. The pin contact body aligns with guideposts of integral socket body guideposts.

❖ The wire leads are potted in Superflex® Black RTV Silicone, an industrial grade sealant for bonding and sealing.

❖ The unit shall have a guidepost constructed of precision cast high strength stainless steel. It shall utilize a cast-in-place guide bar for precise alignment of *Lower Contact Assembly* with the fixed portion of the *EDU*.

❖ The **EDU shall have** twin (2) tracking support arms made of precision cast high strength stainless steel. When locked in the *3-Way Tracking Guide and Support* notches, the *Twin Tracking/Support Arms* shall hold the weight of the fixture and components and it shall remove all tension from the *Control Cable or Lowering Cable*.

❖ The lower contact assembly shall be constructed of precision cast high strength aluminum alloy. It shall feature a cast-in-place guide that mate with the fixed portion of the *Disconnect Unit* to aid in tracking and stability. All hardware used on the *Lower Contact Assembly* as well as the entire *Disconnect Unit* shall be made of corrosion resistant stainless steel.

❖ The disconnect unit shall have a **HOUSING SEAL** made up of a spun aluminum closure ring with a sealing gasket constructed of extra flexible polymer providing a weather-tight seal between *Lower Contact Assembly* and *Disconnect*

Unit Cover. This provides a flexible environmental seal. Seal swipes and conforms to interior of cylinder housing during all operating stages of the disconnect unit.

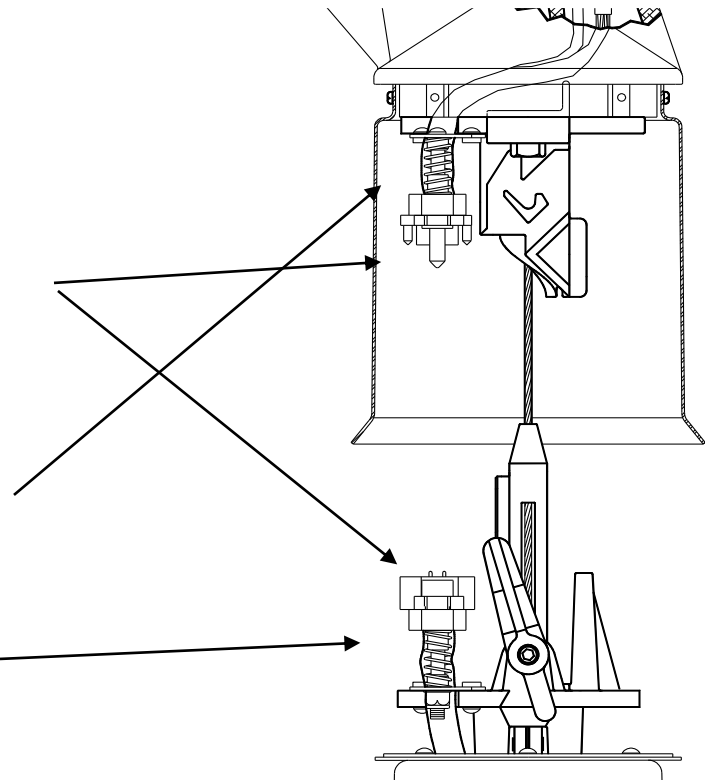

Electrical Contact Rating: 35 Amps at 600 volts per contact. (2 circuit standard, optional up to 4 circuits)

Mechanical Rating: 400 lbs with 6:1 safety factor

Weight: 8.5 LBS

SYSTEM DESIGNED SPECIFICALLY FOR USE WITH LIGHT FIXTURES, CAMERAS, AND RELATED EQUIPMENT ONLY.
NOT FOR LIFTING PEOPLE OR THINGS OVER PEOPLE.
SPECIFICATIONS SUBJECT TO CHANGE WITHOUT NOTICE.

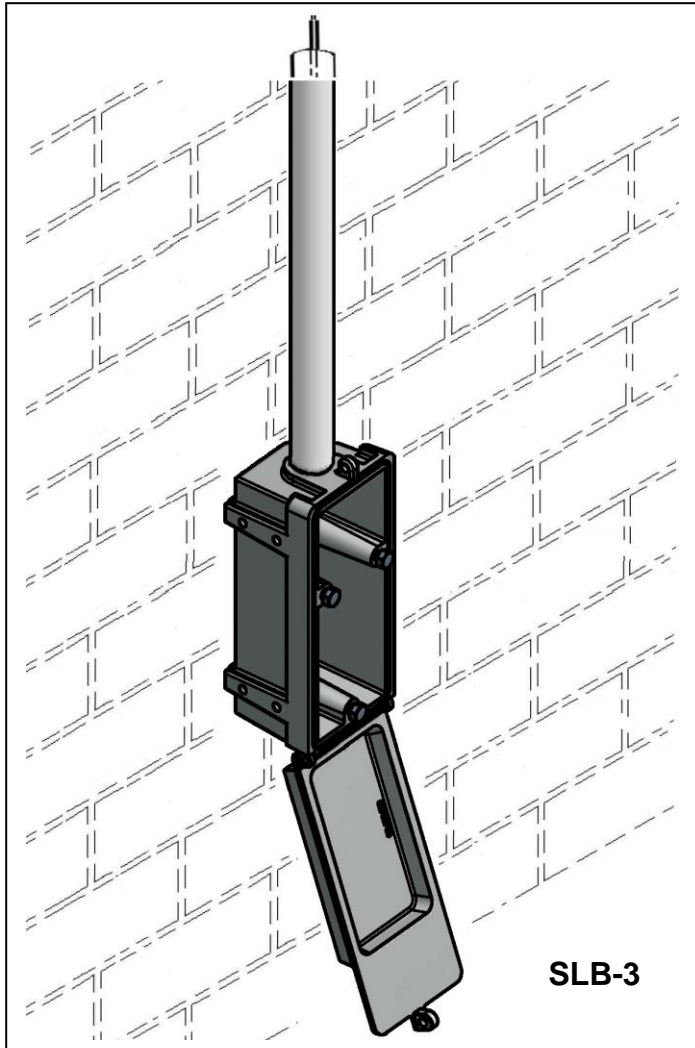

Security Locking Box Design SLB-3

Each lowering cable must be terminated in a locking system. Two types are available to prevent unauthorized personnel from lowering the fixtures. The ECS system utilizes the **SLB-3** security locking box.

To mount and use the box:

- The box can be mounted to the structure in the back of the box or the side of the box. There are dimples in the back of the box to guide where the holes should be drilled.
- Always mount the box to a structure that will not pull out. Always assume 600 lbs of weight being placed on the box when the fixture is being raised and lowered.
- **SECURITY:** When conduit entry is required and maximum protection is required, the use of the **SLB-3** security locking box is required. The box is of heavy gauge aluminum. Attach 1 ½" conduit to the top of the box. The fixture cable will be riding inside the conduit.
- An Eye Bolt is attached to the inside of the Lock Box to be used as a "Parking Stand" for the cable. Always attach the fixture cable to the Eye Bolt when the fixture is not being raised or lowered for safety.
- **CORROSION RESISTANCE:** The cast aluminum box prevents corrosion. For highly corrosive areas, an optional painted unit is available.
- Vandal proof construction uses non-tool hardware.
- Hinged door utilizes tool-less hardware, preventing breaking into the box. The cover can be locked to the box using the lock opening on the top of the cover.
- Neoprene gasket around the door opening prevents water from penetrating.
- The lowering tool to service this box is the **LT-4-XX** (order separately). Each locking box uses a **CCS-1** cable attachment for use with conduit. The **CCS-1** is small enough for the conduit, but strong enough to handle up to 400 lbs fixtures. Recommended conduit size should be 1 ½".

BOX DIMENSIONS: 14"High x 6"Wide x 5"Deep

All gear boxes and lowering tools are of heavy duty design to provide reliability, long life, and ease of operation.

TO OPERATE LT-4-XX:

- A. Unlock cover of Security Lock Box and gently lower cover down.
- B. Attach frame of the **LT-4-XX** to the Security Lock Box with the 3 bolts provided. Tighten securely.
- C. Release enough cable from the winch in order to attach to the fixture cable.
- D. Attach connecting link from the Lowering tool cable to the fixture cable.
- E. Detach fixture lowering cable from the secure eye bolt in the Security Lock Box **AFTER** the fixture cable is connected to the Lowering Tool cable, for safety reasons.
- F. Do not stand underneath the fixture while it is being lowered. With the handle of the lowering tool, turn the handle to pick up the slack from the cable. When the cable gets tight, continue cranking about 3/4 to 1". **DO NOT OVER CRANK THE CABLE, OR DAMAGE MAY OCCUR TO THE CABLE.**
- G. When the cable is tight, the cable connecting link should not be riding over the pulley sheave (wheel) or into the winch cable drum. If it is, trim off extra fixture cable on the Disconnect Unit end of the fixture cable.
- H. Reverse direction of the handle and lower the fixture. The fixture should now be disconnected from the lock position and being lowered. Make sure no one is standing underneath the fixture while being lowered.
- I. If the fixture does not lower, repeat operation **F - H**.
- J. When the fixture is raised and locked in place, there should be slack on the cable.
- K. Connect the fixture lowering cable to the Eye Bolt in the Security Lock Box before disconnecting the Lowering Tool cable from the fixture cable.
- L. Crank the winch to pick up the extra slack on the winch cable. Too much cable slack on the winch will cause the cable to tangle on the winch drum.

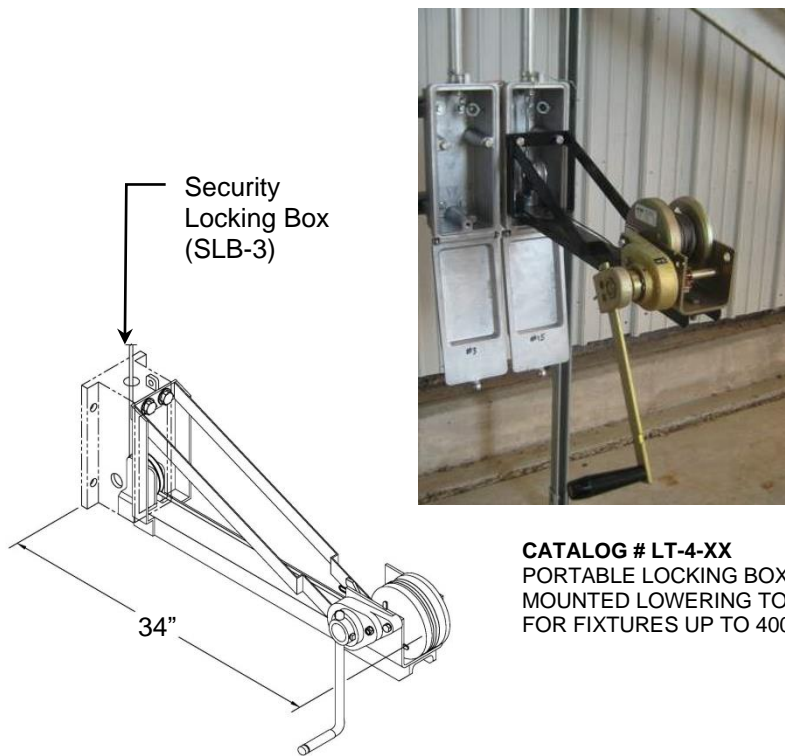

CATALOG # LT-4-XX
PORTABLE LOCKING BOX
MOUNTED LOWERING TOOL
FOR FIXTURES UP TO 400 LBS.

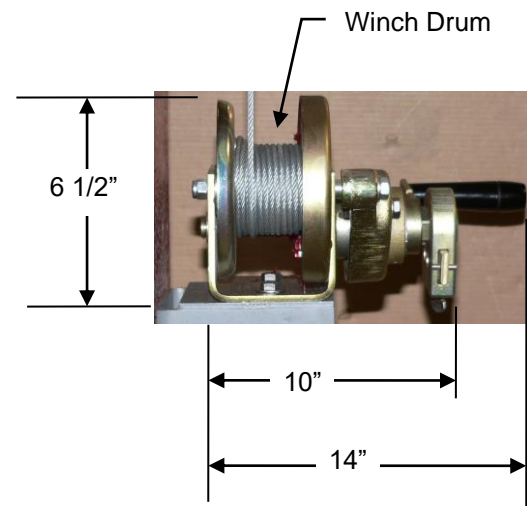

PREVENTATIVE MAINTENANCE

Upon installation of the system, periodic preventive maintenance should be done to the system. The following is a list of preventative maintenance operations and schedule:

LOWERING TOOL

1. The tool should be kept in a clean and dry area.
2. During every usage of the Lowering Tool, the raising and lowering cable should be checked for kinks, cut strands, and any irregularities, each time the tool is used.
3. The gears on the winch should be checked for gearing grease. If the gear box looks dry, gear grease should be applied on the gears only, with a small paint brush. The grease should be applied liberally covering all gears. Recommended grease should be **UNIWRI 2 product #C163520** Manufactured by: **Fuchs Lubricants**. (PH: 800-800-OILS) This grease can be obtained through Camera Lowering Systems.
4. A drop of **10W-30 oil** should be applied in opening of casement (see sign on winch). Only apply one drop annually. After applying, crank the winch at least 3 revolutions to distribute the oil.
5. Check the cable for any kinks, bends, or stray cut wires. This will tell you if cable is rubbing on an obstruction. If cable is damaged, it will weaken the cable, possibly causing the cable to break. Damaged cables should be replaced. See attached "cable handling" page. Handle wire rope with gloves to avoid possible hand cuts caused by stray wires.

DISCONNECT UNIT

1. Each time the disconnect unit is lowered, check the condition of the system. If there are any signs of irregularities, contact the factory.
2. Keep the guide pin and "rest button" on the locking cams cleaned and well lubricated with: **'Super Lube multipurpose grease with Syncolon, manufactured by SYNCO CHEMICAL CORP'** or equivalent.
3. The locking cams should be checked each time the camera is lowered. Ensure that the shoulder screw is tightened.
4. Check all screws, nuts and fastenings are tight.
5. Check composite cable for any irregularities.