



Installation Manual	
Part No.	Description
CEPM Series	Pole & Tower External Mount Systems

BY DONALD PIKE	REVISION A	DATE 8 28 23
-------------------	---------------	-----------------

# Installation & Operation Manual

## Camera External Pole Mount (CEPM) Camera Tower Mount

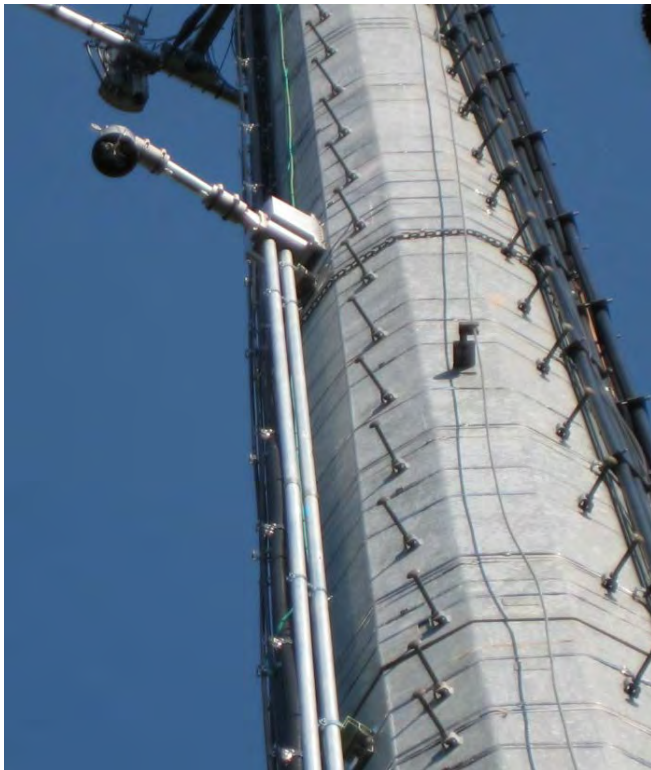

### SAFETY WARNING

Please follow all state and local safety regulations while you are performing this work. Regarding and understanding this manual will significantly reduce the risk of injury.



## Table of Contents

Table of Contents.....	ii
Purpose of This Manual.....	1
Company Description.....	2
Composite Cable Handling.....	3
Chapter 1 Installation.....	4
1.1 Mounting the Arm Assembly to the Top Box.....	5
1.2 Leveling the Arm.....	6
1.3 Cable clamp assembly.....	7
Chapter 2 Unit Guide Cable.....	8
Chapter 3 Conduit Installation.....	9
Chapter 4 Lowering Cable Termination-SLB-3.....	10
CEPM Installation Guide.....	11
Camera Junction Box Installation.....	12, 13
LT-4-SSXX Lowering Tool.....	14
Chapter 5 Frequently Asked Questions.....	16
Cable Handling Instructions.....	17
Maintenance.....	18

-  
**NOTE: THE INSTALLER MUST PROVIDE THE 1.5" CONDUIT, PVC SOLVENT CEMENT (IF PVC), FITTINGS, AND STANDOFF BRACKETS TO ATTACH THE CONDUIT TO THE TOWER OR POLE.**  
 -



## Purpose of This Manual

At Lighting & Lowering Systems and Camera Lowering Systems, products are designed to make installation easy and operation uncomplicated. The product will give outstanding service when properly installed according to the instructions and operated according to the guidelines provided in this manual.

The purpose of this manual is to serve as a “road-map” for the user to the installation, and operation of the Aeronautical Lowering System. In addition to that, the purpose of this manual is also to guide the user in cases of emergency and operation of the system.

Please take utmost care in installing the system. It is very important that all units are mounted on rigid supports and level surfaces and the installation is approved by others. It is also very important to read all the instructions before installing, programming and operating the system.

If you have any questions or suggestions, please contact us at [donpike@nslights.com](mailto:donpike@nslights.com)

### **WARNING**

- **EXCEPT WHEN TESTING, PROGRAMMING AND OPERATION, NEVER LEAVE THE SYSTEM IN ANY OTHER THAN LOCKED POSITION.**
- **DO NOT LEAVE THE SYSTEM UNATTENDED WHEN NOT IN LOCKED POSITION.**
- **DO NOT LIFT PEOPLE OR OPERATE ANY LOWERING SYSTEM OVER PEOPLE.**



## Company Description: North Star Lighting, LLC

Though it's easy to tell North Star's product story, we prefer to let our customers speak for our ability to deliver outstanding results. What is important here is North Star's long standing reputation for providing a comprehensive, highly energy efficient family of LED, HID (high intensity discharge), and Lowering Systems, meeting our customer's precise performance and price requirements for Lighting Systems and Lowering Systems, which include Sports lighting, Commercial lighting, Architectural lighting and for Lowering Systems for Cameras, Lights, Speakers, Gas detectors, etc.

### Lighting & Lowering Systems ♦ Camera Lowering Systems

Lowering Systems, a product line of North Star Lighting, LLC, has experience in lowering systems dating back to 1967. Our engineering and marketing know how has been a major force in the industry starting with our pioneering efforts in the development of the first raising and lowering High Mast system in the United States.

Realizing the need for this type of maintenance we have perfected new lowering systems for indoor and outdoor applications at reduced cost; at the same time keeping the system simple and safer for maintenance people to operate.

Lowering devices offer three major features

- Safety
- Simplicity
- Value

New lowering systems offer fast, safe and easy maintenance of cameras and other devices in high or inaccessible areas. All servicing is done at ground level. Hazardous and time consuming high lift truck maintenance is eliminated. The efficiency of the higher mounting height need not present a problem in servicing the equipment. The use of high mounting height results in fewer cameras. This in turn results in reduced installation costs and less power usage. This savings offsets the cost of the lowering system. Cameras and other devices are lowered individually eliminating the need to lower massive lowering units which are complicated, expensive and heavy.

## COMPOSITE CABLE HANDLING RIGHT and WRONG



The composite cable assembly consists of the coaxial cable, electrical power cables, twisted pair, and/or ethernet signal cable.

The composite cable is very delicate because of the signal carrying properties and should be handled with care.

There is a correct way to handle the composite cable assembly and a wrong way.

**DO NOT** carry the CDP assembly by the cable. Pressure can be placed on the cable, causing damage, possible breakage of wires. Also, the cable might pull off or partially off the crimped contact connector.

**ALWAYS** carry the CDP assembly as shown on the left. Take the pressure off the cable by putting the roll over the shoulder.

The CDP should be carried with both hands carrying the arm assembly as shown.

## Chapter

## 1

# Installation

The CEPM/CTMT Mount Lowering System is designed to make installation and set-up as straightforward as possible and will provide excellent service when properly installed in accordance with the following instructions.

**IMPORTANT**

**The lowering cable should not touch or interfere with any obstructions during the system operation.**

Figure 1.1.1 mounting details

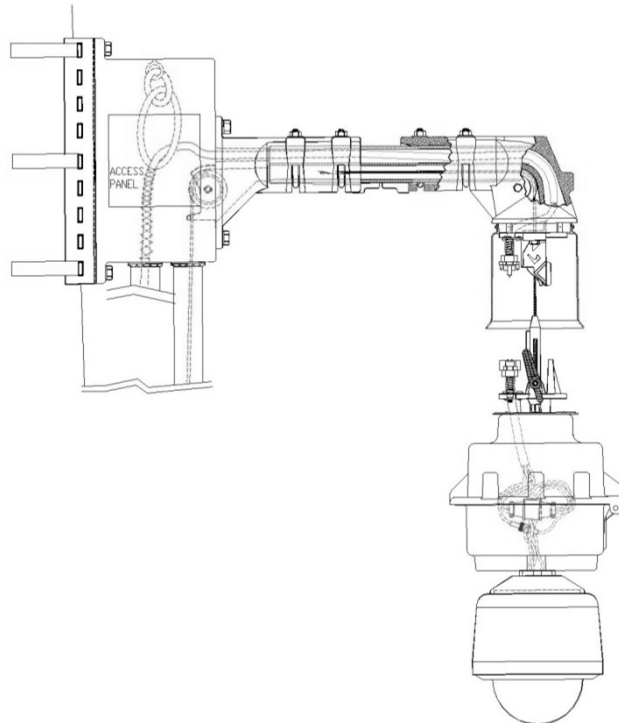

## 1.1 Mounting the Arm Assembly to the Top Box

1. Remove all items from the crates and make sure all components were shipped and not damaged.
2. Place components on a clean working surface so as not to damage or dirty the units.
3. Remove the Access Panel from the side of the mounting box.
4. Properly unwind the composite (elect/signal) cable and feed it thru the rectangular opening in the front of the box. Feed the composite cable thru the top of the 1 1/2" conduit opening in the top of the box, or thru the opening in the bottom of the box closest to the pole or tower.
5. Properly unwind the raising and lowering stainless steel cable and feed it thru the rectangular opening in the front of the box and into the 1 1/2" conduit opening on the bottom closest to the arm assembly (see drawing).
6. Mount the arm to the front of the box with the two stainless steel 1/2"-13 bolts and washers.
7. Adjust the composite cable and attach the strain relief into the eye-bolt inside the box. Be sure there is slack in the composite cable going into the arm.
8. Once completed, re-attach the Access Panel onto the side of the mounting box.

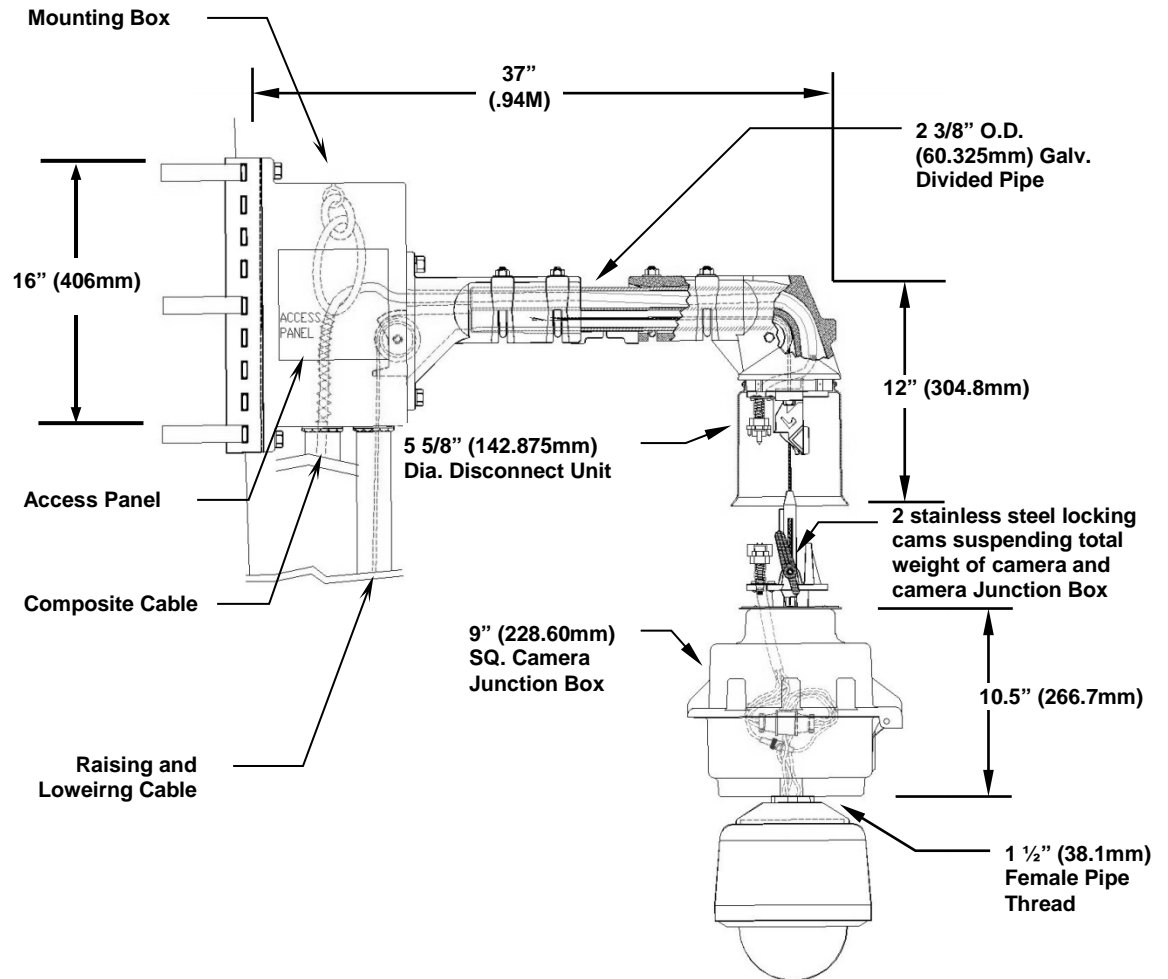



# INTERLOCKING ARM & FITTERS

PROVIDES POSITIVE NON-ROTATING POSITIONING OF PIPE ARM FOR ALL OUTDOOR POLE AND WALL MOUNTED LOWERING SYSTEMS

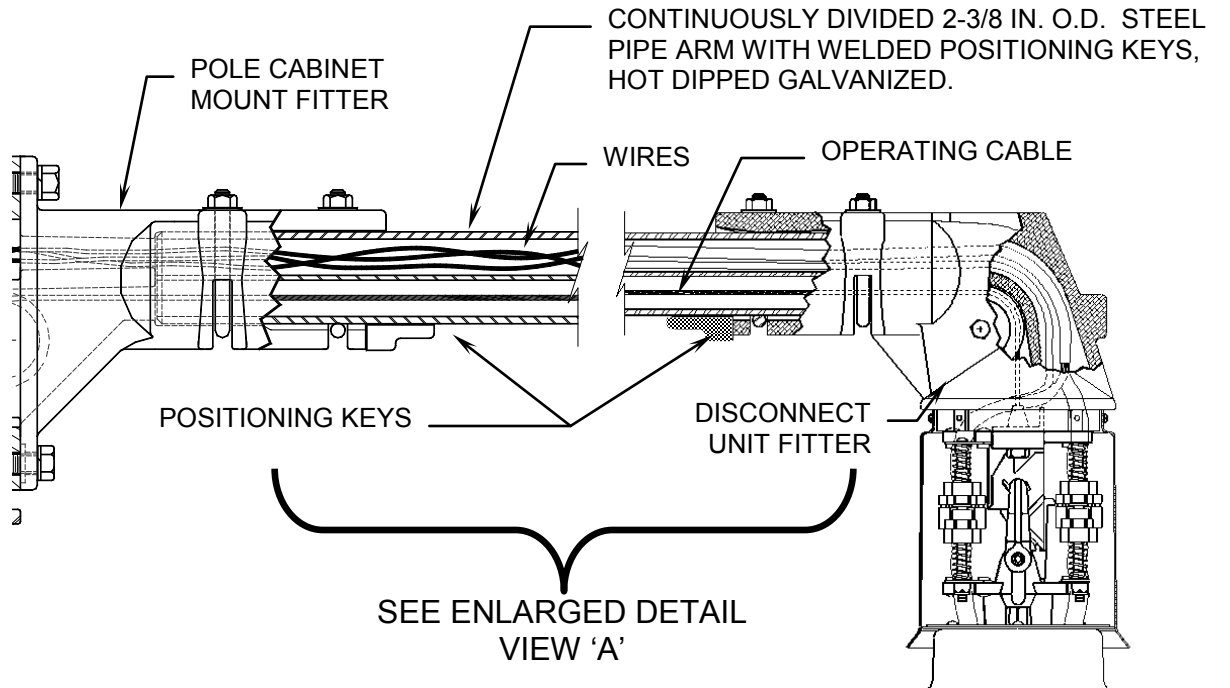

## FEATURES

Specially shaped steel keys are welded to divided pipe arm before arm is galvanized. Precise alignment of keys with corresponding notches in the pole/wall fitter and the disconnect unit fitter provide positive positioning and prevents rotating of components about the divided pipe arm during extreme environmental conditions.

Pipe arm has full length divider separating the wires from the movement of the control cable. Separate chambers within the fitters for electrical wires and the control cable assures complete protection to the wires during the operation of the system.

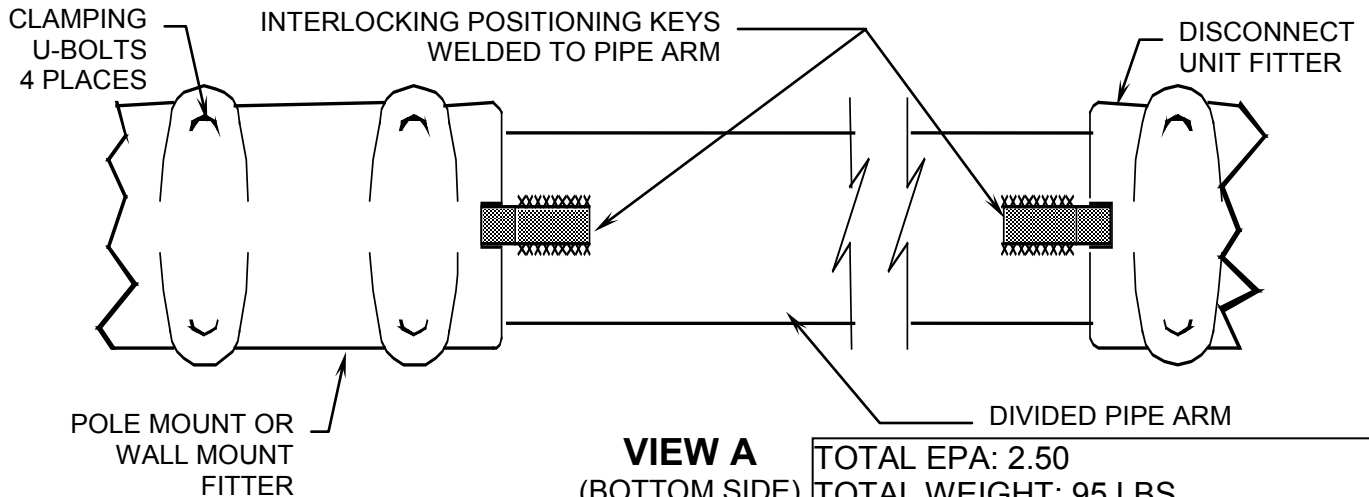
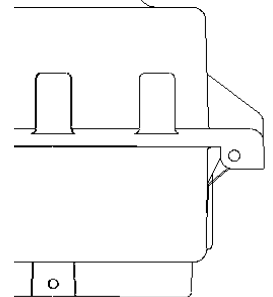

**VIEW A**  
(BOTTOM SIDE)

TOTAL EPA: 2.50  
TOTAL WEIGHT: 95 LBS  
(includes arm, disconnect unit, camera junction boxes, & camera)



## 1.3 Cable Clamp Assembly

### **WARNING**

**To prevent serious personal injury, the cable clamp must be properly assembled and the cable must be properly routed through the clamp as specified within. No attempt at lifting any load should be made until all specification conditions are met. Use only the cable provided by Lighting & Lowering Systems with this clamp.**

### 1.3.1 Fixing Cable in the Clamp

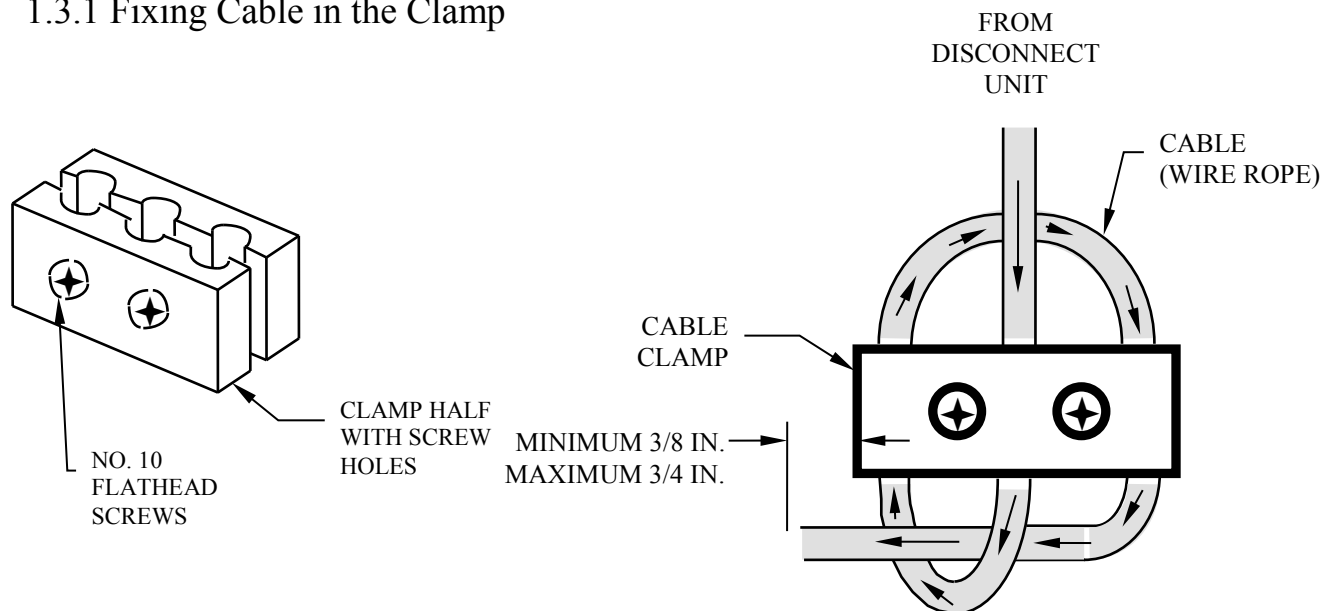

**Figure 1.3.1 Cable Clamp Assembly.**

To facilitate ease of feeding the wire through the cable clamp, trim leading end of cable square making sure there are no protruding strands of wire. **Do Not Use Lubricant Of Any Kind On The Portion Of Cable that Is To Be Within The Cable Clamp.**

1. Loosen screws of clamp to separate the clamp halves enough to fit the cable through the notches but do not remove the screws completely.
2. Feed cable end coming from the bottom of the disconnect unit into the center notches of the cable clamp. Pull approximately 5 inches of cable through the clamp.
3. Insert the end of the cable through one of the side notches. Cable should move easily through the notches of the clamp. If the cable is too loose and moves out of the notches, tighten the screws slightly until the cable stays within the notches. Do not pull cable tight.
4. Pass the end of the cable across to the other side notch and through the clamp.
5. End of cable must be fed through loop formed by cable coming from center notch and first side notch so that when cable is pulled tight the loop closes on the end portion of the cable.
6. Carefully pull the cable loops tight by back pulling on the cable portion coming from the disconnect unit. Be sure cable remains within the notches of the clamp. With all loops small as possible, tighten no. 10 screws in an alternating pattern until tight. End of cable should extend approximately 3/8 to 3/4 inch past edge of cable clamp. Trim cable end as required.
7. Check cable clamp, cable, and screws for tightness every time cable clamp is lowered when the system is operated.



# Unit Guide Cable

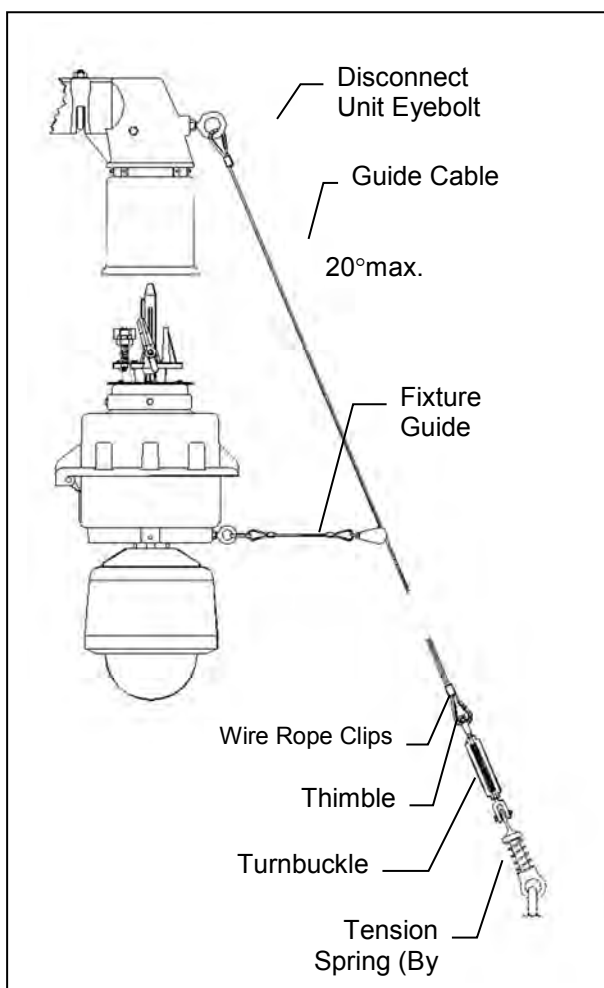

- 1) Attach Tension Spring (By Others, One per fixture assembly) about 20° Max from camera.
- 2) Attach Guide Cable Quick Link to Eyebolt on Disconnect Unit.
- 3) On other end of cable, slip through pulley on Camera Guide.
- 4) Attach Turnbuckle to Tension Spring.
- 5) Attach Thimble to Turnbuckle.
- 6) Slip Guide Cable around Thimble and bring short end of cable next to long end of cable.

- 7) Install U-bolt section of Wire Rope Clip on short end of rope, and saddle on long end of rope and tighten nuts evenly.
- 8) Apply first clip as near the thimble as possible.
- 9) Apply second clip about one inch away from first clip.
- 10) Tape cable with electrical tape and cut extra cable in center of tape.
- 11) On short end of cable, leave about one inch of cable from cable end to second clip.

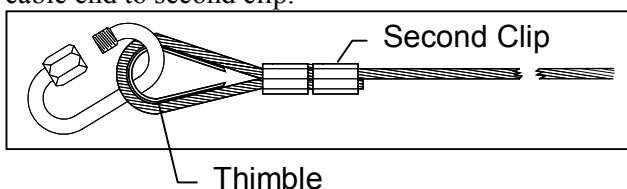

- 12) A tension spring should be provided in each guide cable to provide sufficient tension to hold guide cable taut (30-50 lbs) depending on length of guide cable. It must provide also sufficient movement for the sway of the structure (tower, stack, pole, wall) under maximum wind load without exerting more than 150 lbs. tension on the guide cable. The brackets must be properly anchored and secured to withstand this load. Tension spring is not required if sway at top of structure is less than 6°, under maximum allowable wind load.
- 13) Attach rope to the disconnect unit flange after mounting the arm to the tower.



# Conduit Installation

## Chapter

# 3

There are several different ways to install the conduit.

- 1) We require that the conduit for the raising and lowering system be mounted in line with the pulley in the wall mounted fitter down to the Security Locking Box or winch box at the base of the tower/pole. The alignment is to ensure that the lowering cable does not rub against the conduit or conduit fittings inside the conduit.
- 2) Larger conduit sizes, helps ensure this from happening. A 1½" conduit should be the minimum size conduit for the lowering cable.
- 3) If there are any bends in the tower caused by different taper in the tower, a pulley or roller must be added to allow the cable to roll without rubbing.



- 4) The conduit should be attached to the tower in such a manner that the conduit will not move.
- 5) The communication/power cable should be attached to a strain relief at the top, and should come down the pole in a separate conduit than the lowering cable. The communication cable should terminate in the electrical cabinet.
- 6) Cable clamps as seen in these photos must be used approximately every 8 feet.

# Lowering Cable Termination-SLB3

## Chapter

# 4



- 1) The conduit for the lowering cable must terminate in the Security Lock Box.
- 2) The Security Lock Box must be secured firmly to the mounting structure at about 3ft from ground level. The box can be mounted at a different height if need be. Stainless steel bands are a preferred way of attaching the box to the structure.
- 3) The lowering cable must be attached to the eyebolt in the Security Lock Box when not in use.
- 4) The camera lowering cable length can now be cut to the proper length (see page 5).
- 5) The LT-4 portable lowering tool is inserted into the box utilizing the 3 bolts provide with the box.
- 6) Before lowering the cable, attach the cable to the camera cable with the quick link provided.
- 7) Then detach the camera cable from the eyebolt.

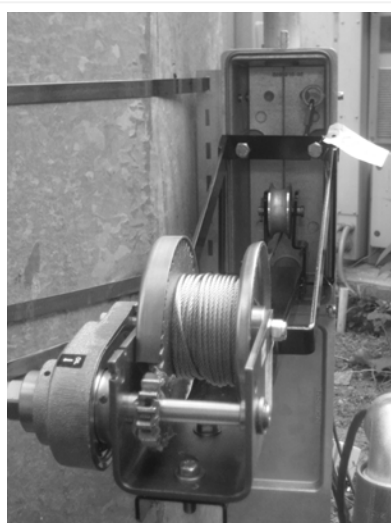

LT-4 lowering tool is attached to the lock box utilizing the 3 bolts.



Lowering cable from the camera is attached to the eyebolt in the security lock box at the base.



Cable from the LT-4 is attached to the camera lowering cable. Then the camera cable is disconnected from the eyebolt (cable parking stand).





## Installation Instructions

1. While assembly is on the ground, run a continuity check on all wires.
2. Mount Arm box to the tower.
3. Provide and mount a junction to the arm box.
4. Provide a cable strain relief for the composite and mount it to the junction box.
5. Attach conduit to base of arm box all the way to base of tower for the raising and lowering cable. Cable must run in line from pulley in arm to base of tower without any turns. Make sure conduit is large enough so that cable does not rub against edge of conduit (1" conduit or larger). Hole in box may have to be redrilled to match conduit.
6. Provide standoff support for conduit attached to tower approximately every 10 feet.
7. Provide and attach conduit (1" conduit or larger) for the signal cable. Conduit should be attached to junction box.
8. Provide standoff support for conduit attached to tower approximately every 10 feet.
9. Prepare the arm to mount to the box. **DO NOT** allow composite cable to free hang. The weight of the composite cable free hanging could cause damage to the cable, especially the coax.
10. Never grab arm assembly by the composite cable, allowing the weight of the arm to hang from the composite cable. Lift arm and composite cable evenly and at the same time, so as not to put any stress on the composite cable.
11. Before attaching the arm to the mounting box, fish the raising and lowering cable through the arm box and into the conduit for the lowering cable.
12. Then, fish the communication cable through the arm box and feed it into the junction box.
13. Attach the strain relief on the cable and fish through the communication cable conduit.
14. Make sure there is a little slack on the communication cable between the arm and the strain relief.
15. Then attach the arm assembly to the mounting box.
16. Level arm assembly as needed by loosening mounting bolts and u-bolts as needed. Tighten down hardware after assembly is level from side to side and up and down.
17. Lowering cable should be fed down conduit for lowering cable.
18. Attach a rope (or cable tie-off) to bottom of disconnect unit while it is in the locked position.
19. Attach the lowering cable to the winch cable at the base.
20. Manually crank winch to raise unit to unlock. **DO NOT OVERCRANK**. To unlock, the slack in the cable is taken up, then the unit only raises  $\frac{3}{4}$ ".
21. Reverse direction and lower the movable portion of the disconnect unit.
22. Pull on the rope to get it unattached.
23. After lowering the bottom half of the disconnect unit, attach the Camera Junction Box to bottom of disconnect unit with 4 bolts provided. Careful in feeding the communication cable through the inside of box.
24. Disconnect rope from bottom of disconnect unit and attach to junction box.
25. Raise and lock and unlock unit several times to make sure unit is installed properly and is level. Pull on rope if needed while working on unit. When the unit is locking and unlocking and lowering properly, remove the rope.
26. Have a continuity test on electrical wires after installation.
27. Mount camera to camera junction box and connect wires inside box.
28. Raise camera to locked position and check for power and communication. Lower and raise unit to insure unit is working properly.

## ATTACHING THE CAMERA JUNCTION BOX

01. Lower the moveable portion of the disconnect unit down to working condition within 4ft from the ground.

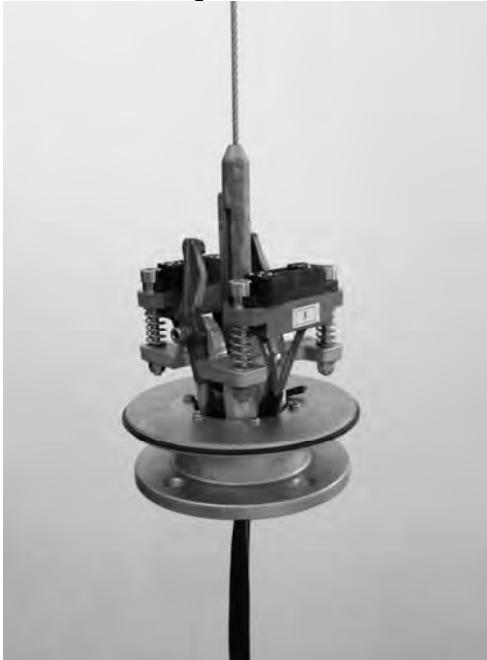

02. Unhinge the two clam shells of the Camera Junction box from each other.

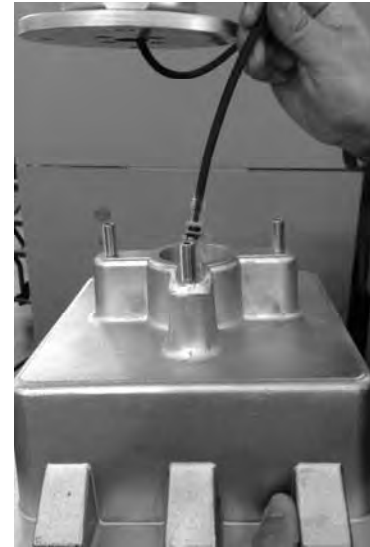

03. Put the communication cable from the lower half of the disconnect unit thru the opening of the upper half of the Camera Junction Box.

04. Align the four 3/8" threaded rods of the Camera Junction Box with the mounting flange of the lowered disconnect unit.

05. Attach washers and nuts provided, onto the threaded rod. After two nuts have been partially threaded onto the rods, it is not necessary to hold the upper half of the junction box.



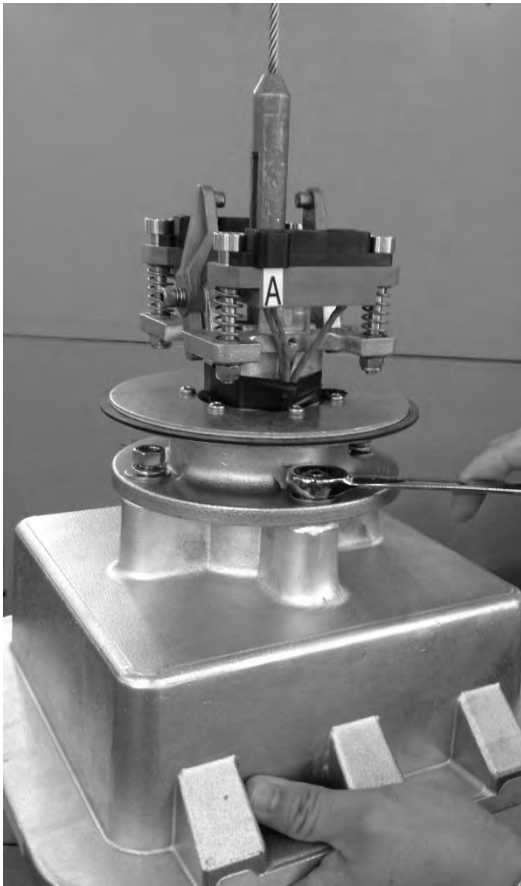

06. Attach the rest of the hardware onto the rods and tighten.
07. Attach the bottom half of the junction box to the upper half with the 2 hinges.
08. Insert the communication wires into the box, and other hardware.



09. Close the box utilizing the stainless steel lock by turning the lock until it stops.
10. The box is now attached.
11. Check the center guide pin and make sure that it is well lubricated. It should come from the factory lubricated.
12. The Camera Junction Box has weights inside the box to allow the system to be lowered.
13. Raise the unit to the top. The drill can be used at this time. The drill should not be used during the operation of the last 1-2 feet. Manually raise the unit to the top.
14. Then reverse direction and lower the unit until there is slack in the cable.
15. Repeat the lowering and raising operations several times to make sure the system is operating properly.
16. If the camera is available, connect the camera to the junction box when lowered, and connect the signal/power cable.

#### **ADDITIONAL NOTES**

Make sure that the pole and the arm assembly is level. The system will not work if the disconnect unit is not level.

Never operate the system over people. For safety precautions, people should stay clear of the assembly during the raising and lowering operation.





# LT-4-XX LOCKING BOX LOWERING TOOL

## INSTRUCTION GUIDE FOR USAGE OF PRODUCT

All gear boxes and lowering tools are of heavy duty design to provide reliability, long life, and ease of operation.

### TO OPERATE LT-4-XX:

- A. Unlock cover of Security Lock Box and gently lower cover down.
- B. Attach frame of the **LT-4-XX** to the Security Lock Box with the 3 bolts provided. Tighten securely.
- C. Release enough cable from the winch in order to attach to the fixture cable.
- D. Attach connecting link from the Lowering tool cable to the fixture cable.
- E. Detach fixture lowering cable from the secure eye bolt in the Security Lock Box **AFTER** the fixture cable is connected to the Lowering Tool cable, for safety reasons.
- F. Do not stand underneath the fixture while it is being lowered. With the handle of the lowering tool, turn the handle to pick up the slack from the cable. When the cable gets tight, continue cranking about 3/4 to 1". **DO NOT OVER CRANK THE CABLE, OR DAMAGE MAY OCCUR TO THE CABLE.**
- G. When the cable is tight, the cable connecting link should not be riding over the pulley sheave (wheel) or into the winch cable drum. If it is, trim off extra fixture cable on the Disconnect Unit end of the fixture cable.
- H. Reverse direction of the handle and lower the fixture. The fixture should now be disconnected from the lock position and being lowered. Make sure no one is standing underneath the fixture while being lowered.
- I. If the fixture does not lower, repeat operation **F - H**.
- J. When the fixture is raised and locked in place, there should be slack on the cable.
- K. Connect the fixture lowering cable to the Eye Bolt in the Security Lock Box before disconnecting the Lowering Tool cable from the fixture cable.
- L. Crank the winch to pick up the extra slack on the winch cable. Too much cable slack on the winch will cause the cable to tangle on the winch drum.

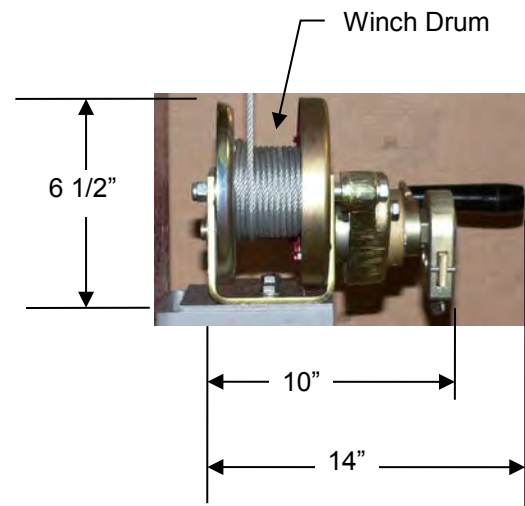
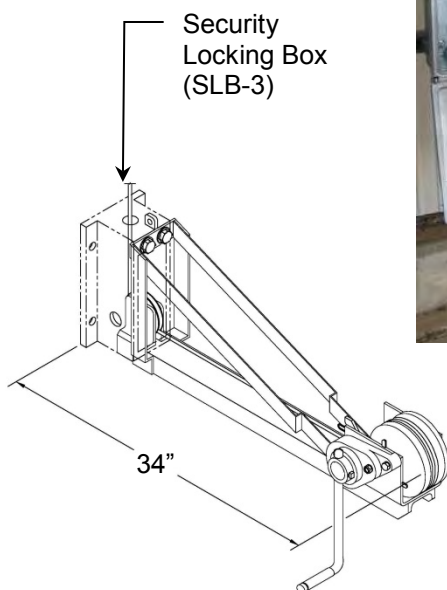

**CATALOG # LT-4-XX**  
PORTABLE LOCKING BOX  
MOUNTED LOWERING TOOL  
FOR FIXTURES UP TO 400 LBS.

# Frequently Asked Questions

## Chapter

# 5

### Problem:

### Reasons and/or solutions:

1) No communication or power to the camera

- a) Input power may not be on.
- b) Wire connections may be improper.

2) The disconnect unit will not unlock

- a) Camera may not be heavy enough. (The camera and CAMJB must weigh at least 40 LBS).
- b) Follow the procedure for locking the system again and then try to unlock.
- c) Disconnect unit may not be level.

3) Lowering cable is tangled on the winch drum

- a) With the fixture in the locked position, unwind the cable from the drum.
- b) Put tension on the cable by pulling on it, and wind the cable back on the drum evenly.
- c) Always use protective gloves before touching cable to prevent loose metal strands from piercing the skin. It is important to keep gloves away from the gears.
- d) Allow the cable to wind back and forth on the drum smoothly.
- e) Do not allow cable to get tangled on the drum.

7) The system will not lock

- a) The disconnect unit may not be level.
- b) The arm or the pole may not be level.

For additional questions, call factory at 708-681-4330 and ask for a Camera Lowering System technician for assistance. Technician can also be reached at [Sales@nslights.com](mailto:Sales@nslights.com).



**1. Uncoiling – RIGHT METHOD**

Place the coil on a swift or turntable, cut the tie-bands and pull the outer end of the rope away in a straight line, allowing the swift or turntable to rotate. (See Fig. 1).

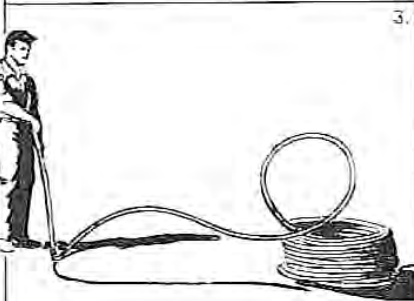

**2. Uncoiling – RIGHT METHOD**

Cut and remove the tie-bands and roll the coil along the ground leaving the rope lying straight on the ground.

**3. Uncoiling – WRONG METHOD**

**4. Uncoiling – WRONG METHOD**

Do not uncoil as shown in figs. 3 or 4 by placing the coil on the ground and pulling either the outside or inside ends of the rope away. The illustrations show the results. Kinks will be formed and the rope may be ruined. (See figs. 9, 10, and 11).

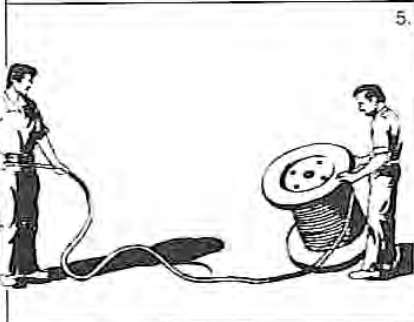

**5. Unreeing – WRONG METHOD**

Do not tilt the reel and “lap-off” the rope from the top side as shown in fig. 8. Kinks will be formed.

**6. Unreeing – RIGHT METHOD**

Put a shaft through the reel and jack up both ends to allow it to rotate freely. Pull the free end of the rope away in a straight line as shown in fig. 6.

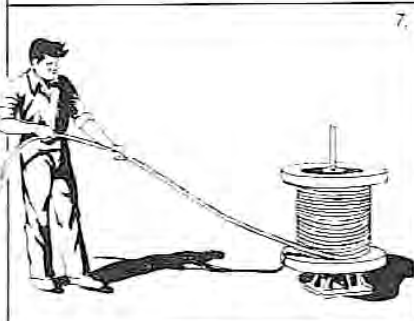

**7. Place** the reel on its side on a vertical spindle and pull the free end of the rope in a straight line as the wheel rotates.

**KINKS**

A kink is caused by the rope taking a spiral set due to unnatural twist in the rope and is probably most frequently caused by faulty coiling and unreeing.

**8.** This shows the first stage of a kink. At this point, it can still be corrected and damage to the rope prevented by throwing out the loop.

**9.** This shows the result after the kink has been pulled through. The rope is now permanently damaged.

**10.** This shows the final result after the rope has been straightened. The wires and strands are permanently misplaced and the relative balance between individual wires and strands has been disturbed. No matter how slight the damage may appear from a superficial examination, the rope has been distorted and can never give the maximum life.

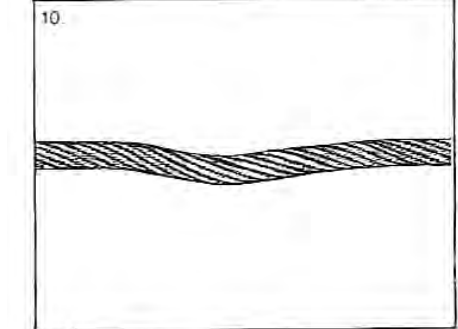
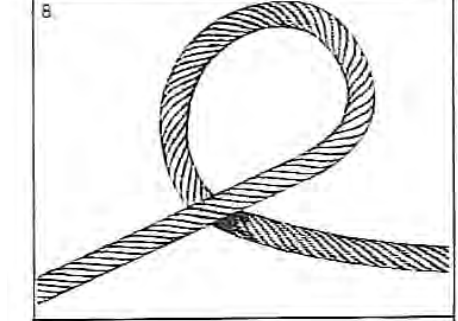
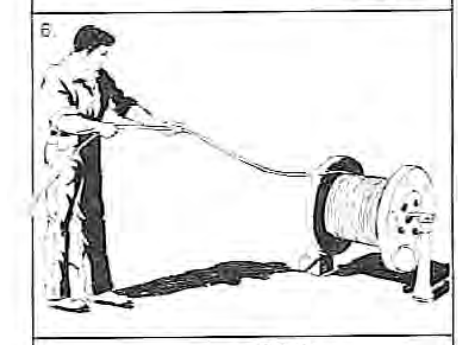

# MANUAL SYSTEMS PREVENTATIVE MAINTENANCE

Although the system requires minimal maintenance, after installation of the system, periodic preventive maintenance should be done to the system. The following is a list of preventative maintenance operations and schedule:

## LOWERING TOOL

1. The tool should be kept in a clean and dry area.
2. During every usage of the Lowering Tool (LT-CC, GB-2P, LT-4, Permanent Tool), the raising and lowering cable should be checked for kinks, cut strands, and any irregularities, each time the tool is used. Do not run cable thru bare hands, as the cable strands may cut your hand.
3. The gears on the winch should be checked for gearing grease. If the gear box looks dry, gear grease should be applied on the gears only with a small paint brush. The grease should be applied liberally covering all gears. Recommended grease should be UNIWRI 2 product #C163520 Manufactured by: Fuchs Lubricants (PH: 800-800-OILS) or other all temperature gear grease. This grease can be obtained through Camera Lowering Systems.
4. A drop of 10W-30 oil should be applied in opening of casement (see sign on winch). Only apply one drop annually. After applying, crank the winch at least 3 revolutions to distribute the oil.
5. Check the steel lowering cable for any kinks, bends, or stray cut wires. This will tell you if cable is rubbing on an obstruction. If cable is damaged, it will weaken the cable, possibly causing the cable to break. Damaged cables should be replaced. See attached "cable handling" page. Handle wire rope with gloves to avoid possible hand cuts caused by stray wires.

## DISCONNECT UNIT

1. Every time the disconnect unit is lowered, check the condition of the system. If there are any signs of irregularities, contact the factory.
2. Keep the guide pin and "rest button" on the locking cams, cleaned and well lubricated with: 'Super Lube multipurpose grease with Syncolon, manufactured by SYNCO CHEMICAL CORP' or equivalent .
3. The locking cams should be checked every time the camera is lowered. Ensure that the shoulder screw is tightened.
4. Check all screws, nuts and fastenings and make sure they are tight.
5. Check signal cable and steel cable for any irregularities.
6. The Camera Junction Box should be bolted to the disconnect unit using the four (4) ¼-20 Hex bolts with lockwashers provided by CLS. Torque Ratings: Torque rating on all ¼" bolts should be 20-25 LBXFT.