

## ELECTRONIC CONTROL MODULE FOR MULTIPLE LOWERING SYSTEMS

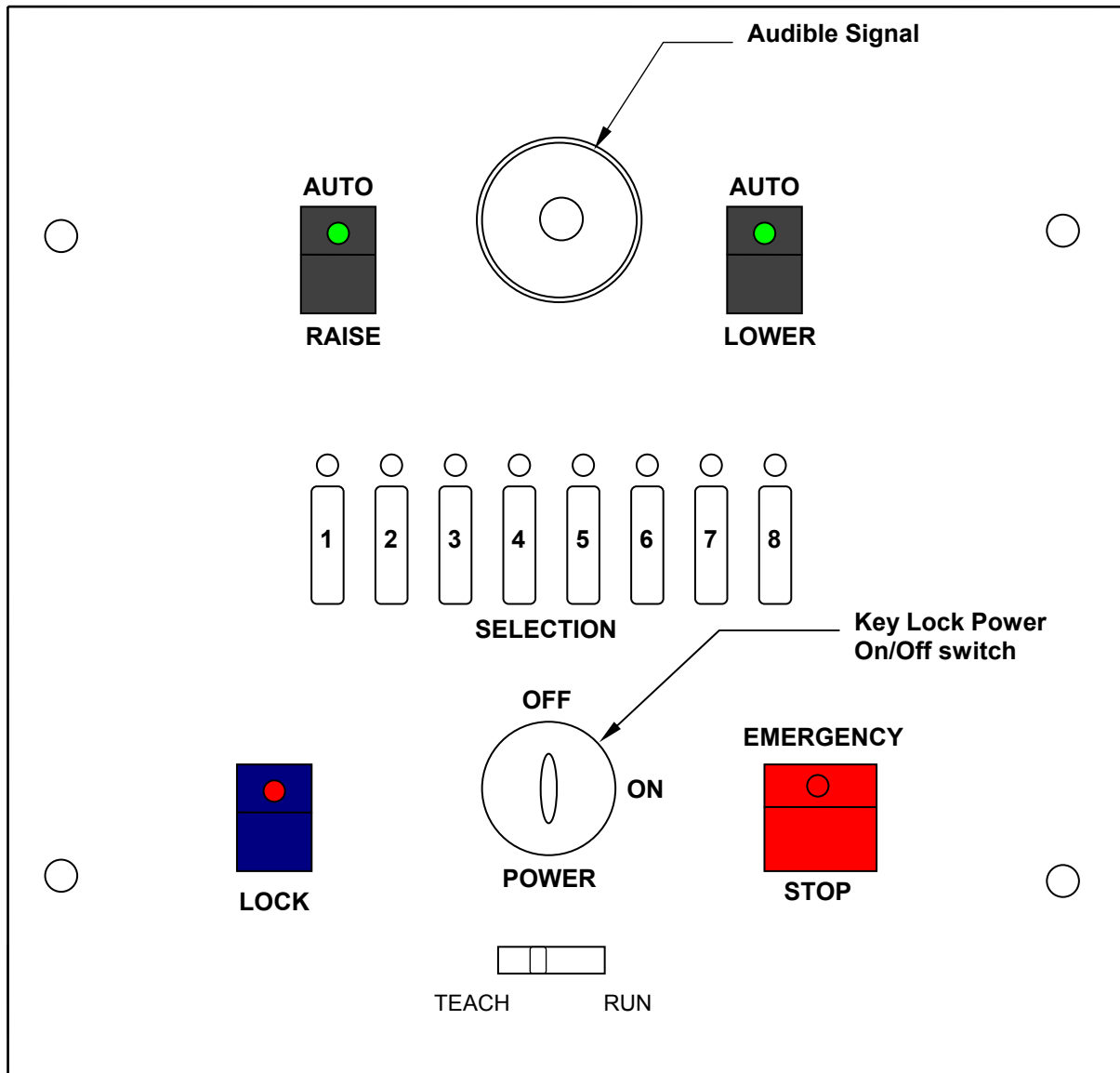

**TYPICAL FRONT PANEL LAYOUT**

**Enclosure:** Painted steel enclosure. Measures 8 in. x 8 in. x 4 in. deep. Provided with knockouts for 1/2 inch or 3/4 inch conduit.

**A Programmable Electronic Motor Control For The Operation  
Of Up To Eight Systems From A Single Location**

# ELECTRONIC CONTROL MODULE FOR MULTIPLE LOWERING SYSTEMS

## Features

- ◆ DESIGNED SPECIFICALLY FOR **RELS-300, CELS-300, MLS-400, MLS-600, and MLS-1100** LIGHT FIXTURE AND CHANDELIER MOTORIZED RAISING AND LOWERING SYSTEMS.
- ◆ LOWERING AND RAISING DISTANCES ARE PROGRAMMABLE BY OWNER OR OPERATOR. SPECIAL 'LOCK' BUTTON PERMITS ALL OF THOSE SYSTEMS SELECTED TO LOCK IN PLACE AT THE SAME TIME.
- ◆ AUDIBLE SIGNAL ALERTS THE OPERATOR TO WHEN ALL OF THE SYSTEMS SELECTED HAVE REACHED THE FULL UP POSITION.
- ◆ COMPUTERIZED CONTROL MODULE PERMITS SYSTEM SELECTION FROM 1 TO 8 TO OPERATE IN ANY ARRANGEMENT.
- ◆ SOPHISTICATED SOFTWARE PROVIDES BUILT IN ASSURANCE THAT NO INADVERTENT PRESSING OF THE WRONG BUTTON WILL RESULT IN PROBLEMS.
- ◆ A KEY LOCK POWER ON/OFF SWITCH PREVENTS UNWANTED PERSONNEL FROM OPERATING THE SYSTEMS.
- ◆ SINGLE BUTTON AUTOMATIC RAISING AND LOWERING WITH LITTLE USER INTERACTION.

## Specifications

**Voltage:** Operates on 105-135 V AC 50/60 Hz.

**Output Rating:** UL/CSA rating 1 HP @ 120V AC.

**Programmable:** Field programmable for raising and lowering times over range of 1 to 1024 sec.

**Switches:** Momentary switches to operate module functions. Key lock power on/off switch. Slide switch for 'Teach-Run' functions. Toggle on/off system selection for eight units.

**LED's:** Indicates operation in process. Shows system selection as being in 'on' mode.

**Audible Signal:** Alerts user that all systems being operated have reached the full 'up' position.

**Emergency Stop:** Over rides any function in process to immediately stop all system action.

**Lockout Logic:** Protects against accidentally pressing the wrong function button and damaging mechanical system components.

**Cycle Memory:** Keeps track of *up/down* cycle-in-process and restores control to that time in the cycle when the power was last removed for any duration.

**Raise & Lower Memory:** Times maintained in EEPROM memory and is not lost during power failures or any time power is removed from the control.

**Connections:** Wires (by others) of each raising/lowering system connects to the terminal blocks for easy wire hookup.

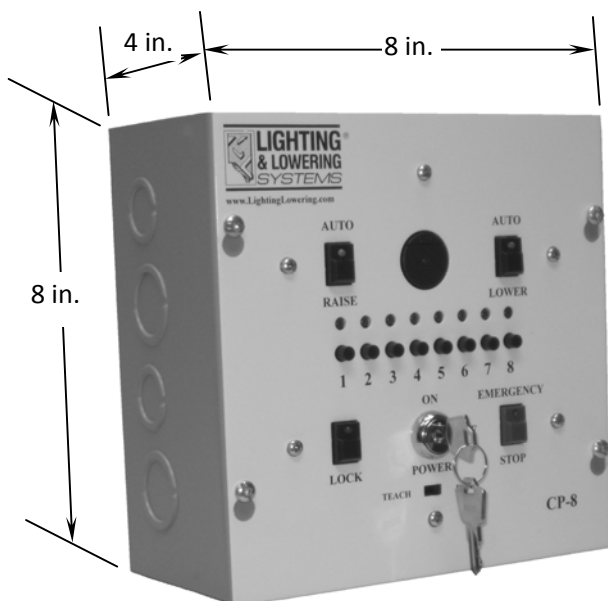

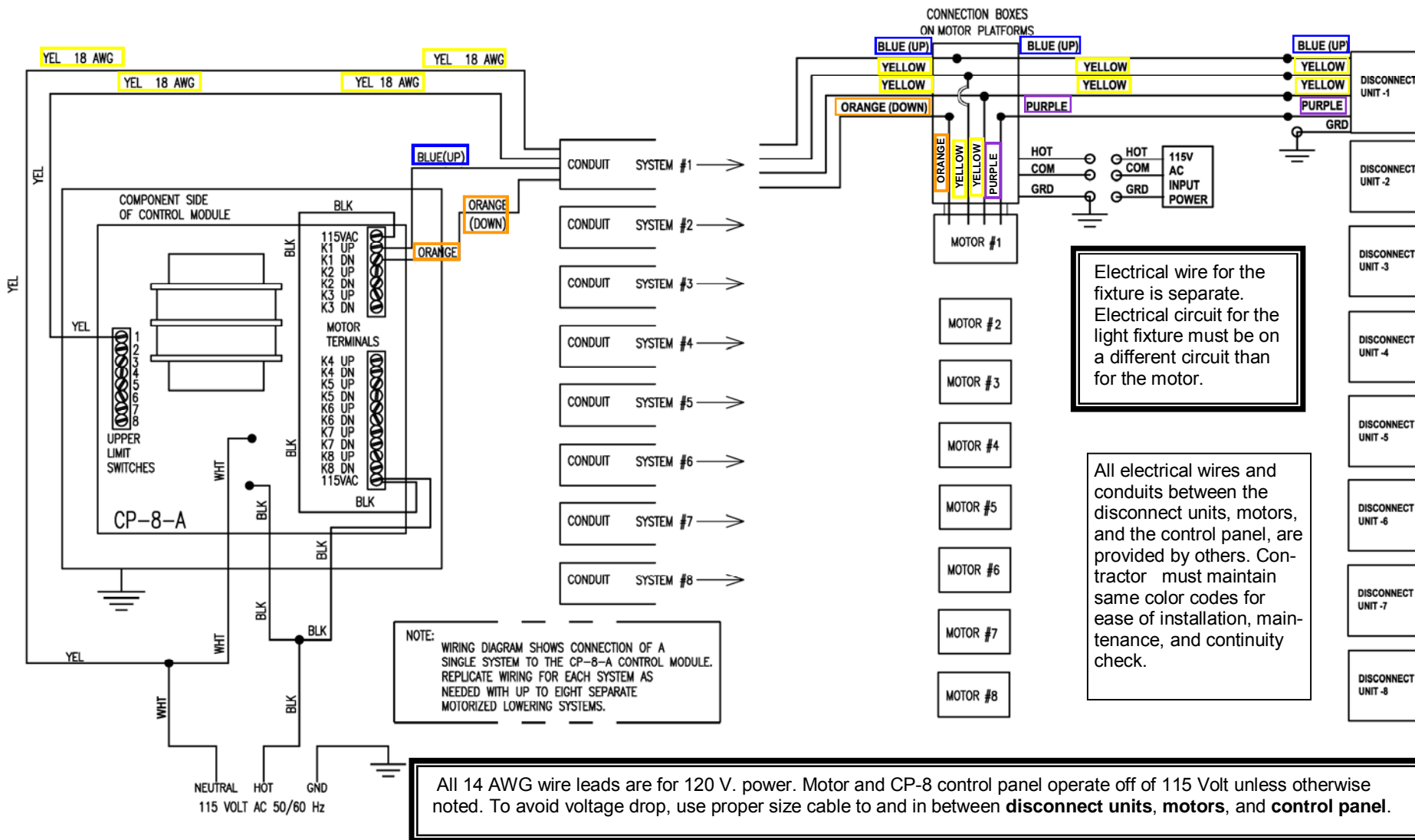

\* Specifications subject to change without notice. Details shown are intended as an application example only. Actual installation details may vary. Contact manufacturer's representative or factory for specific details about special installation application or other information.