

Arm and Disconnect Unit for Pole Mount with CAT6 and power cable for IP Cameras

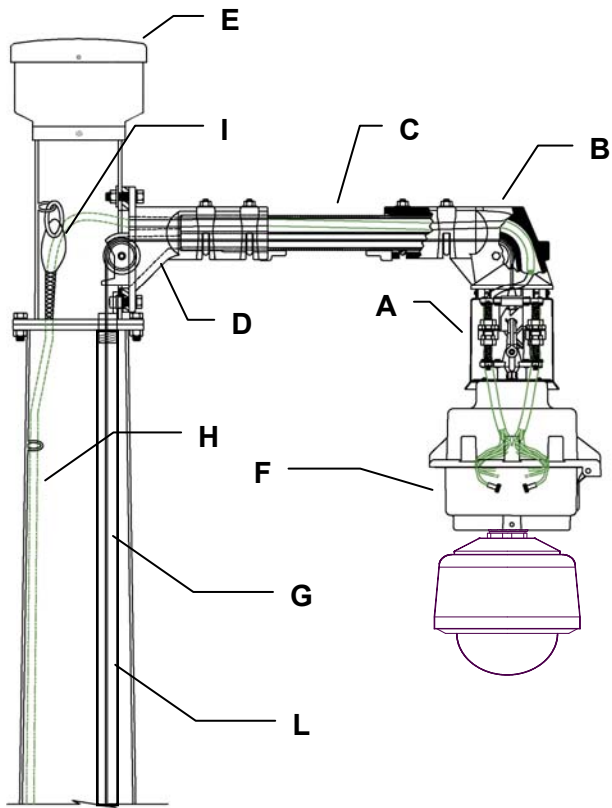

A. ELECTRICAL AND SIGNAL DISCONNECT UNIT WITH MULTI-CONTACT CONNECTOR.

B. DISCONNECT UNIT FITTER WITH PULLEY AND U-BOLT MOUNTING FOR INTERLOCKING NON-ROTATING ARM.

C. DIVIDED PIPE ARM: 2-3/8 IN. O.D. SEPARATES CONTROL CABLE AND ELECTRICAL AND SIGNAL WIRES. POSITION ALIGNED NON-ROTATING.

D. POLE MOUNTED FITTER WITH PULLEY AND U-BOLT MOUNTING. FITTER MOUNTS DIRECTLY TO 6 INCH O.D. TENON AT TOP OF POLE.

E. POLE TOP JUNCTION BOX WITH COVER SLIPS OVER 6" O.D. TENON.

F. CAMERA CONNECTION BOX PROVIDED WITH STABILIZING WEIGHTS. EASY OPEN SWING DOWN DESIGN PERMITS QUICK ACCESS TO ELECTRICAL/SIGNAL WIRES FROM CAMERA ASSEMBLY.

G. CONTROL CABLE CONSTRUCTED OF 5/32 INCH DIA. STAINLESS STEEL 7 X 19 CONSTRUCTION CABLE INSIDE 1 1/2" CONDUIT (CONDUIT BY OTHERS).

H. CONTINUOUS CAT6 IN EXTREME JACKET AND 3-CONDUCTOR POWER CORD, FROM DISCONNECT UNIT TO CABINET WITHOUT THE NEED OF EXTRA CONNECTORS.

I. SIGNAL CABLE STRAIN RELIEF

J. POLE (BY OTHERS).

K. CABINET (BY OTHERS)

L. CONDUIT FOR LOWERING CABLE (BY OTHERS)

TOTAL EPA (inc. arm assy. & camera): 2.50
TOTAL WEIGHT: 95 LBS.

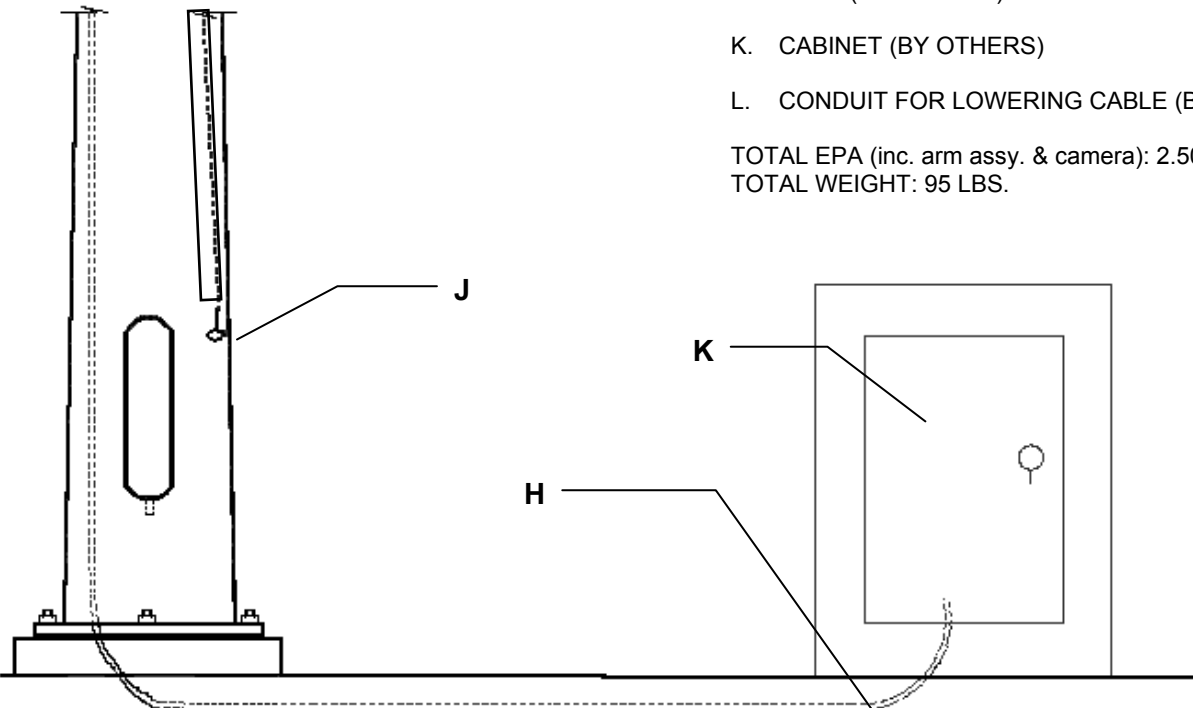

2 Arms with Disconnect Unit for Pole Mounting Multi-Function Surveillance Cameras

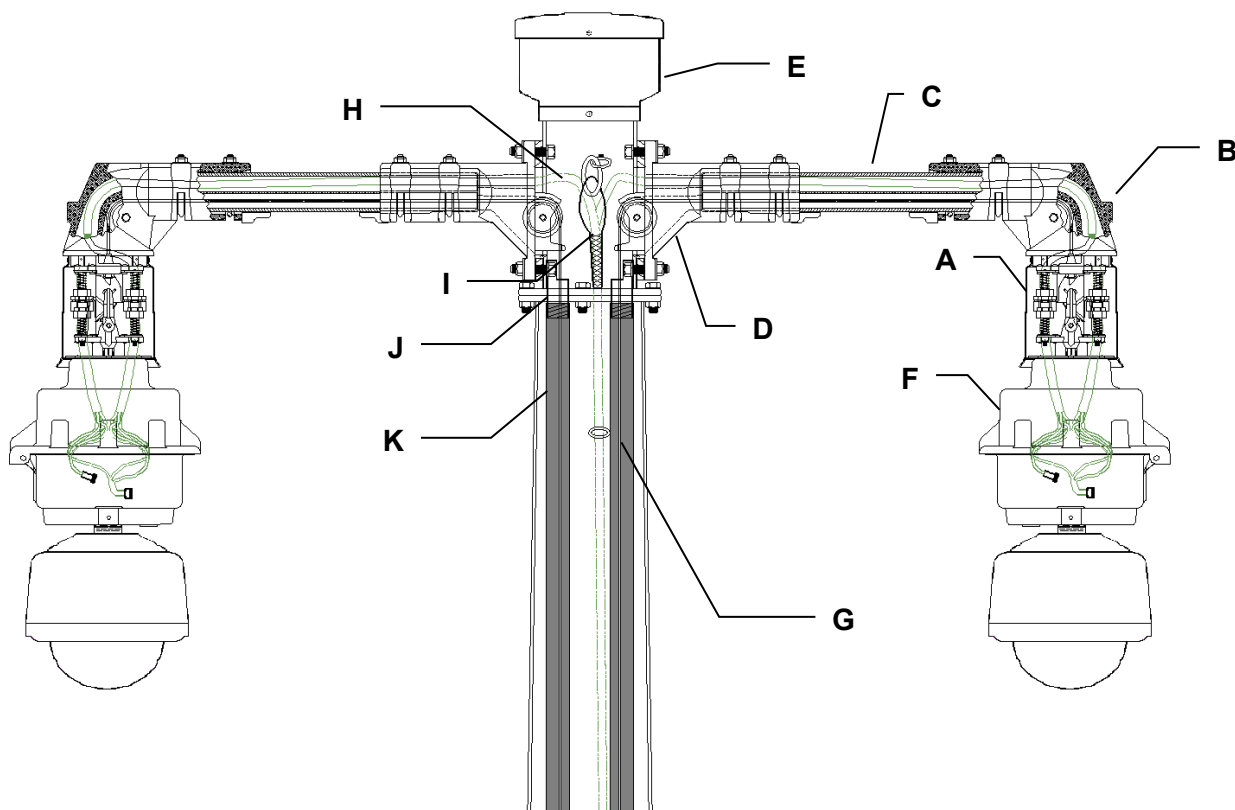

- A. HEAVY DUTY ELECTRICAL AND SIGNAL DISCONNECT UNIT WITH MULTI-CONTACT CONNECTOR (2 per pole).
- B. DISCONNECT UNIT FITTER WITH PULLEY AND U-BOLT MOUNTING FOR INTERLOCKING NON-ROTATING ARM (2 per pole).
- C. DIVIDED PIPE ARM: 2-3/8 IN. O.D. SEPARATES CONTROL CABLE AND ELECTRICAL AND SIGNAL WIRES. POSITION ALIGNED NON-ROTATING (2 per pole).
- D. POLE MOUNTED FITTER WITH PULLEY AND U-BOLT MOUNTING. MOUNTS DIRECTLY TO 6 INCH O.D. TENON ON POLE TOP (2 per pole).
- E. 6" POLE TOP JUNCTION BOX WITH COVER. J-HOOK ALSO PROVIDED FOR STRAIN RELIEF.
- F. CAMERA CONNECTION BOX PROVIDED WITH STABILIZING WEIGHTS. DESIGN TO REPEL WATER. EASY OPEN SWING DOWN DESIGN PERMITS EASY ACCESS TO ELECTRICAL/SIGNAL WIRES FROM CAMERA ASSEMBLY (2 per pole).
- G. CONTROL CABLE CONSTRUCTED OF 5/32 INCH DIA. STAINLESS STEEL 7 X 19 CONSTRUCTION CABLE (2 per pole).
- H. CONTINUOUS SIGNAL CORD WITH CAT6/3-COND POWER FROM DISCONNECT UNIT TO POLE BASE OR TO CABINET WITHOUT THE NEED OF EXTRA CONNECTORS AT POLE TOP (2 per pole). (See attached cable specs).
- I. CORROSION RESISTANT STRAIN RELIEF WITH CONNECTING LINK, FOR COMPOSITE CABLE.
- J. CORROSION RESISTANT THREADED CONDUIT BRACKET FOR ATTACHING CONDUIT.
- K. 1 1/2" PVC CONDUIT TO PROTECT CONTROL CABLE (CONDUIT BY OTHERS).

TOTAL EPA (inc. arm assy. & camera): 5.00 per pole
TOTAL WEIGHT: 190 LBS. per pole

SPECIFICATIONS FOR 16HD ELECTRICAL DISCONNECT UNIT

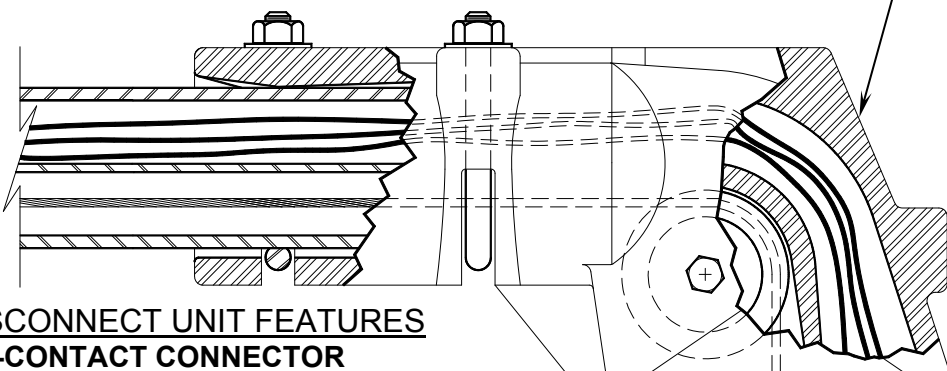

MOUNTING FITTERS
Cast aluminum alloy. Completely isolates the moving control cable from the signal cable. Molybdenum filled nylon pulley has sintered bronze permanently lubricated bearing for maintenance free life. This insures their use for dirty atmosphere and corrosive environments.

Outdoor Model: (Shown)
For 2-3/8" O.D. Galv. pipe. Retrofit, pole, & wall mtg.
Indoor Model: Has upper flange for surface mtg.

DISCONNECT UNIT FEATURES

***MULTI-CONTACT CONNECTOR**
Precision mating upper (socket half of connector) and lower (pin half of connector) portions aided with stainless steel spring assisted guides. Connector provides up to 16 electrical and signal contacts to handle the wide variety of cameras and components in today's marketplace. Both halves of connector are spring assisted to minimize environmental vibrations and provide continuous resistant forces to maintain connector closure and help in ejecting of connector halves during the unlocking sequence of the disconnect unit. Connector halves designed as separate modules for easier removal and replacement should changes be needed for camera and component equipment upgrades. Connector is self-aligning and self-adjusting and is environmentally sealed. All contacts are copper with MIL SPEC **nickel plating** and 30 microinch **gold plating** over nickel. The gold plating passes the Industrial Mixed Flowing Gas test designated to create corrosion. Socket contacts have beryllium copper springs that assure constant contact with pins.

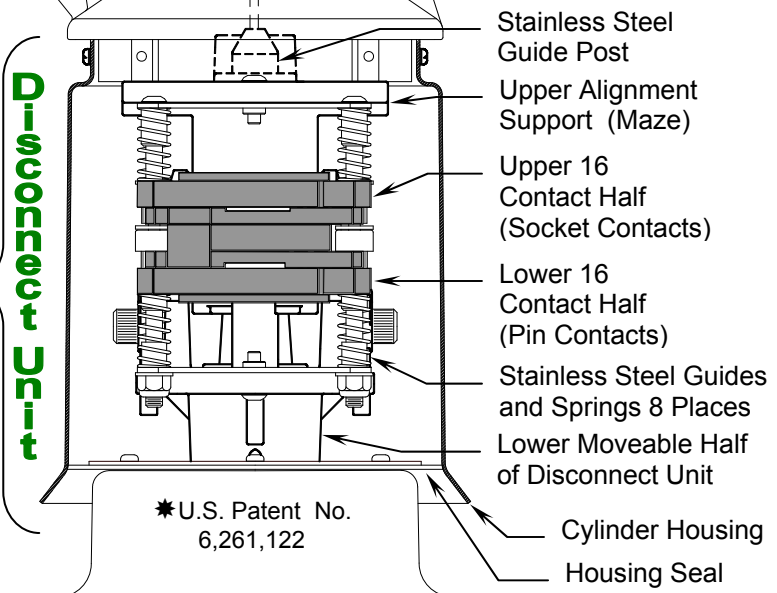

DISCONNECT UNIT

*U.S. Patent No. 6,261,122

STRUCTURAL COMPONENTS

Upper alignment support and lower moveable half of disconnect unit are high strength cast aluminum alloy 356-T6. Main guide post and structural support arms are precision cast stainless steel.

CYLINDER HOUSING

Standard housing is hydrospun heavy gauge aluminum. Painted finish is optional.

HOUSING SEAL

Flexible environmental seal at lower housing opening is standard neoprene. Seal swipes and conforms to interior of cylinder housing during all operating stages of the disconnect unit.

CAMERA CONNECTION BOX

Two piece hinging cast aluminum splicing box has large capacity for camera power and signal leads. Features vibration resistant latching mechanism.

ELECTRICAL DISCONNECT UNIT FOR MULTI-FUNCTION CAMERAS

OPERATION OF THE MULTI-CONTACT CONNECTOR

Distance 'D' is the total distance that the disconnect unit must travel to lock and unlock. This unique design (patented) by Camera Lowering Systems provides spring assisted upper and lower portions of the connector that splits the total travel distance in half, thereby equalizing the retaining forces required to assure a uniform seal. Because the upper half (socket contacts), and the lower half (pin contacts) float within the disconnect unit, the connector is isolated from vibrations that would affect signal discontinuity.

LOCKED POSITION

When the disconnect unit is in the locked position, the multi-contact connector has all contacts engaged. Springs are slightly compressed to provide equal and constant pressure against the two halves to maintain an environmental seal.

LOCKING POSITION & UNLOCKING POSITION

During the operation to lock or unlock the disconnect unit, the springs of both halves of the connector compress in equal proportions and stainless steel

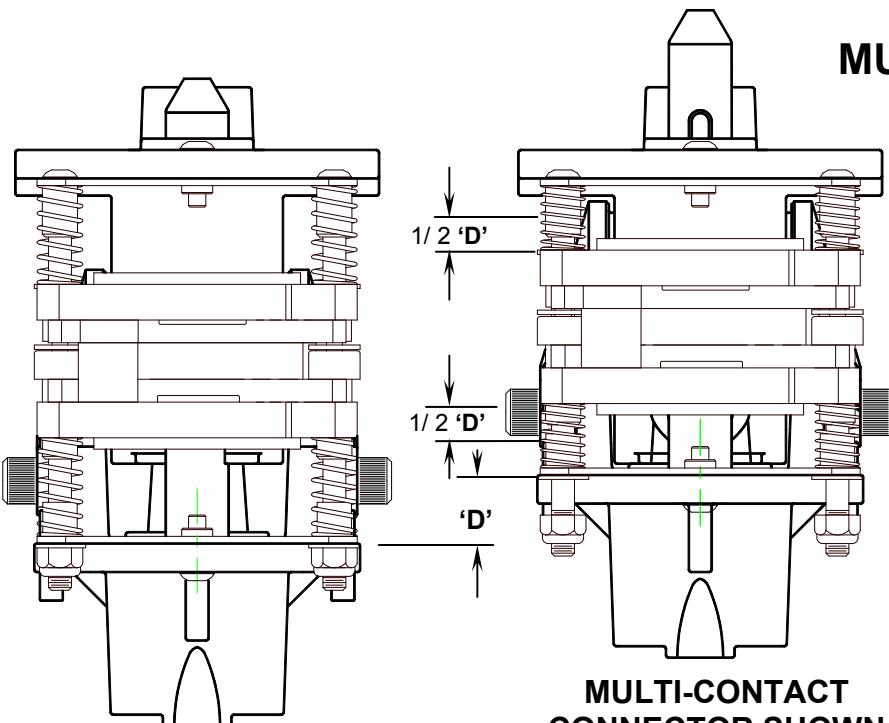

MULTI-CONTACT CONNECTOR SHOWN IN LOCKED POSITION

MULTI-CONTACT CONNECTOR SHOWN IN LOCKING OR UNLOCKING POSITION

CONTACTS AND WIRES

- Twin connectors provide up to 16 Heavy Duty size 12 gold plated over nickel, pure copper electrical contacts.
- Contacts are securely contained within a heavy duty polymer body.
- Upper socket and lower pin contact groups are permanently sealed to the connector body with 'Superflex' silicone adhesive rubber sealant. This provides a tough waterproof rubber seal formulated to withstand extreme temperature cycling and severe weather conditions.
- Signal shielding and drain wires are continuous.
- Wires are 10 conductor plus GND electrical and signal wires (CAT6 and 3-conductor 14 AWG power cable). See attached cable specs. The contact connector shall accommodate IP camera connections suitable for 1000 BASE-T (Gigabit Ethernet).
- A one piece composite cable is provided from disconnect unit to cabinet. (Length to be specified) No additional connectors are required at the top of the pole, or anywhere else between the disconnect unit and the cabinet.

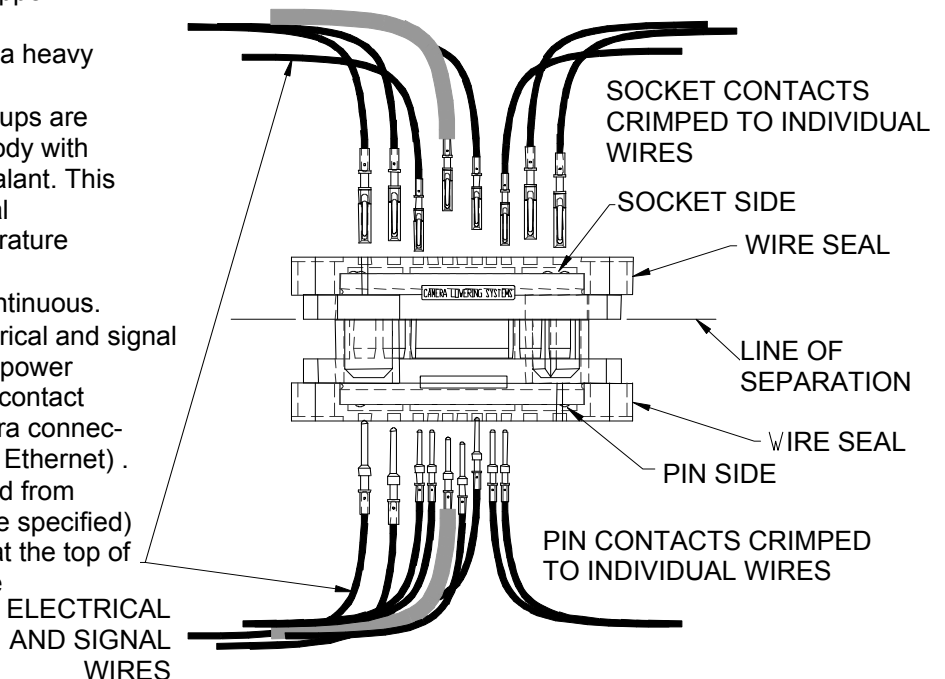

16HD DISCONNECT UNIT With CAT6 cable for IP Cameras

OPERATION OF THE MULTI-CONTACT CONNECTOR

guide posts move through linear bearings as the support arms of the disconnect unit move into the proper position within the tracking guide. Electrical and signal contacts remain fully engaged and the camera is still operational.

RAISING POSITION

The connector assembly utilizes precision machined 4 stainless steel guides to align the two halves of the connector. These guide pins are longer than the communication pins and must engage first and disengage last. These pins are connected to the disconnect unit causing the unit to be grounded per U.L./CSA ratings of the product. In addition to these pins, a 3-way guide is also used for alignment. A set of alignment posts built into the connector halves serve as the final guides to assure that all pin and socket contacts are perfectly aligned before engagement.

LOWERING POSITION

As the disconnect unit begins to unlock, the springs expand and the guide posts begin to separate. The last parts of the connector to disengage are the electrical and signal contacts. Any ground wires or shielding use a longer pin contact to assure that they are the very last to disengage before the camera is lowered for servicing.

Electrical Disconnect Unit (EDU) Specification Guide

- ❖ The signal and electrical disconnect unit shall meet or exceed sine vibration tests of 3.5 g's within the frequency range of 5-60 Hz in all three axes for minimum of six 5-minute cycle each axes. It shall meet or exceed random vibration tests of frequency range 60-1000 HZ at .025 g2/Hz applied for 30 minutes in each of the three axes. It shall have results to exhibit no signal or electrical discontinuities greater than 10 microseconds. Tests applicable to Electrical Disconnect Unit and attached components.
- ❖ Contact connections shall be capable of passing EIA-232, EIA-422, EIA-485 and Ethernet data signals and 1 Vp-p video signals, as well as 120VAC, 9-24VAC and 9-48VDC. EDU and cable meets ANSI/TIA/EIA-568-B.2-1 standards.
- ❖ The EDU shall have a 3-way tracking guide and support. It shall be constructed of precision cast high strength aluminum alloy 356-T6. A permanently fixed position piece incorporating a special tracking guide system permits the moveable portion of the *Disconnect Unit* to align in the same position every time the system is operated, thereby eliminating the need to re-orientate the camera. The Electrical Disconnect Unit shall have twin high strength notches securing the load of the *Lower Contact Assembly* and camera.
- ❖ The MULTI-CONTACT Connector assembly shall be modular for easy installation and retrofit requirements. All pin and socket contacts shall be insertable and removable. The connector shall have 16 copper alloy C14500, size 12 contacts (.100" Dia.) rated at 35 Amps with gold plating over nickel per MIL-G-45204.
- ❖ All hardware shall be corrosion resistant stainless steel. It shall have a self-aligning and self-adjusting mechanical system comprised of two principal assemblies:
Two UPPER CONTACT HALVES shall house the socket contacts. It shall incorporate spring assisted polymer contact body with precision-machined guideposts. The socket contact body shall have integral guideposts for precise contact alignment.
Two LOWER CONTACT HALVES shall house the pin contacts comprised of spring assisted polymer contact body with precision-machined guidepost receivers. The pin contact body aligns with guideposts of integral socket body guideposts.
- ❖ **CYLINDER**-The cover shall be a one-piece hydro-spun heavy gauge aluminum. The cylinder must utilize stainless steel mounting hardware with O-Ring imbedded washers. The unit must exceed the ingress protection rating of IP55.
- ❖ The unit shall have a guidepost constructed of precision cast high strength stainless steel. It shall utilize a cast-in-place guide bar for precise alignment of *Lower Contact Assembly* with the fixed portion of the *EDU*.
- ❖ If required, connectors in the pole top junction box and camera junction box are provided by others.

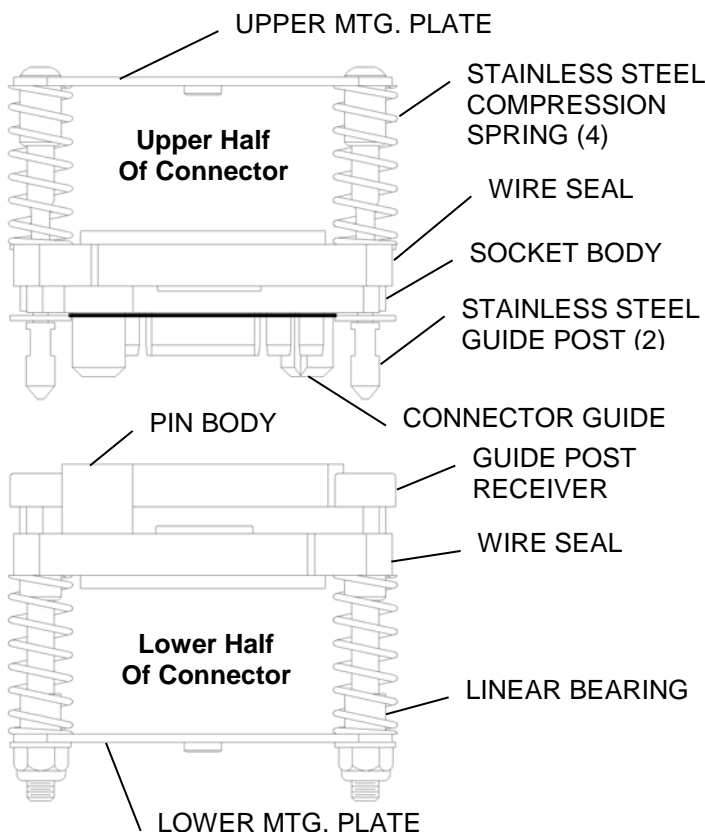

❖ THERE ARE TWO LOCKING CAMS that suspend the weight of the camera and camera junction box when the unit is in the locked position. The Locking Cams are rated to handle loads up to 400 lbs with a 7:1 safety factor. When in the locked position, all stress is released from the lowering cable.

SPECIFICATIONS FOR OTHER COMPONENTS FOR POLE MOUNT

❖ A DISCONNECT UNIT FITTER shall be provided made of heavy duty cast aluminum alloy to fit a 2-3/8 inch (60.3mm) outside diameter *Divided Pipe Arm*. Two U-bolt pipe clamps shall be used to rigidly hold the *Divided Pipe Arm*. The fitter is designed to completely isolate the moving *Control Cable* from the electrical and signal wires. It shall contain a molybdenum impregnated nylon pulley providing high strength and low resistance for the moving *Control Cable*, thereby increasing the life of the cable. The pulley shall have a permanently lubricated bearing.

❖ The system shall have a POLE MOUNTED FITTER made of heavy duty cast aluminum alloy to fit 2-3/8 inch (60.3mm) O.D. *Divided Pipe Arm*. It shall utilize a cast-in-place cable stop to prevent cable connections from entering pulley. It shall contain a molybdenum impregnated nylon pulley with a permanently lubricated bearing. Two U-bolt pipe clamps shall be used to rigidly hold the *Divided Pipe Arm*. The fitter shall be designed to bolt directly to a 6" (152.4mm) Diameter pole top. The system shall have a horizontal divided pipe arm that fits inside and connects the Disconnect Unit Fitter with the Pole Mounted Fitter. It shall be made of 2-3/8 inch (60.3mm) O.D. with 1/4" (6.4mm) wall thickness steel pipe with galvanized finish standard (polyester powder coat painted finish optional). The pipe shall be divided entire length to keep *Control Cable* and electrical/signal wires separate. Arm shall be position aligned non-rotating type incorporating interlocking positioning keys.

❖ The system shall have a POLE TOP CONNECTION BOX made of cast aluminum. The box shall be 8-inch (203mm) diameter with the bottom portion made to fit over a 6" (152.4mm) O.D. Diameter pole top tenon. It shall be secured to the pole using stainless steel screws. The connection box shall have a cast aluminum cover retained by stainless steel screws. The box shall incorporate bosses for direct mounting of cord strain relief brackets and cord grips. It shall also be used to terminate the socket connectors at a terminal block located in the pole-top connection box. If preferred, the Signal Cable can be a one piece from disconnect unit to pole base or cabinet to eliminate need of a connector at top of pole.

❖ The system shall utilize a CONTROL CABLE (mechanical raising and lowering cable) made of type 316 Stainless Steel 5/32 inch (3.9mm) diameter 7 x 19 construction cable. The cable should be manufactured so as not to unwind or become unraveled during the raising and lowering operation. Minimum breaking strength shall be 2400 lbs. One end of the cable shall have a heavy-duty Stainless Steel connecting link. The control cable shall be the only cable that moves when the camera is raised and lowered.

❖ The system shall also have a CAMERA CONNECTION BOX. It shall be a two piece design for easy camera mounting. Both sections shall be made of corrosion resistant cast aluminum. The top half shall be mounted and gasketed to the bottom of the disconnect unit. Inside the top half, it shall have provision to mount additional weights for lightweight cameras or other equipment. All parts shall be made of extra heavy construction. The Camera Connection Box shall be adaptable to all brands of cameras. The two piece construction shall feature a lower box that hinges down for easy access to wiring. It shall contain a large capacity-splicing compartment for camera power, signal leads, and connectors. All hardware shall be made of stainless steel.

❖ An LT-CC LOWERING TOOL shall be supplied with each order. It is a portable lowering tool consisting of the gearbox, disc brake, frame, and lowering cable. The gearbox shall be of heavy-duty design. It shall incorporate solid steel heated treated gears for maximum durability and strength. The gearbox shall be equipped with a special automatically actuated disc brake for load holding ability and the prevention the load from freewheeling. This is essential for all lifting operations. The winch has a 3:1 Gear reduction to reduce the effort required to raise and lower the camera assembly. The frame shall be of a heavy-duty design with brackets making the unit stable when mounted in the pole handhole. The frame shall have a pulley with a permanently lubricated bearing. The raising and lowering (control) cable shall be made of type 316 Stainless Steel 5/32 inch (3.9mm) diameter 7 x 19 construction cable It shall come with a heavy-duty stainless steel swivel.

❖ Length of tool cable shall be long enough to allow cable to wind evenly on winch drum and not bind during operation.

CAMERA
LOWERING
SYSTEMS

INTERLOCKING ARM & FITTERS
PROVIDES POSITIVE NON-ROTATING POSITIONING
OF PIPE ARM FOR ALL OUTDOOR
POLE AND WALL MOUNTED LOWERING SYSTEMS

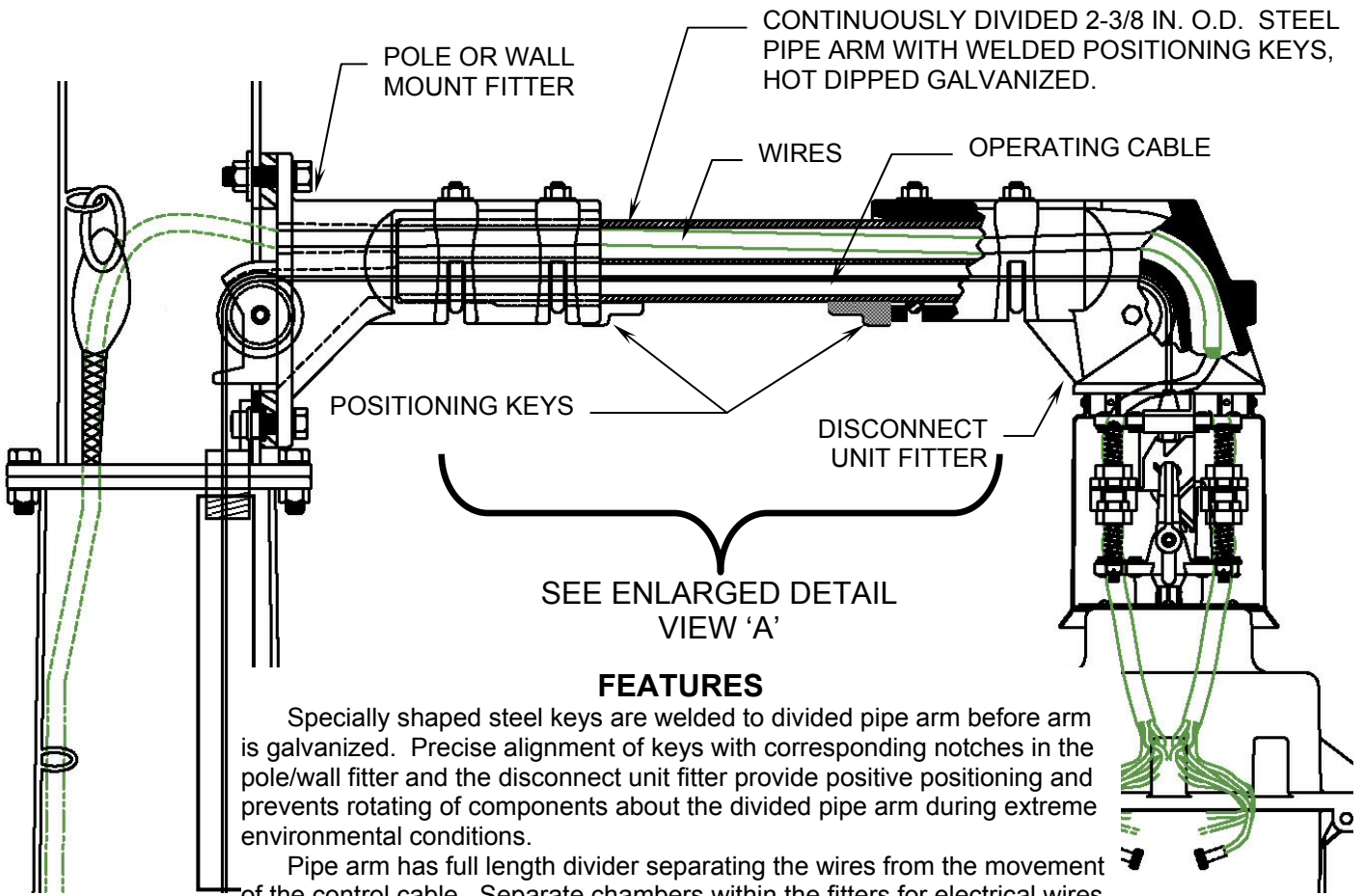

FEATURES

Specially shaped steel keys are welded to divided pipe arm before arm is galvanized. Precise alignment of keys with corresponding notches in the pole/wall fitter and the disconnect unit fitter provide positive positioning and prevents rotating of components about the divided pipe arm during extreme environmental conditions.

Pipe arm has full length divider separating the wires from the movement of the control cable. Separate chambers within the fitters for electrical wires and the control cable assures complete protection to the wires during the operation of the system.

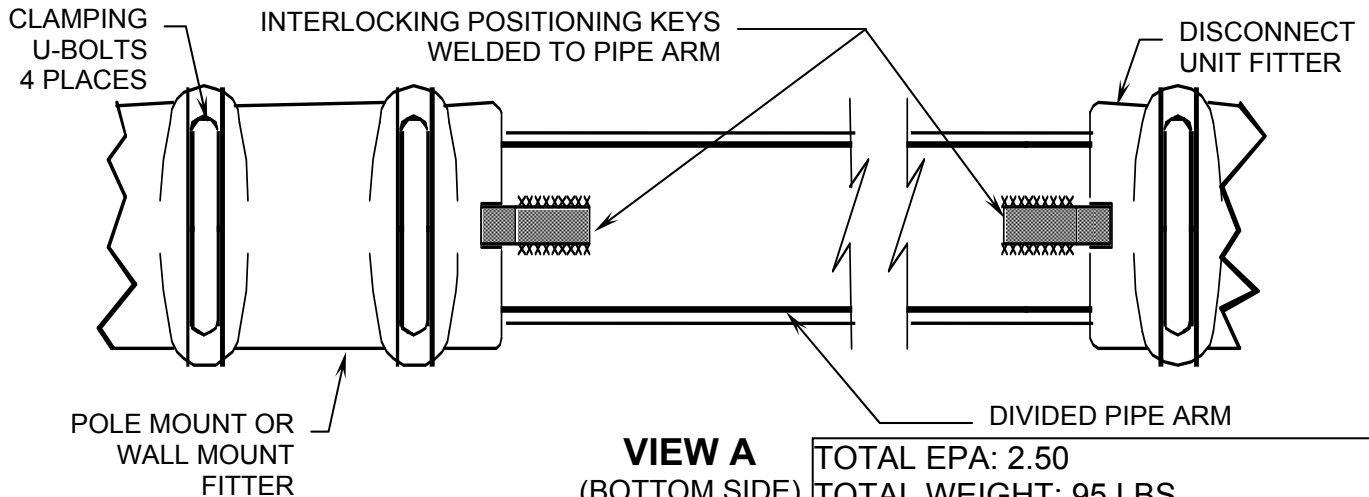

VIEW A
(BOTTOM SIDE)

TOTAL EPA: 2.50
TOTAL WEIGHT: 95 LBS
(includes arm, disconnect unit, pole and camera junction boxes, & camera)

INTERLOCKING ARM & FITTERS

PROVIDES POSITIVE NON-ROTATING POSITIONING OF
PIPE ARM FOR ALL OUTDOOR
POLE AND WALL MOUNTED LOWERING SYSTEMS

ARM CROSS SECTION

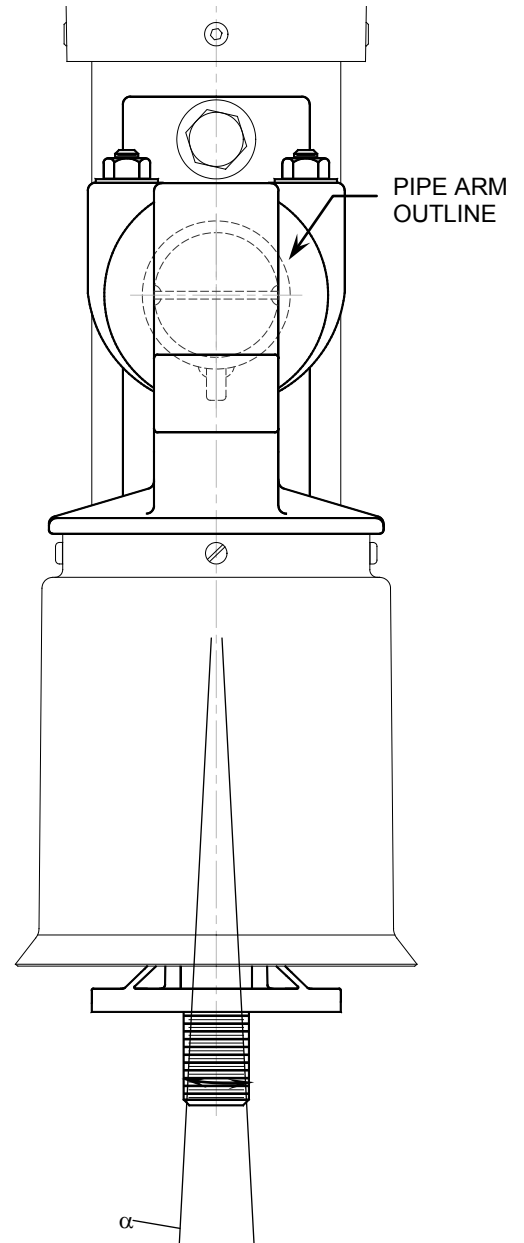
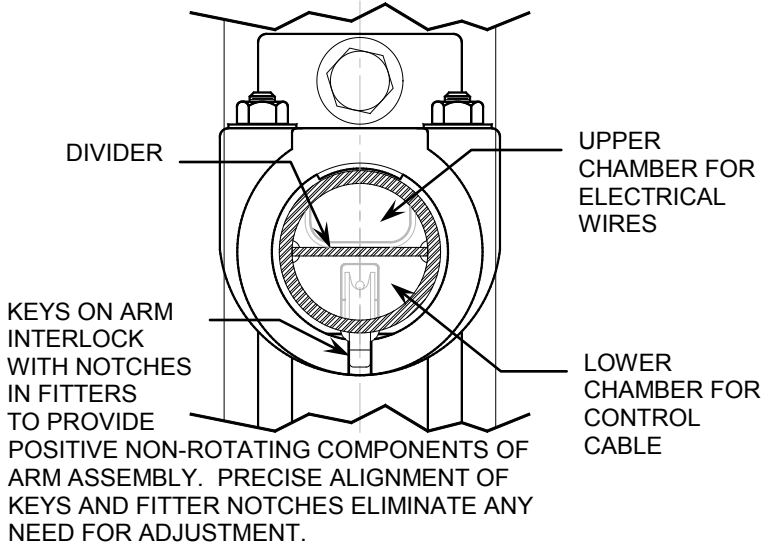

END VIEW

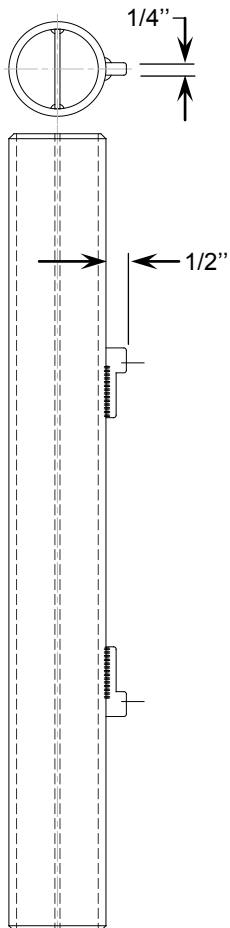

DETAILS OF FEATURES

NOTE: WHEN THE INTERLOCKING POSITIONING KEYS OF THE ARM ASSEMBLY ARE MATED WITH THE CORRESPONDING NOTCHES IN THE FITTERS, THE POLE SHAFT MUST BE PLUMB FOR THE PROPER OPERATION OF THE SYSTEM.

ANGLE α : The angle α shown in the END VIEW is based on mechanical tolerances between mating parts and should not exceed a total of $1/2^\circ$. This deviation from plumb will not affect the operation of the components of the arm assembly. All tolerances are based on the pole shaft being plumb when installed.

PIPE ARM: (See Fig. 1) Constructed of 2 inch structural steel pipe having an outside diameter of 2-3/8 inch. Positioning keys are permanently welded to the pipe arm at precise positions that align with notches in the ends of each of the fitters. Arm finish is hot dip galvanized after all welding is completed. Optional finishes over the galvanizing are available to match the color of the pole. Ends of the pipe arm bottom out against the inside of the fitters a small fraction of an inch before the keys bottom out in the notches to provide a secure fit.

The pipe arm is installed complete with the rest of the arm components at the factory and is pre-wired to eliminate any need for adjustment in the field.

Fig. 1

Features And Benefits

- Innovative cross-web design allowing for maximum pair separation, increasing key electrical performance parameters
- **Gel-filled construction to prevent moisture migration in underground and wet applications**
- Wide temperature range for extreme weather environments
- Made in U.S.A.

Applications

- Data transmission rates up to 2.4 Gb/s
- 1000 BASE-T (Gigabit Ethernet)
- 100/10 BASE-T (IEEE 802.3)
- 52/155 Mbps ATM
- Duct and outdoor conduit installations

Standard Compliances

- ANSI/TIA 568-C.2
- ISO 11801 (Category 6)
- ICEA S-102-700 (Category 6)
- Telcordia (Bellcore) Specification GR-421-CORE Water Penetration Requirement
- RoHS Compliant Directive 2002/95/EC

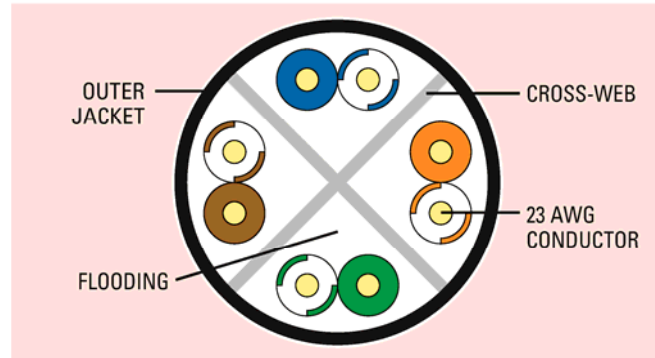

CONSTRUCTION

Conductors

- 23 AWG solid bare annealed copper

Insulation

- Polyolefin

Color Code

- Pair 1: Blue-White/Blue
- Pair 2: Orange-White/Orange
- Pair 3: Green-White/Green
- Pair 4: Brown-White/Brown

Separator

- Cross-web

Flooding Compound

- Waterproof gel

Jacket

- UV- and Abrasion-Resistant Polyethylenes

PHYSICAL DATA

Nominal Cable Diameter (in)	0.250
Nominal Cable Weight (lbs/1000)	25
Minimum Bend Radius (in)	1.0
Maximum Pulling Force (lbs)	32
Temperature Rating (°C)	
Installation:	-30 to +60
Operation:	-45 to +80

ELECTRICAL CHARACTERISTICS

DC Resistance (max) Ohms/100 m (328 ft) @ 20°C	8.9
DC Resistance Unbalance (max) Individual Pair %	3.0
Delay Skew (max) ns/100 m	45
Nom. Velocity of Propagation % Speed of Light	69
Characteristic Impedance Frequency (f): 1-250 MHz	Ohms 100 ± 15

ELECTRICAL PERFORMANCE

Frequency MHz	PSACR* (min)	ACR* (min)	Insertion Loss (max)	PSNEXT (min)	NEXT (min)	PSACRF (min)	ACRF (min)	Return Loss (min)
1	70.3	72.3	2.0	72.3	74.3	64.8	67.8	20.0
4	59.3	61.5	3.8	63.3	65.3	52.8	55.7	23.0
10	51.3	53.3	6.0	57.3	59.3	44.8	47.8	25.0
16	46.7	48.7	7.6	54.2	56.2	40.7	43.7	25.0
20	44.3	46.3	8.5	52.8	54.8	38.8	41.7	25.0
31.25	39.2	41.2	10.7	49.9	51.9	34.9	37.9	23.6
62.5	29.9	32.0	15.4	45.4	47.4	28.9	31.8	21.5
100	22.5	24.5	19.8	42.3	44.3	24.8	27.8	20.1
200	8.8	10.8	29.0	37.8	39.8	18.8	21.8	18.0
250	3.5	5.5	32.8	36.3	38.3	16.8	19.8	17.3

Note: Values are expressed in dB per 100 m (328 ft.) length @ 20° C.

*PSACR & ACR not specified in ANSI/TIA 568-C.2

N-Composite Cord Specifications:

3-#14 AWG POWER CABLES (Green, White, Black)

Voltage Rating: 600V.

Water & Sunlight Resistant

Temp. Rating: 105c

U.L. Ampacity Rating for 14 AWG Flexible Cord: 18

CABLE ASSIGNMENTS:

BLACK: POWER (HOT)

WHITE: NEUTRAL

GREEN: GROUND (EARTH)

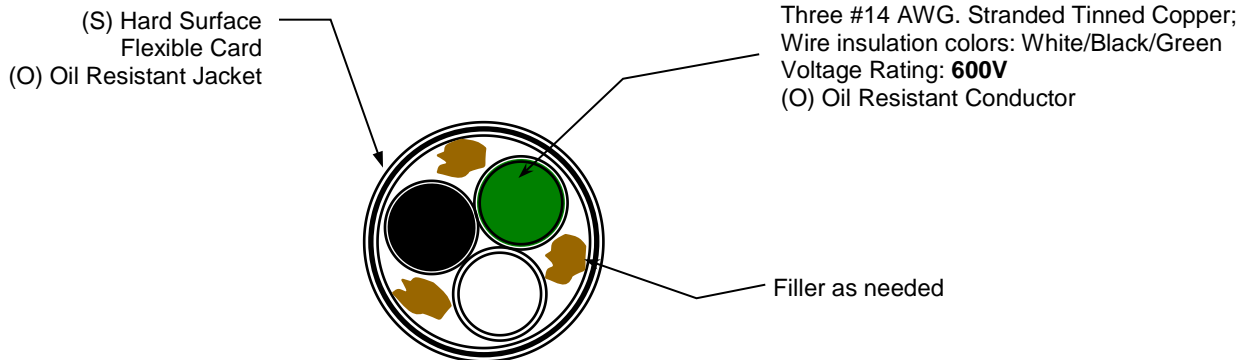

SUPPORT GRIPS Standard Duty, Closed Mesh

Standard closed mesh support grips are designed for loads up to 600 lbs. with vertical runs of up to 100ft. The different cord grips are used to support electrical/signal cable with a cable diameter ranging from 0.22" to 0.99". Closed mesh support grips have a loop to hang from the eye hook at the top of the pole/tower structure. Support grips are woven of corrosion-resistant tinned-bronze wire.

Optional stainless steel wire mesh also available

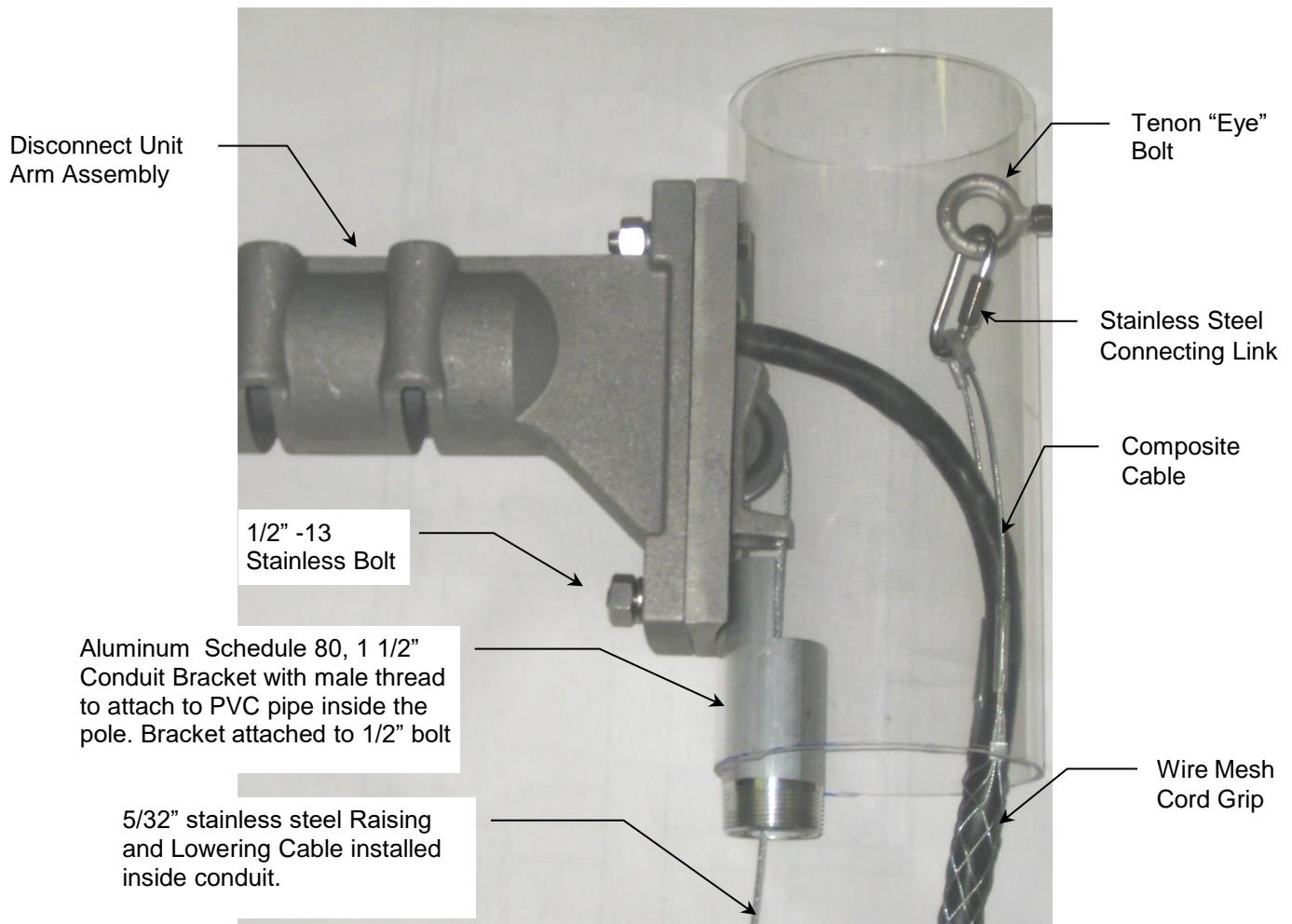

Design **CDP-16HD** SERIES
Pole Mounting Disconnect Unit
Measurements

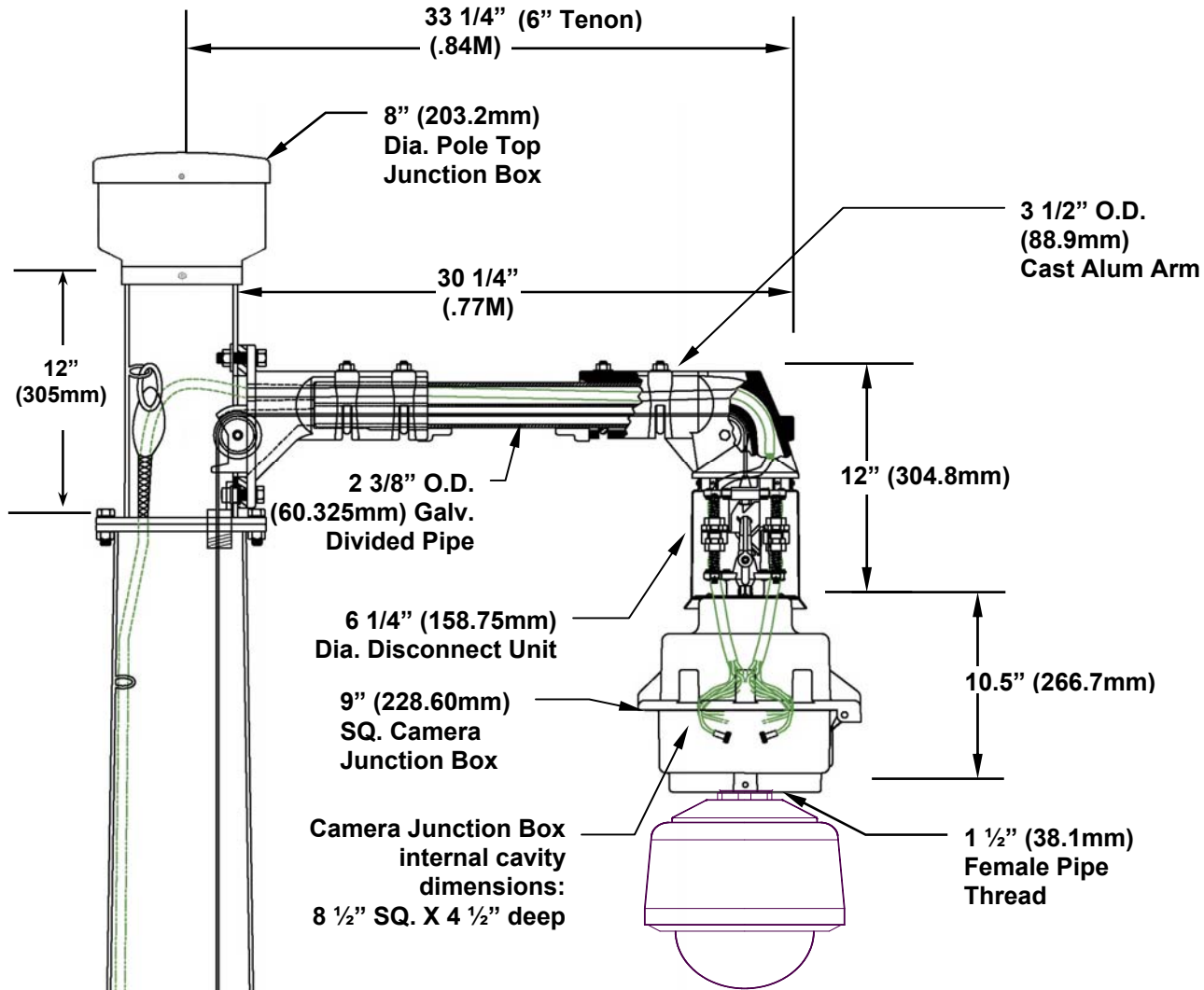

Disconnect Unit Load Capacity:

200 lbs (91kgs) with a 12:1 safety factor
400 lbs (182kgs) with a 6:1 safety factor
600 lbs (273kgs) with a 4:1 safety factor

Complete CDP with Arm Assembly Load Capacity:

200 lbs (91kgs) with a safety factor of 9:1

Operating Temperature Range: NEMA TS2 -34C to +74C, 100% Humidity

Wind load Rating: 150mph (242kmph) w/1.3 Gust with 1.65 safety factor

Total EPA: 2.50

Total Weight: 95 lbs (43 kgs)

(Includes arm, disconnect unit, camera junction box, pole top junction box, and camera)

Camera Junction Box Specifications

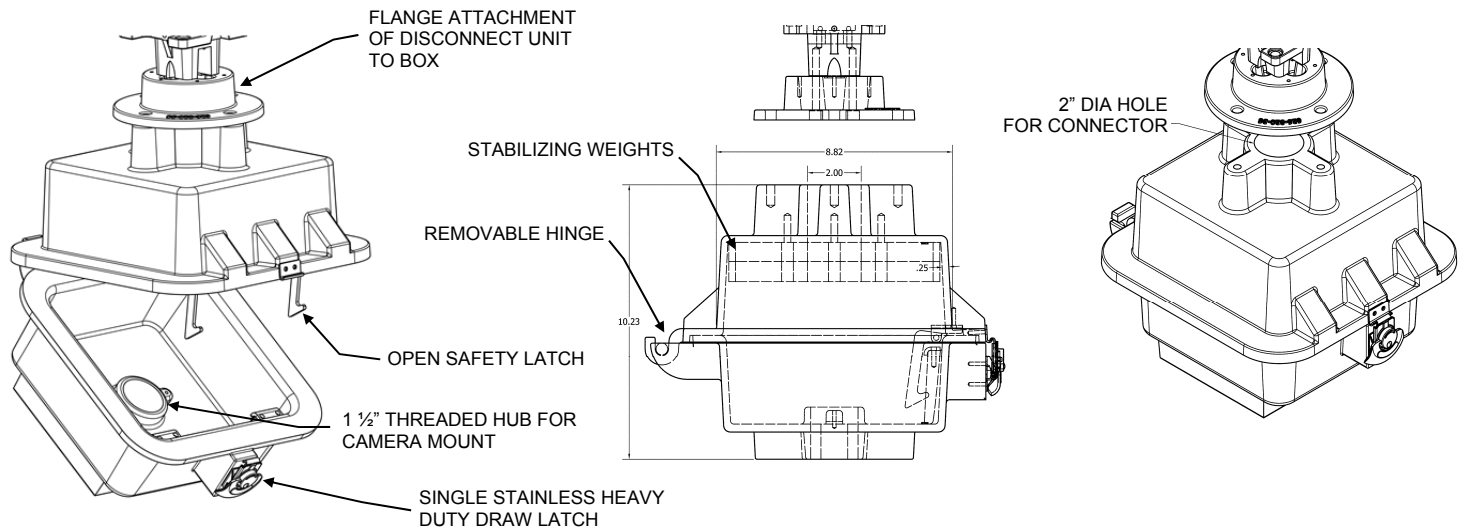

The Camera Junction Box shall be a two piece design for easy camera mounting and wiring connection

- The top half shall be mounted and gasketed to the bottom of the disconnect unit flange.
- Flange assembly shall extend into the cylinder of the disconnect unit and designed to repel water. The gasket shall be made of neoprene.
- The Camera Junction Box must exceed the ingress protection rating of IP55.
- Inside the top half, it shall have provision to mount additional weights for lightweight cameras or other equipment.
- There shall be an option to mount the stabilizing weights on the outside of the box.
- Total weight of Camera Junction box with weights: **45 lbs.**
- Made of extra heavy construction.
- The Camera Junction Box shall be adaptable to all brands of cameras. It shall be able to accommodate cameras with a 1 1/2" threaded mount, or a flange mount.
- There shall be two open safety latches to keep the bottom half of the box from flying too far open.

- The two piece construction shall feature a lower box that hinges down for easy access to wiring. It shall contain a large capacity-splicing compartment for camera power, signal leads, and connectors.
- The two-piece clamshell is designed with a removable hinge on one side, and a single latch on the opposite side.
- Both sections shall be made of corrosion resistant cast aluminum.
- In between the two halves, there shall be a gasket made of neoprene, to resist moisture.
- For ease of attachment, disconnect unit flange attaches to the Junction Box from outside of the box.
- Bottom of box must have a screened 'breather hole' for moisture to escape.
- All hardware shall be made of stainless steel.
- There shall be one heavy duty stainless steel spring-loaded Draw Latch to lock the two halves of the Camera Junction Box together.

POLE TOP JUNCTION BOX

DIMENSIONS

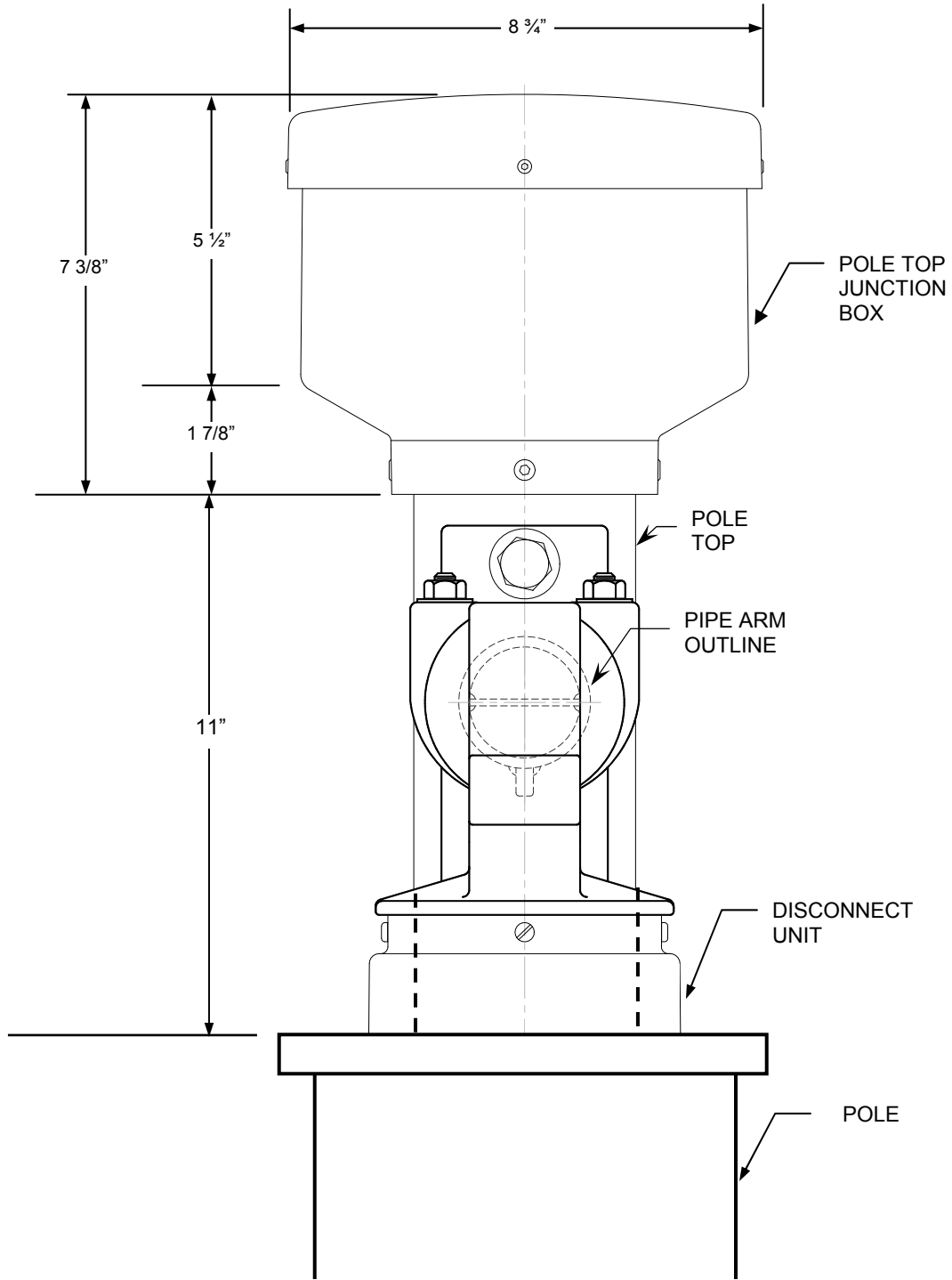

END VIEW

All gearboxes and lowering tool frames are of heavy-duty design to provide reliability, long life, and ease of operation. They incorporate solid steel heat-treated gears for maximum durability and strength. All are equipped with a special automatically actuated disc brake for better load holding ability and the prevention of the load free wheeling. They are essential for lifting operations. Also available for permanent installation or portable use indoors or outdoors for wall mounting, tower mounting, or different kinds of pole mounting.

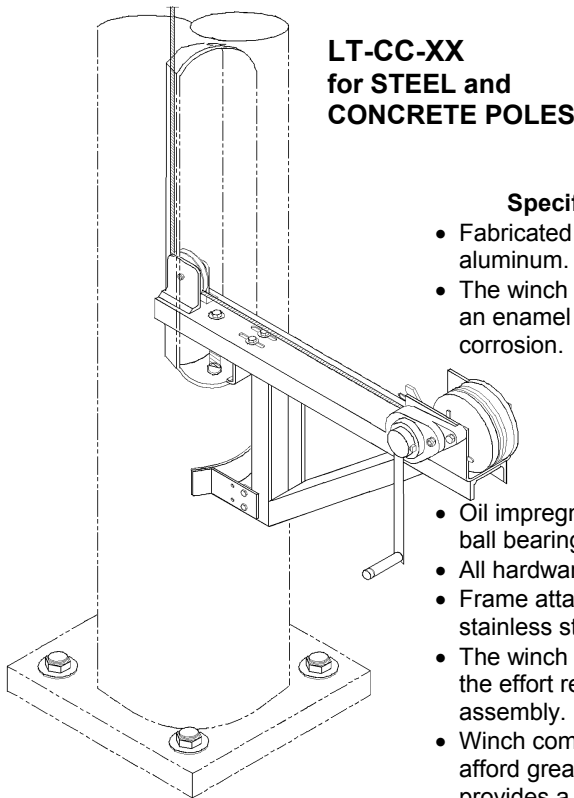

LT-CC-XX
for STEEL and
CONCRETE POLES

Specifications on Lowering Tool

- Fabricated from heavy gauge corrosive free aluminum.
- The winch has a primer base coat followed by an enamel finish coat. Excellent resistance to corrosion.
- Oil impregnated bronze bushings and sealed ball bearings.
- All hardware is made out of stainless steel.
- Frame attaches to pole handhole with 1/2" stainless steel bolt.
- The winch has a 3:1 Gear reduction to reduce the effort required to raise and lower the assembly.
- Winch comes with heavy-duty disk brake to afford greater load holding ability. This provides a positive locking mechanism to secure cable and keep from freewheeling.
- For drum capacity, see different models below.
- **Cable:** Equipped 5/32" 7x19 stainless steel aircraft cable.
- **Dimensions:** 29"L.x8"W. With handle, 12"W.
- **Weight:**34LBS.

LT-DRI-PWD

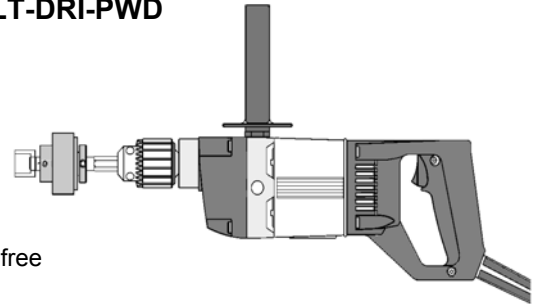

Drill Motor Specifications

- Drill is 1/2" double insulated, heavy duty, reversible, variable speeds, with 'D' handle.
- Chuck size is 1/2" key chuck with key.
- Electrical-Nom. 5 amp universal motor 115v.AC
- Torque-Develops nominal 170 lbs.-in.
- Speed/HP-.5 H.P. No load speed of 300 RPM
- Overall length is 15-1/8"
- Weight: Approx. 7lbs. 6oz.

Overload Clutch Specifications

- Lubricated ball indent-totally enclosed-adjustable torque limiting.
- Coil spring type. Varied quantities depending on torque range. Torque range: 60 to 300 lb./in.
- Winch drive is 1-1/8" hex socket with 1/2" sq. drive.
- Max. operating speed is 350 RPM
- Dimensions of clutch: 1 1/2"Dia., 1 5/8"L. Overall, 8 1/2"L
- Hub shaft: 3/8" sq. w/spring loaded pin (clutch end).
- Socket shaft: 3/8" sq. w/spring loaded retaining pin.
- Open-end wrench type torque-adjusting nut. Snap ring tool included with clutch.
- Clutch weight: 2 lbs.

Catalog # (with Lowering Tool cable length)	Min Load Lbs.	Cable Quantity	Max Load Lbs.
LT-CC-XX (cable length)	16	Up to 180FT	300
LT-DRI-PWD			

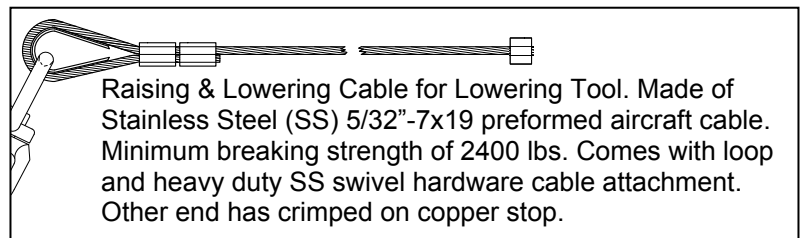

Raising & Lowering Cable for Lowering Tool. Made of Stainless Steel (SS) 5/32"-7x19 preformed aircraft cable. Minimum breaking strength of 2400 lbs. Comes with loop and heavy duty SS swivel hardware cable attachment. Other end has crimped on copper stop.

* All Lowering Systems gear boxes and lowering tools are designed for material handling usage only.
* Not for lifting people.
* Specifications subject to change without notice.