

Portable Winch Exposed Cable System with Portable Lowering Tool*

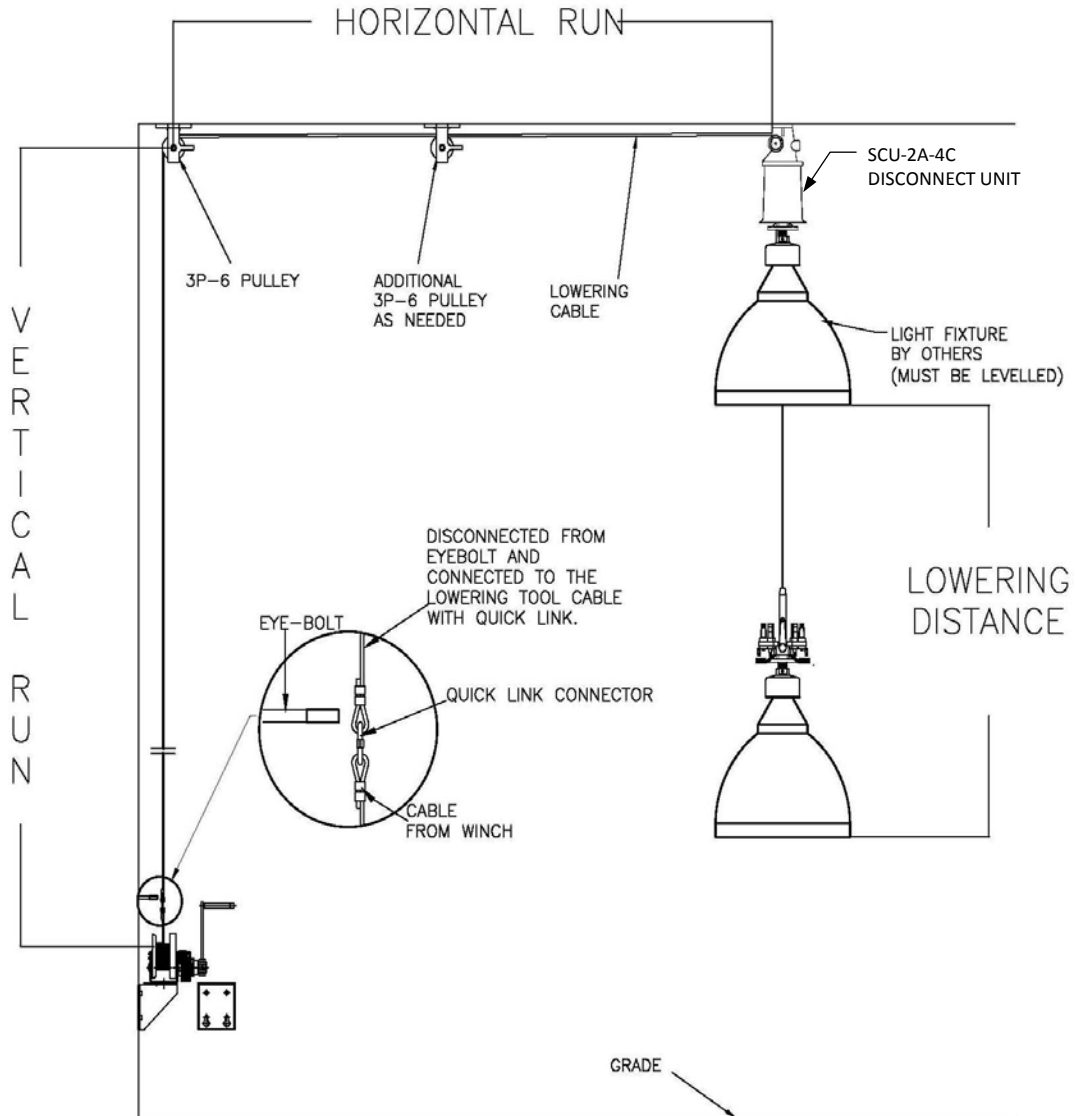

Details shown are intended as an application example only. Actual installation details may vary. Contact manufacturer's representative or factory for specific details about special installation application or other information. Lifting capacity is 400 lbs. and must not be exceeded.

The disconnect unit and pulleys must be mounted to a structure capable of supporting 5X the load of the fixture in the vertical and horizontal direction. Disconnect unit must be mounted to a support structure horizontally level on two 90 degree planes.

The system can be used with inclined ceilings provided the horizontal support for the disconnect unit fulfills all the requirements above. Leveling the mounting surface must be done by others.

*Tool Sold Separately

**Specifications subject to change without notice.



PWE-400-XXX

FOR FIXTURES WEIGHTING FROM 20 TO 400 LBS.

Principal Components of this system:

- 1. SCU-2A-4C Electrical Disconnect Unit Assembly:** It comes with four electrical contacts plus one ground as standard. (Additional contacts are available) and includes fittings for surface mounting to a horizontal structure and flange/stem adapter for mounting the disconnect unit to the fixture. This system can be used with inclined ceilings provided the horizontal support for disconnect unit fulfilling all the above mentioned requirements is provided by others.
- 2. LB-1 Locking Eyebolt:** Galvanized steel eyebolt used as a 'Parking stand' for the lowering cable when the fixture is in the raised (resting) position. The eyebolt is located on a wall at the termination point of the cable.
- 3. GA4407-XX Raising and Lowering Cable:** 5/32" dia. Galvanized Steel Aircraft Cable Assembly (Optional stainless steel cable). Total cable length required is calculated as: Horizontal Run + Vertical Run +5 ft.
- 4. 3P-6 Pulley:** A 3P-6 pulley will guide the cable at a desired angle. Optional extra 3P-6 pulleys (order separately) are available and must be used at every 30' of horizontal straight cable run and for every change in direction of the cable to a different plane. Optional 3P-7 pulleys (order separately) is available to guide cable around obstructions on the same plane.

Portable Lowering Tool:

GB-2P-XX Only one portable lowering tool is required per project (must be ordered separately). See lowering tool page for details of the GB-2P-XX.

Electrical Disconnect Unit (SCU-2A-4C) Specification Guide:

- ❖ All hardware shall be corrosion resistant stainless steel. It shall have a self-aligning and self-adjusting mechanical system comprised of two principal assemblies:
- ❖ The SCU-2A-4C cover shall be a one-piece hydro-spun heavy gauge aluminum.
- ❖ The top pulley housing shall be made of heavy-duty cast aluminum with a plated steel sheave with sintered bronze bearing. The top housing shall have a separate entrance for the electrical wire and a separate entrance for the lowering cable. The lowering cable shall pass through the center of the tracking post; travel on the sheave, and out the side of the housing shall have two mounting holes for top mounting.
- ❖ On the bottom of the SCU-2A shall consist of a heavy-duty cast aluminum flange with either a 3/4" external pipe thread or a 3/8" internal pipe thread to mount to the fixture, stem, or canopy. The electrical wires from the connector, travel through the center of the casting down to the fixture.
- ❖ The SCU-2A-4C shall consist of four contacts with max capacity of eight. The unit shall be UL & CUL Listed with a maximum usage rating of 15 Amp for 277/240/208 V. & 20 Amp for 120 V. per contact. 480V & 600V rating also available.
- ❖ All pulleys and Disconnect unit shall be mounted to a rigid, non moveable structure. It must not be able to move from side to side during the raising and lowering operation.

Specifications Guide

❖ The EDU shall have a 3-way tracking guide and support. It shall be constructed of precision cast high strength aluminum alloy 356-T6. A permanently fixed position piece incorporating a special tracking guide system permits the moveable portion of the *Disconnect Unit* to align in the same position every time the system is operated, thereby eliminating the need to re-orientate the fixture. The Electrical Disconnect Unit shall have twin high strength stainless steel locking cams securing the load of the *Lower Contact Assembly* and fixture. All tension on the cable is relieved when the fixture is in the raised position.

❖ The MULTI-CONTACT Connector assembly shall be modular for easy installation and retrofit requirements. The connector shall also have 4 size 12 contacts. Material of contacts shall be copper with nickel plating, and with gold plating over nickel per MIL-G-45204. Electrical contacts shall have a rating of 20 year mean time between failures. All hardware shall be corrosion resistant stainless steel. It shall have a self-aligning and self-adjusting mechanical system comprised of two principal assemblies:

The UPPER CONTACT HALF shall house the socket contacts. It shall incorporate spring assisted polymer contact body with precision-machined stainless steel guideposts. The socket contact body shall have integral guideposts for precise contact alignment.

The LOWER CONTACT HALF shall house the pin contacts comprised of spring assisted polymer contact body with precision-machined stainless steel guidepost receivers. The pin contact body aligns with guideposts of integral socket body guideposts.

❖ The wire leads are potted in Superflex® Black RTV Silicone, an industrial grade sealant for bonding and sealing.

❖ The unit shall have a guidepost constructed of precision cast high strength stainless steel. It shall utilize a cast-in-place guide bar for precise alignment of *Lower Contact Assembly* with the fixed portion of the *EDU*.

❖ The **EDU shall have** twin (2) tracking support arms made of precision cast high strength stainless steel. When locked in the *3-Way Tracking Guide and Support* notches, the *Twin Tracking/Support Arms* shall hold the weight of the fixture and components and it shall remove all tension from the *Control Cable or Lowering Cable*.

❖ The lower contact assembly shall be constructed of precision cast high strength aluminum alloy. It shall feature a cast-in-place guide that mate with the fixed portion of the *Disconnect Unit* to aid in tracking and stability. All hardware used on the *Lower Contact Assembly* as well as the entire *Disconnect Unit* shall be made of corrosion resistant stainless steel.

❖ The disconnect unit shall have a **HOUSING SEAL** made up of a spun aluminum closure ring with a sealing gasket constructed of extra flexible polymer providing a weather-tight seal between *Lower Contact Assembly* and *Disconnect Unit Cover*. This provides a flexible environmental seal. Seal swipes and conforms to interior of cylinder housing during all operating stages of the disconnect unit.

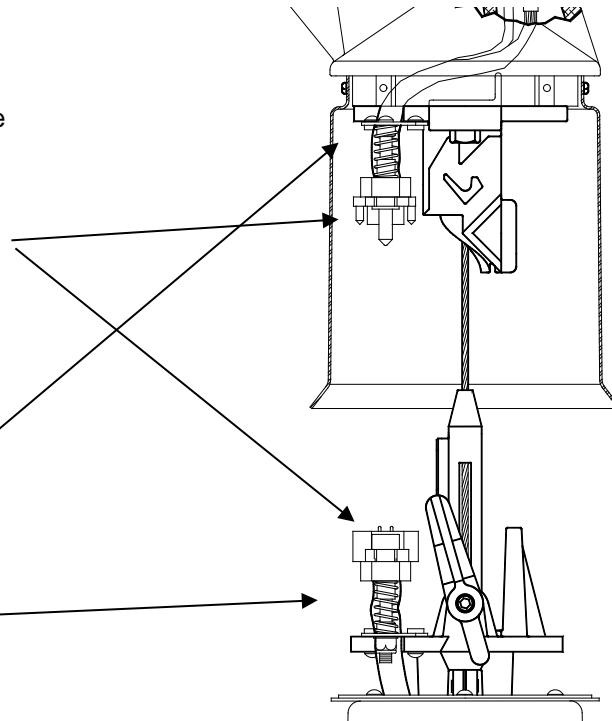

U.S. Patent No.
6,261,122



Electrical Contact Rating:

120V, 20 Amps per contact, (Multiple circuits)
240V/277V, 15 Amps per contact (Multiple circuits)
480V, 10 Amps (1 circuit max)
600V, 5 Amps (1 circuit max)

Mechanical Rating: 400 lbs with 6:1 safety factor
Weight: 8.5 LBS

SYSTEM DESIGNED SPECIFICALLY FOR USE WITH LIGHT FIXTURES, CAMERAS, AND RELATED EQUIPMENT ONLY.
NOT FOR LIFTING PEOPLE OR THINGS OVER PEOPLE.
SPECIFICATIONS SUBJECT TO CHANGE WITHOUT NOTICE.

Specifications Guide

Frontal View



Side View

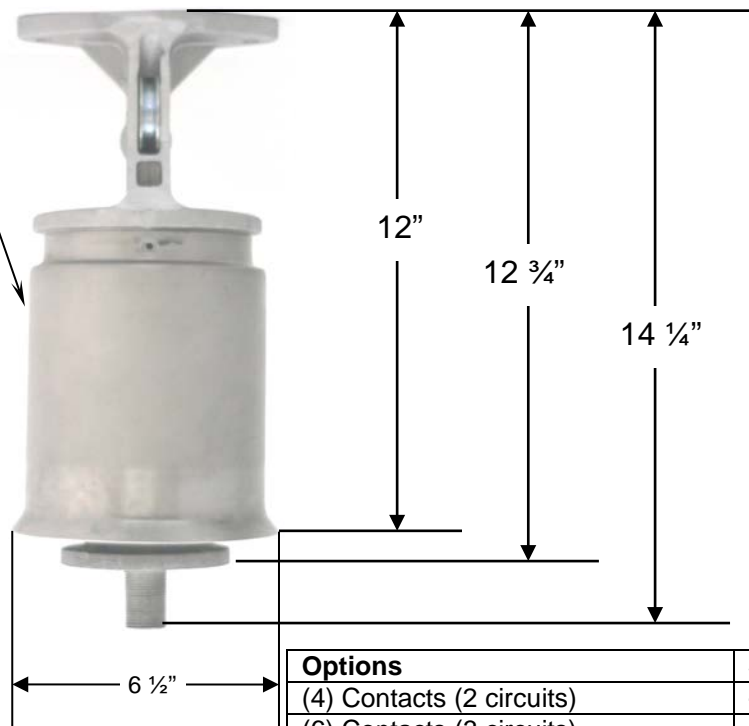
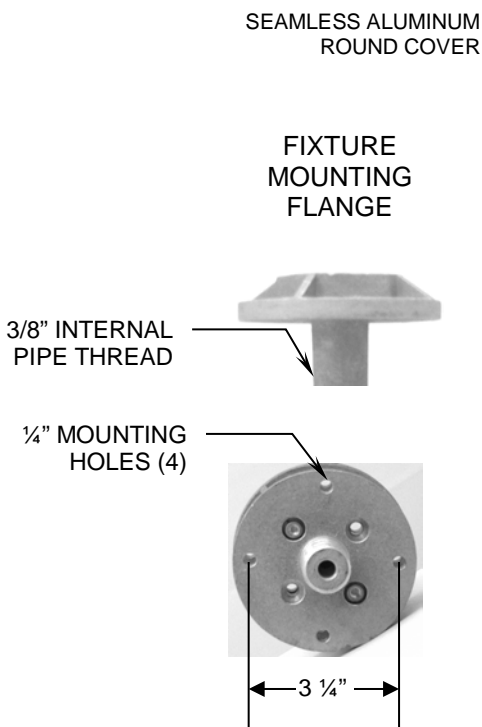
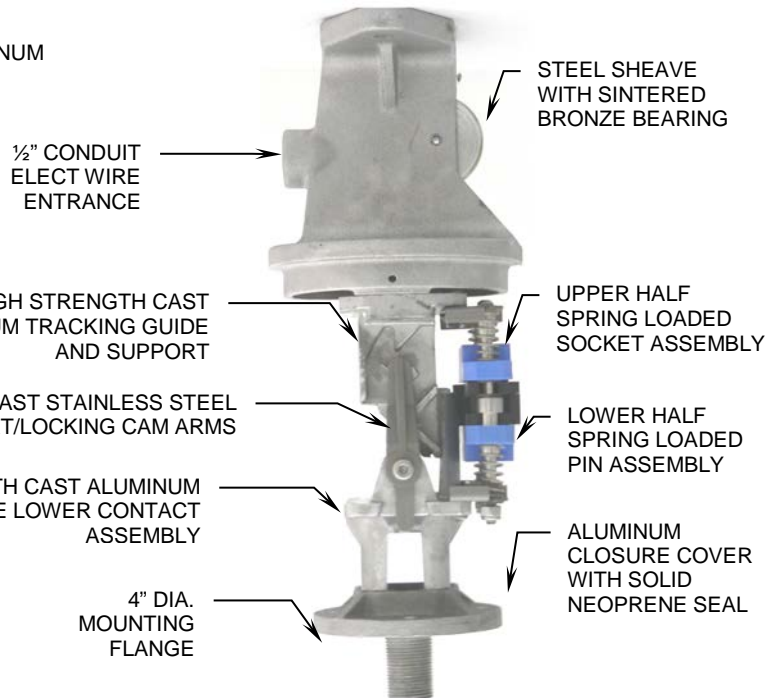

Options	Suffix
(4) Contacts (2 circuits)	-4C
(6) Contacts (3 circuits)	-6C
(8) Contacts (4 circuits)	-8C
3/8" Internal Pipe Thread Mounting	-38
Other mounting-consult factory	

Cable Orientation Options:

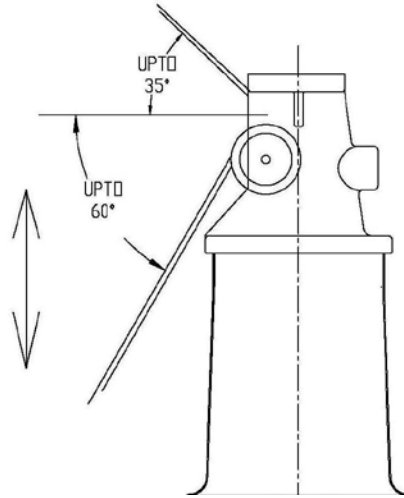

The disconnect unit allows the cable path orientation at an angle. The pulley installed in the upper casting attached to the disconnect unit guides the cable in the required orientation.

Mounting Details:

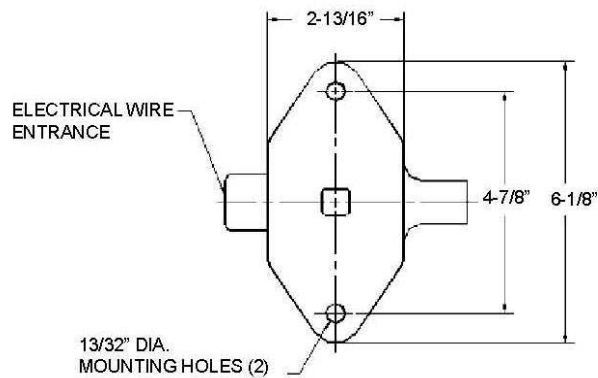

The disconnect unit must be mounted on rigid horizontal support. This support must be approved by others to be able to withstand static and dynamic loading of at least 5 X the weight of the fixture in all directions. Square center hole is optional. Please specify if required at the time of ordering.

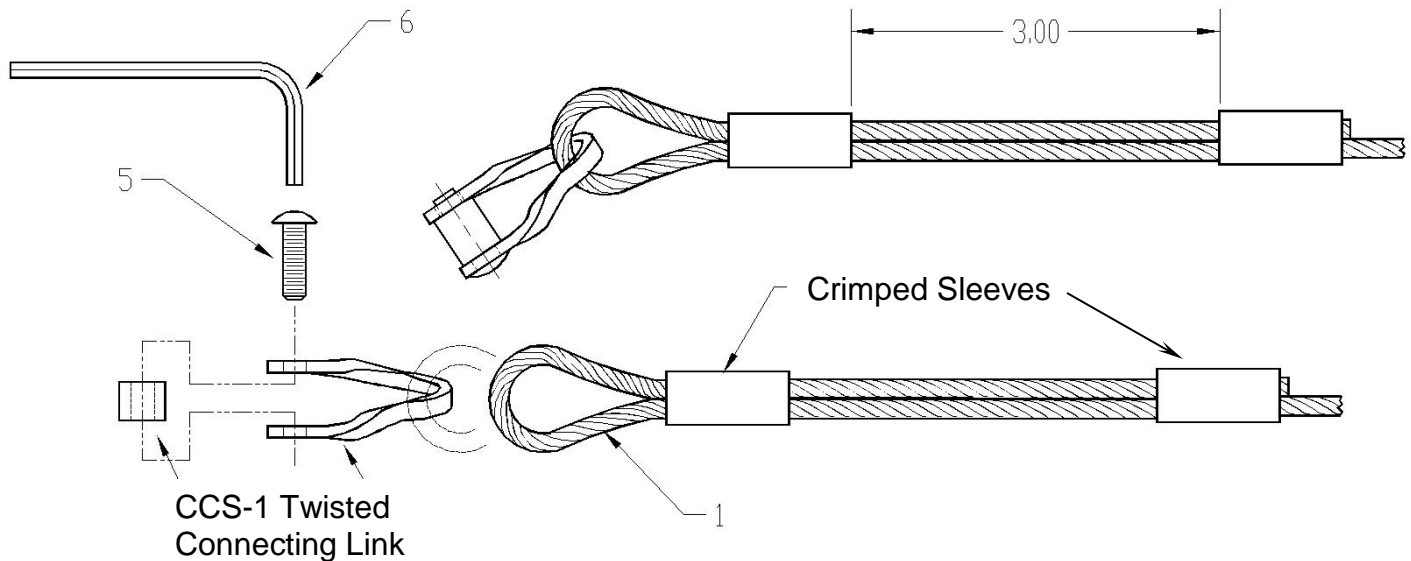
Specification Guide for Other Components:

GA4407-XX
Raising & Lowering (Control) Cable Assembly

- ❖ The system shall utilize a CONTROL CABLE (mechanical raising and lowering cable) made of galvanized steel 5/32 inch diameter 7 x 19 construction cable. One end of the cable shall have a heavy duty stainless steel connector link (Optional Stainless Steel cable for very corrosive environments) with 2 sleeves crimped onto the cable. The raising and lowering (control) cable shall be made of galvanized/stainless steel 5/32-inch diameter 7 x 19 construction. Minimum breaking strength shall be 2400 lbs.
- ❖ A GB-2P LOWERING TOOL (only 1 needed per order) shall be supplied with each order. It is a lowering tool consisting of the gearbox, disc brake, frame and lowering cable. The gear box shall be of heavy duty design to provide reliability, long life, and ease of operation. It incorporates solid steel heat treated gears for maximum durability and strength. It is equipped with a special automatically actuated disc brake for load holding ability and the prevention of the load free wheeling. It shall have a corrosive resistant finish.
- ❖ Various types of pulleys are available and should be designed for the exact load and gearbox. All pulleys shall have oilite bronze bearings for maintenance free life. This also insures their use for dirty atmosphere applications. Painted pulleys are available for highly corrosive areas. Pulleys are required when vertical or horizontal changes in direction occur. Five types are available for various mounting and load requirements. It is important that pulleys are properly aligned when installing and always take pulley friction into consideration if loads are near the limits.
- ❖ PB-1 pulley box (optional) for use instead of a 3P-6 pulley assembly. The PB-1 allows conduit to be connected to the pulley box. It shall be mounted for cable turns of 90 degrees when it becomes necessary for the lowering cable to always run inside a conduit (dirty atmospheric conditions, exposure to extreme conditions).

Other system is also available for fixture weighing above 400 lbs. Contact factory for details.

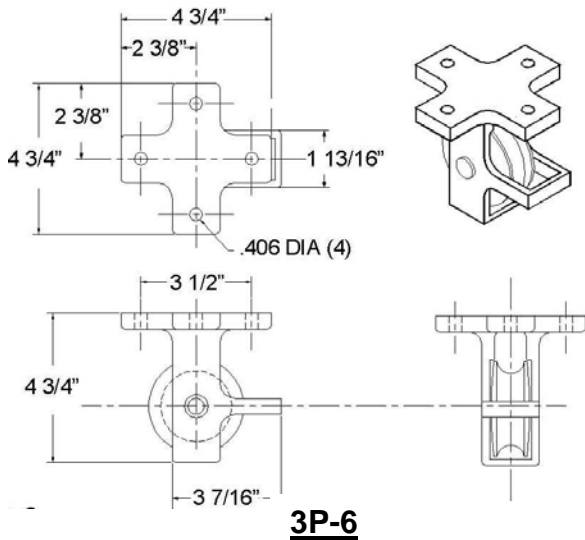
Various types of pulleys are available and should be designed for exact load and gear box. All pulleys have oilite bronze bearings for maintenance free life. This also insures their use for dirty atmosphere applications. Painted pulleys are available for highly corrosive areas. Pulleys can be spaced 6-30' apart on horizontal runs. A pulley must be used at every 30' of horizontal straight runs. Pulleys are required when vertical or horizontal changes in direction occur. It is important that pulleys are properly aligned. The centerline of the pulley-sheave groove must coincide with the centerline of the cable path when installing. Always take pulley friction into consideration if loads are near limits of the gear box. Pulleys must be installed on rigid surfaces which are able to withstand at least 5 X load of the fixture in all directions. The installation must be approved by others.



3P-6

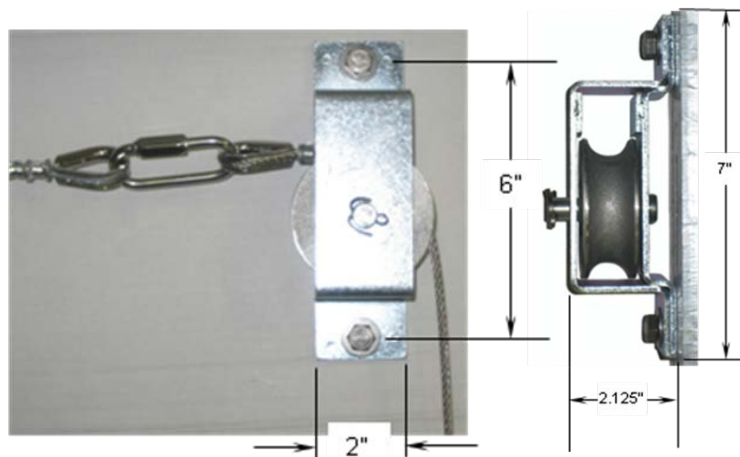

3P-7

3P-6

Load capacity for a 3P-6 pulley is 20-400 lbs. A 3P-6 pulley can facilitate a change in direction of the cable from wall to ceiling i.e. from vertical to horizontal. 3P-6 pulleys should be spaced 6-30' apart on horizontal runs. Change in direction of cable to angles other than 90 degrees is possible. See page p3 for details. This pulley allows the twisted quick-link to pass through.

3P-7

A 3P-7 pulley can facilitate a change in direction of the cable on the same plane i.e. on the ceiling or on the wall. The pulley allows the cable connecting link to pass through.

Load capacity: Up to 400 lb. fixtures.

Frame Material: Frame material of zinc plated 7gge. Steel.

Frame Material Option: Stainless steel frame. Contact factory.

Sheave Material: Sheave of cast aluminum with oilite bronze bearing.

Mounting: Two mounting holes for 3/8" bolts. Hardware by others. Type of hardware depends on the type of structure that the pulley is mounted to. Structure must not move while the system is in operation.

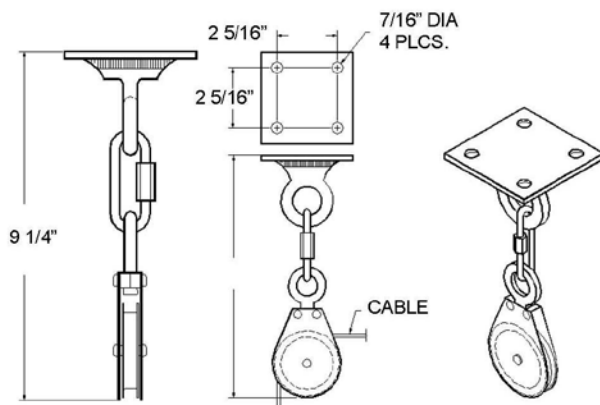

3P-5

3P-5

Load capacity for a 3P-5 pulley is 20-400 lbs. A 3P-5 pulley can facilitate a change in direction of the cable in different planes by utilizing the swivel.

* Specifications subject to change without notice.

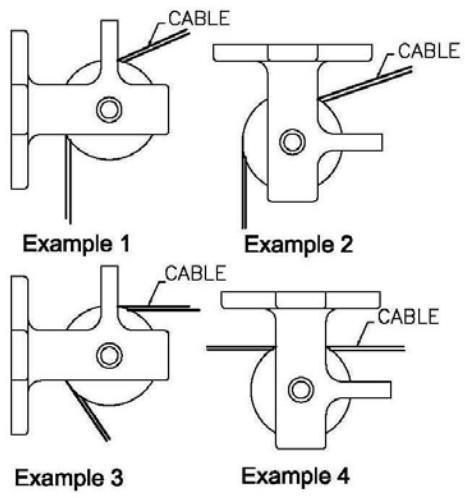

3P-6 and 4P-4 Uses

3P-6 and 4P-4 pulleys (depending upon load) can facilitate a change in direction of the cable from wall to ceiling i.e. from vertical to horizontal. These pulleys should be spaced 6-30' apart on horizontal runs. The above examples show that change in direction of cable to angles other than 90 degrees is possible. These pulleys can be placed horizontally (examples 2 and 4), vertically (examples 1 and 3) and on inclined surfaces for maximum versatility as long as the cable path is aligned to the pulley sheave groove and as long as the cable path is not interfered by any obstacles.

MAXIMUM FIXTURE LOAD

400 LBS	3P-6
1100 LBS	4P-4

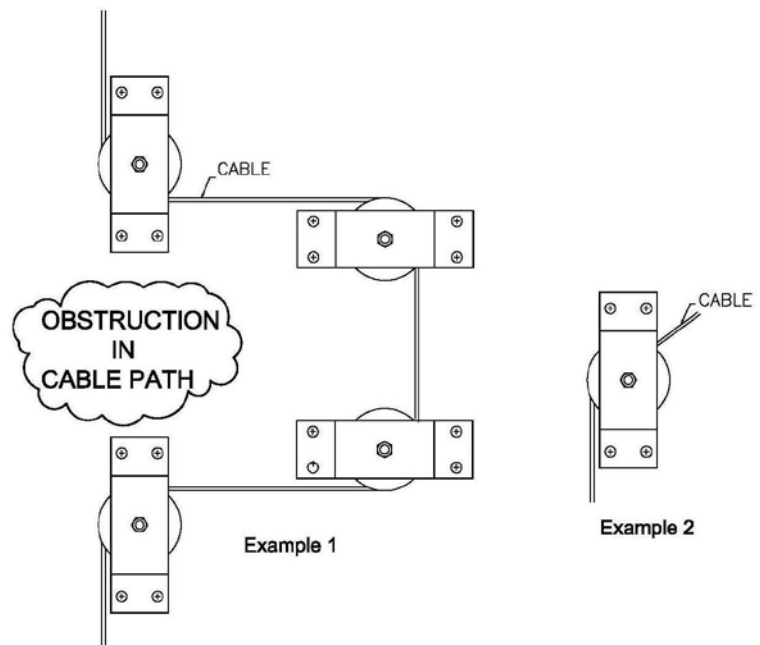

3P-7 and 4P-3 Uses

3P-7 and 4P-3 pulleys (depending upon load) can facilitate a change in direction of the cable on the same plane. Example 1 is a simple way using 4 pulleys to go around an obstruction in the cable path. In example 2, the pulley allows the cable to change direction on the same plane.

MAXIMUM FIXTURE LOAD

400 LBS	3P-7
1100 LBS	4P-3

* Specifications subject to change without notice. Details shown are intended as an application example only. Actual installation details may vary. Contact manufacturer's representative or factory for specific details about special installation application or other information. Lifting capacity is 400 lbs and must not be exceeded.

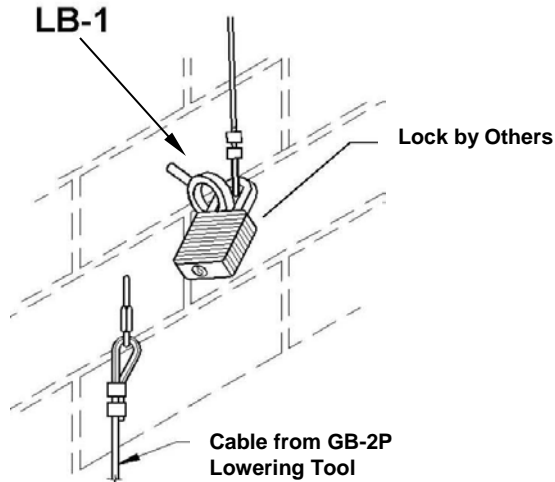

TERMINATION SYSTEM

Locking Bolt **LB-1**

- Each lowering cable must be terminated in a locking system.
- Two types are available to prevent unauthorized personnel from lowering the fixtures.
- If the lowering cable is mounted indoors and a security locking box is not required, the locking bolt **LB-1** design should be used.
- The **LB-1** is a steel eye bolt with a Galvanized finish.
- Cable should be attached to the eyebolt when the cable is not being used to raise and lower the fixture.
- The cable should be locked (lock by others) to the eyebolt, if security is an issue, or the **SLB-3** should be used (see **ECS** system specs).

All gear boxes and lowering tools are of heavy duty design to provide reliability, long life, and ease of operation. They incorporate heat treated gears for maximum durability and strength. All are equipped with a special automatically actuated disc brake for better load holding ability and the prevention of the load free wheeling. They are available for permanent installation or portable use indoors or outdoors for wall mounting or pole mounting. Each system is custom tailored to work with required load and operation for the raising/lowering specifications. "L" shaped mounting bracket is made of heavy duty steel with a primed coated finish.



GB-2P's grouped together to save space.

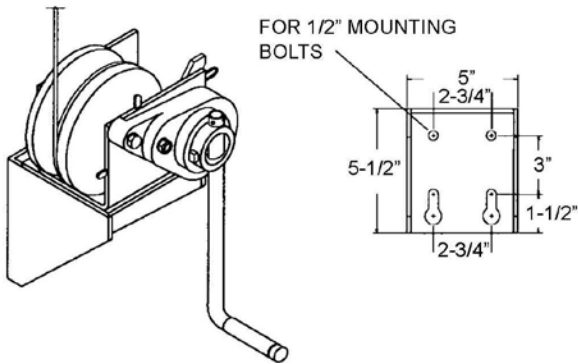
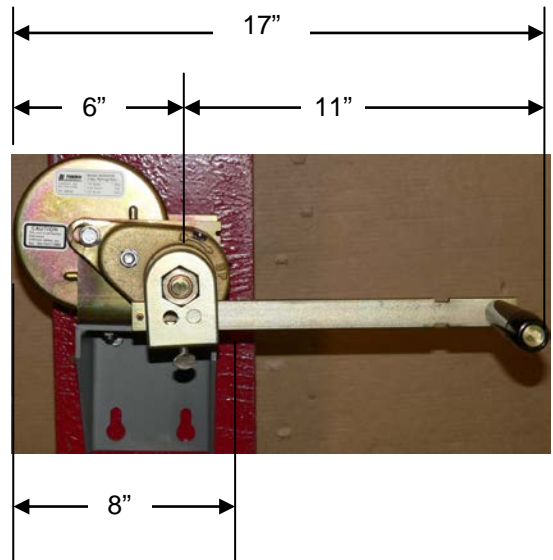

CATALOG # GB-2P
PERMANENT OR PORTABLE
WALL MOUNTED GEAR BOX FOR
FIXTURES UP TO 400 LBS.

CAT. #	MIN. LOAD LBS	DRUM CAPACITY	WEIGHT LBS.
GB-2P	16	90 FT.	20
GB-2PA	16	180 FT.	22

- ◆ All Lighting & Lowering Systems gear boxes and lowering tools are designed for material handling usage only.
- ◆ Galvanized Steel 7x19, 1/8" Dia Aircraft Lowering Cable.
- ◆ Cable length: Per required.
- ◆ Not for lifting people or things over people.
- ◆ Specifications subject to change without notice.

