



Installation & Operation Manual MLS-XXX-TH8

Lighting and Lowering Systems®



Table of Contents

Table of Contents.....	ii
Purpose of This Manual.....	1
Definitions and Abbreviations.....	2
Company Description.....	3
Chapter 1 Installation.....	4
1.1 Mounting the Disconnect unit.....	5, 6
1.2 Mounting the Motor Assembly.....	7-12
1.3 Wire rope Installation.....	13
1.4 Wiring Diagram.....	14
1.6 Cable clamp assembly.....	15, 16
1.7 Canopy installation.....	17, 18, 19
Chapter 2 Testing.....	20
2.1 Programming the lowering distance for the first time.....	20-23
Chapter 3 Programming.....	24
3.1 Programming or Reprogramming the Lowering distance.....	24, 25
Chapter 4 Operation.....	26
4.1 Operating Instructions for the Control Panel.....	26, 27
4.2 Features of the Control Panel.....	28
4.3 Alternate Conditions.....	28
4.3.1 Alternate Conditions when programming the system for the first time.....	28
4.3.2 Programming for lowering distance in excess of 25 ft.....	29
4.4 FAQ.....	30

Purpose of This Manual

At Lighting & Lowering Systems and Camera Lowering Systems, products are designed to make installation easy and operation uncomplicated. The product will give outstanding service when properly installed according to the instructions and operated according to the guidelines provided in this manual.

The purpose of this manual is to serve as a “road-map” for the user to the installation, and operation of the MLS-XXX-TH8. In addition to that, the purpose of this manual is also to guide the user in cases of emergency and operation of the system.

Please take utmost care in installing the system. It is very important that all units are mounted on rigid supports and level surfaces and the installation is approved by a structural engineer. It is also very important to read all the instructions before installing, programming and operating the system.

If you have any questions or suggestions, please contact technician at [708-681-4330](tel:708-681-4330).

WARNING

- **EXCEPT WHEN TESTING, PROGRAMMING AND OPERATION, NEVER LEAVE THE SYSTEM IN ANY OTHER THAN LOCKED POSITION.**
- **DO NOT LEAVE THE SYSTEM UNATTENDED WHEN NOT IN LOCKED POSITION.**
- **DO NOT LIFT PEOPLE OR OPERATE ANY LOWERING SYSTEM OVER PEOPLE.**
- **THIS SYSTEM IS USED TO RAISE AND LOWER FIXTURES A MAXIMUM OF 60FT.**
- **THERE MUST NOT BE ANY INTERFERENCE OF THE RAISING AND LOWERING CABLE. PULLEYS SHOULD BE USED FOR CHANGE OF DIRECTION.**
- **ALWAYS WATCH THE FIXTURE DURING THE RAISE AND LOWER OPERATION.**
- **FIXTURE MUST BE CONNECTED TO THE DISCONNECT UNIT WITH A MINIMUM OF 4 CHAINLINKS OR QUICK LINKS.**
- **THE FIXTURE AND DISCONNECT UNIT MUST BE LEVEL ON X AND Y AXIS.**
- **THE DISCONNECT UNIT MUST BE MOUNTED TO A RIGID NON-MOVEABLE STRUCTURE, AND LEVEL ON X AND Y AXIS.**
- **MOTOR ASSEMBLY MUST BE MOUNTED 12FT OR GREATER FROM THE NEAREST PULLEY OR DISCONNECT UNIT.**
- **READ COMPLETE MANUAL BEFORE ATTEMPTING. CONTACT FACTORY FOR CLEARIFICATION, EXPLAINATIONS, AND COMMENTS.**



Definitions and Abbreviations

MLS Motorized Lowering System

GAXXXX_(cable length) Cable (depending upon application)

TH8 Motor for the MLS

CP-2 Control Panel

For **MLS-400-TH8** (up to 400 lbs.)

SCU-2A-MS Suspended Contact Unit (Disconnect Unit) with Micro Switch (up to 400 lbs.)

CAN-8-65 Brass Canopy Option Spring loaded Canopy (up to 400 lbs.)

For **MLS-600-TH8** (401 to 600 lbs.)

SCU-2X Suspended Contact Unit (Disconnect Unit) with Micro Switch (over 400 lbs.)

CAN-12-65 Brass Canopy Option Spring loaded Canopy (over 400 lbs.)

For **MLS-1100-TH8** (601 to 1100 lbs.)

SCU-2X Suspended Contact Unit (Disconnect Unit) with Micro Switch (over 400 lbs.)

CAN-12-65 Brass Canopy Option Spring loaded Canopy (over 400 lbs.)

Note: Canopy is optional.



Company Description: North Star Lighting Inc.

Though it's easy to tell North Star's product story, we prefer to let our customers speak for our ability to deliver outstanding results. What is important here is North Star's long standing reputation for providing a comprehensive, highly energy efficient family of HID (high intensity discharge) products, and meeting our customer's precise performance and price requirements for Lighting Systems which include Sports lighting, Commercial lighting, and Architectural and Thorn lighting and for Lowering Systems for Cameras, Lights, Speakers etc.

Lighting & Lowering Systems ♦ Camera Lowering Systems

Lowering Systems, a division of North Star Lighting Inc., has experience in lowering systems dating back to 1967. Our engineering and marketing know how has been a major force in the industry starting with our pioneering efforts in the development of the first raising and lowering High Mast system in the United States.

Realizing the need for this type of maintenance we have perfected new lowering systems for indoor and outdoor applications at reduced cost; at the same time keeping the system simple and safer for maintenance people to operate.

Lowering devices offer three major features

- Safety
- Simplicity
- Value

New lowering systems offer fast, safe and easy maintenance of cameras and other devices in high or inaccessible areas. All servicing is done at ground level. Hazardous and time consuming high lift truck maintenance is eliminated. The efficiency of the higher mounting height need not present a problem in servicing the equipment. The use of high mounting height results in fewer cameras. This in turn results in reduced installation costs and less power usage. This savings offsets the cost of the lowering system. Cameras and other devices are lowered individually eliminating the need to lower massive lowering units which are complicated, expensive and heavy.



Installation

MLS-XXX-TH8 System is designed to make installation and set-up as straightforward as possible and will provide excellent service when properly installed in accordance with the following instructions.

1.1 Mounting the motor/winch platform

IMPORTANT

The lowering cable should not touch or interfere with the motor platform during the system operation for any of the mounting patterns.

Four .41" diameter holes are provided for mounting the motor assembly. The fastener type and size required will vary according to the type of mounting surface but **must be adequate to safely sustain all loads, including horizontal pull**. The structural engineer for the building should be consulted to determine the proper method and size of the fastener necessary. The platform may be mounted in four orientations (see page 8).

1.2 Mounting the SCU Disconnect Unit

IMPORTANT

The SCU unit must be mounted on a rigid beam or a rigid suspended platform, which is made with heavy angle iron, extrusion etc. Please see figure 1.2.1.

See mounting dimensions for the SCU-2X and SCU-2A disconnect units figure 1.1.1 on Page 5.

The lowering (moveable) portion of the disconnect unit should be checked for lubrication at least once a year.

1.3 Wiring

One conduit should run from the disconnect unit to the connection box on the motor platform. Another conduit must run from the motor connection box to the CP-2 control panel (see wiring diagram provided). Wire leads are color coded to prevent wiring incorrectly. Wires from the disconnect unit to the motor to the control panel must be provided by the contractor. Use appropriate size wire to prevent voltage loss and excessive heat (check local electrical codes). See figure 1.3.1.

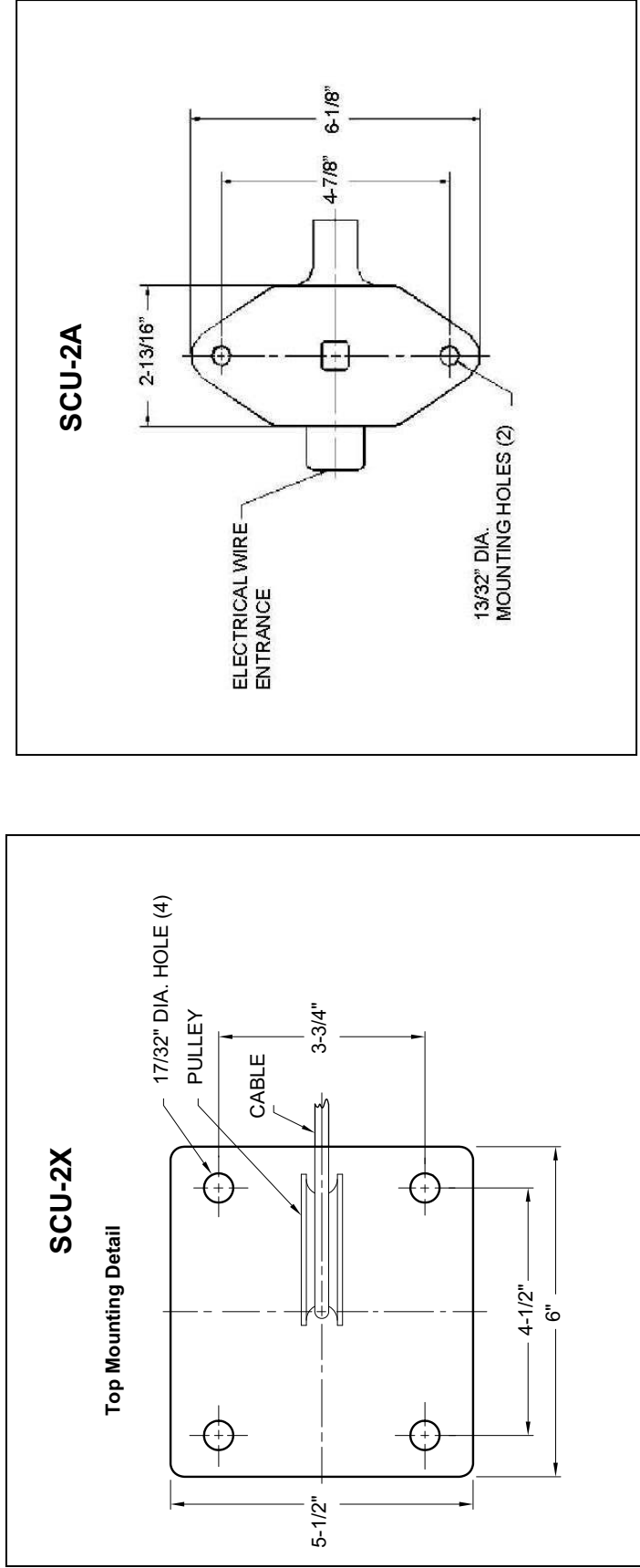
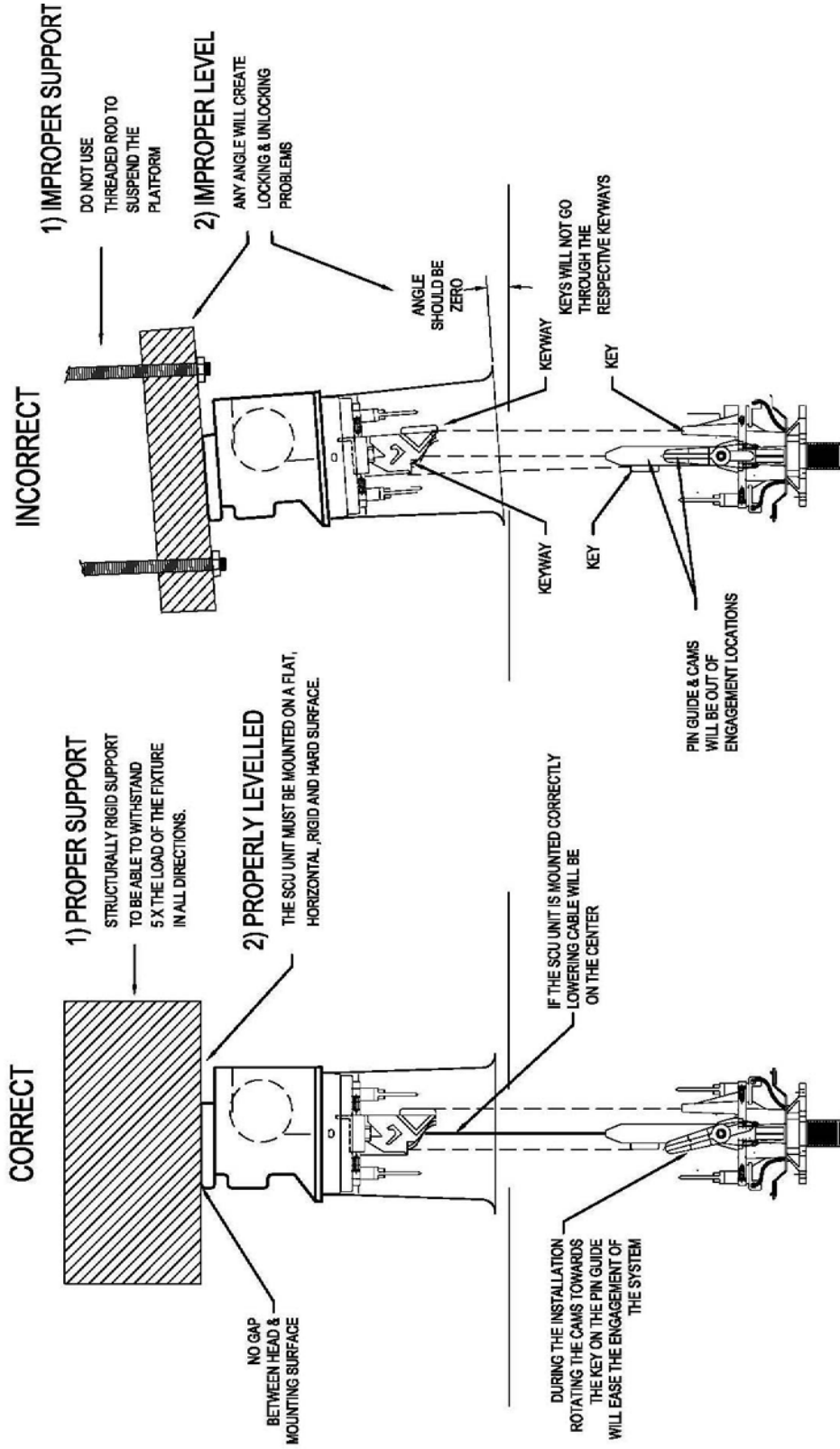
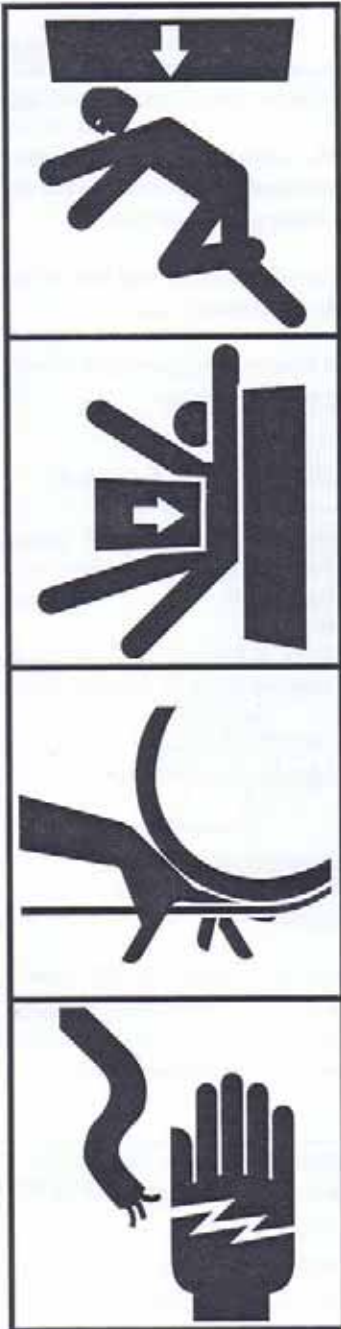

Figure 1.1.1 Mounting the disconnect unit

IMPORTANT



Suggestions for Safe Operation



⚠WARNING

DO the following:

Read and comply with the guidelines set forth in this Owner's Manual. Keep this manual, and all labels attached to the winch, readable and with the equipment at all times. Contact Thern, Inc. for replacements.

Check lubrication before use.

Install the wire rope securely to the winch drum.

Keep at least 4 wraps of wire rope wound on the drum at all times, to serve as anchor wraps. With less than 4 wraps on the drum the wire rope could come loose, causing the load to escape.

Keep hands away from the drum, wire rope, and other moving parts of the equipment.

Keep all unnecessary personnel away from winch while in operation. Keep out of the path of the load and out of the path of a broken wire rope that might snap back and cause injury.

Disconnect power before servicing the equipment.

DO NOT do the following:

Do not lift people, or things over people. Do not walk or work under a load or in the line of force of any load.

Do not use clutch equipped models to lift loads, or drag loads on an incline. Accidental release of the clutch could result in loss of the load.

Do not exceed the load rating of the winch or any other component in the system. To do so could result in failure of the equipment.

Do not use more than one winch to move a load unless each winch was designed for use in a multiple winch system.

Do not use damaged or malfunctioning equipment. To do so could result in failure of the equipment.

Do not modify the equipment in any way. To do so could cause equipment failure.

Do not wrap the wire rope around the load. This damages the wire rope and could cause the load to escape. Use approved rigging connectors to secure the wire rope to the load.

Do not lift loads or pull loads on an incline unless the winch is equipped with a load brake.

Do not divert your attention from the operation. Stay alert to the possibility of accidents, and try to prevent them from happening.

Do not jerk or swing the load. Avoid shock loads by starting and stopping the load smoothly. Shock loads overload the equipment and may cause damage.

Do not leave a suspended load unattended unless specific precautions have been taken to secure the load and keep people away from the winch and out from under the load.

Do not adjust the brake with the load suspended.

Do not exceed the 15 minute duty cycle rating of the winch. To do so could result in equipment damage or failure.

IMPORTANT:

Study all applicable codes, manuals, and regulations. Be sure to read the Installation and Operations Guide before installing and operating.

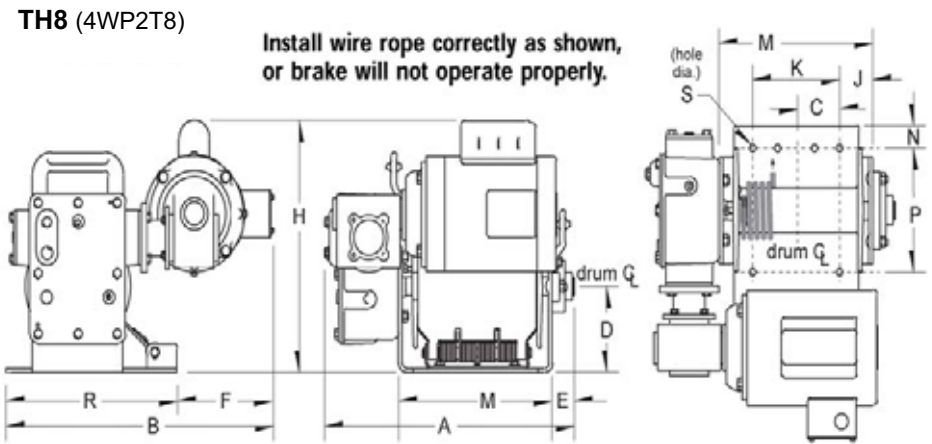
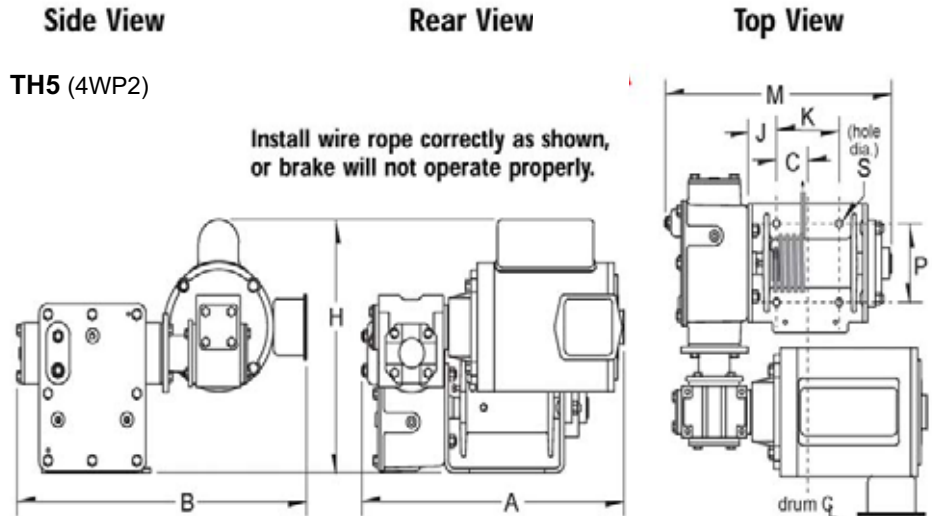

Dimensions for the TH5 and TH8 assemblies (in)

Model	A	B	C	D	E	F	H	J	K	M	N	P	R	S (hole dia.)
TH5	15.63	17.28	1.72	3.50	1.375	9.00	12.84	1.72	3.75	13.50	1.00	4.00	6.50	.41
TH8	15.62	17.80	2.75	4.88	1.44	6.43	14.25	2.25	5.81	10.25	1.25	7.00	11.38	.41

Dimensions are for reference only and subject to change without notice.

Specifications are subject to change without notice.

1.1 Installing the Winch

▲WARNING

Do not install the winch in an area defined as hazardous by the National Electric Code, unless installation in such an area has been thoroughly approved.

Do not install the winch near corrosive chemicals, flammable materials, explosives, or other elements that may damage the winch or injure the operator. Adequately protect the winch and the operator from such elements.

Position the winch so the operator can stand clear of the load, and out of the path of a broken wire rope that could snap back and cause injury.

Attach the winch to a rigid and level foundation that will support the winch and its load under all load conditions, including shock loading.

Important!

- Inspect the winch immediately following installation according to the Instructions for Periodic Inspection. This will give you a record of the condition of the winch with which to compare future inspections.
- A qualified professional should inspect or design the foundation to insure that it will provide adequate support.
- Locate the winch so it will be visible during the entire operation.
- Do not weld the winch frame to the foundation or support structure. Welding the frame may void warranty, contact Thern, Inc. Use fasteners as instructed.

- 1.1.1 CONSULT APPLICABLE CODES AND REGULATIONS for specific rules on installing the equipment.
- 1.1.2 LOCATE THE WINCH in an area clear of traffic and obstacles. Make sure the winch is accessible for maintenance and operation.
- 1.1.3 LOCATE THE WINCH in an area with adequate temperatures. The winch is rated for operation in ambient temperatures ranging from 0° to 100° F.
- 1.1.4 MAINTAIN A FLEET ANGLE between 1/2 and 1-1/2 degrees. The proper fleet angle minimizes wire rope damage by helping the wire rope wind uniformly onto the drum. See Figure 2.
- 1.1.5 POSITION THE WINCH to allow access for proper lubrication.
- 1.1.6 FASTEN THE WINCH securely to the foundation.
 - a FOR STANDARD PRODUCTS referred to in this manual, use 3/8 - inch coarse thread fasteners, grade 5 or better, torque dry to 30 ft lb without lubrication. Make sure the winch is secured to a solid foundation able to support the winch and the load under all conditions with design factors based on accepted engineering practices.
 - b NON-STANDARD PRODUCTS that vary from the original design may have different fastening requirements. Contact a structural engineer or Thern, Inc. for this information.

TO COMPLY WITH LOCAL CODES, CONTACT A QUALIFIED PROFESSIONAL TO OBTAIN PROPER STRUCTURE OR FOUNDATION SPECIFICATIONS FOR THE MOUNTING OF THERN PRODUCTS.

1.2 Installing the Breather Plug

Important!

- Save the extra oil plug for use when the winch is removed for storage or transport.

CAUTION

Install the breather plug to vent heat and pressure from the gearbox. Failure to do so could result in pressure buildup which can cause the gearbox to leak or damage the equipment.

For shipment, the gearbox is sealed with an oil plug, and the breather plug is attached to the gearbox or shipped in a separate envelope.

- 1.2.1 REMOVE THE OIL PLUG and install the breather plug in the proper location. Make sure the breather plug is above the level of the oil. See Figure 1.
- 1.2.2 CHECK THE OIL LEVEL in the gearbox to make sure no oil was lost during shipment. See section 3.3 Lubricating the Winch.

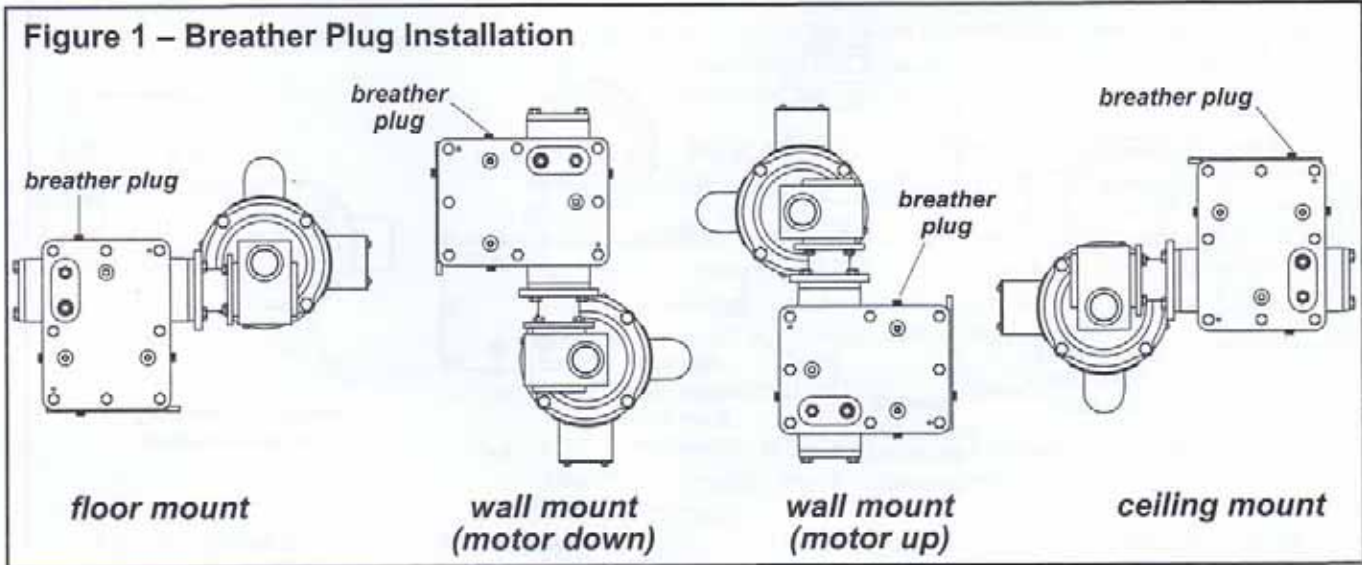

Important!

- Use a sheave or roller guide to direct the wire rope to the drum whenever possible.
- Install sheaves, tracks and other equipment so they will remain fixed under all load conditions. Follow the recommendations of the equipment manufacturer.
- Use sheaves of proper diameter to minimize wear on the wire rope. Follow the recommendations of the sheave manufacturer.

Figure 2 – Maintaining the Fleet Angle

When wire rope travels over a sheave or through a roller guide – maintain fleet angle by locating the sheave or guide an appropriate distance from the drum, shown as distance "A".

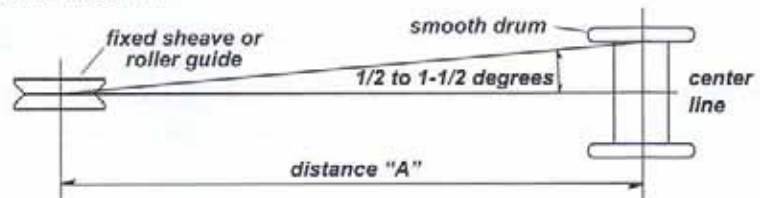

When wire rope travels directly to the load – maintain fleet angle by controlling side-to-side movement of the load with tracks or guide rails. Allowing the load to move too far to one side causes stress on the drum flange which may cause damage.

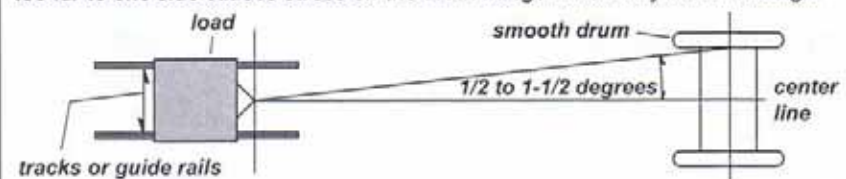

1.3 Removing Motor Drain Plugs

Some electric motors are equipped with screw plugs which are designed to be removed to provide drain holes.

- 1.3.1 LOCATE THE LOWEST POINT ON THE ELECTRIC MOTOR.
- 1.3.2 REMOVE THE SCREW PLUG located at this lowest point. See Figure 3.

Figure 3 – Motor Drain Plug Removal

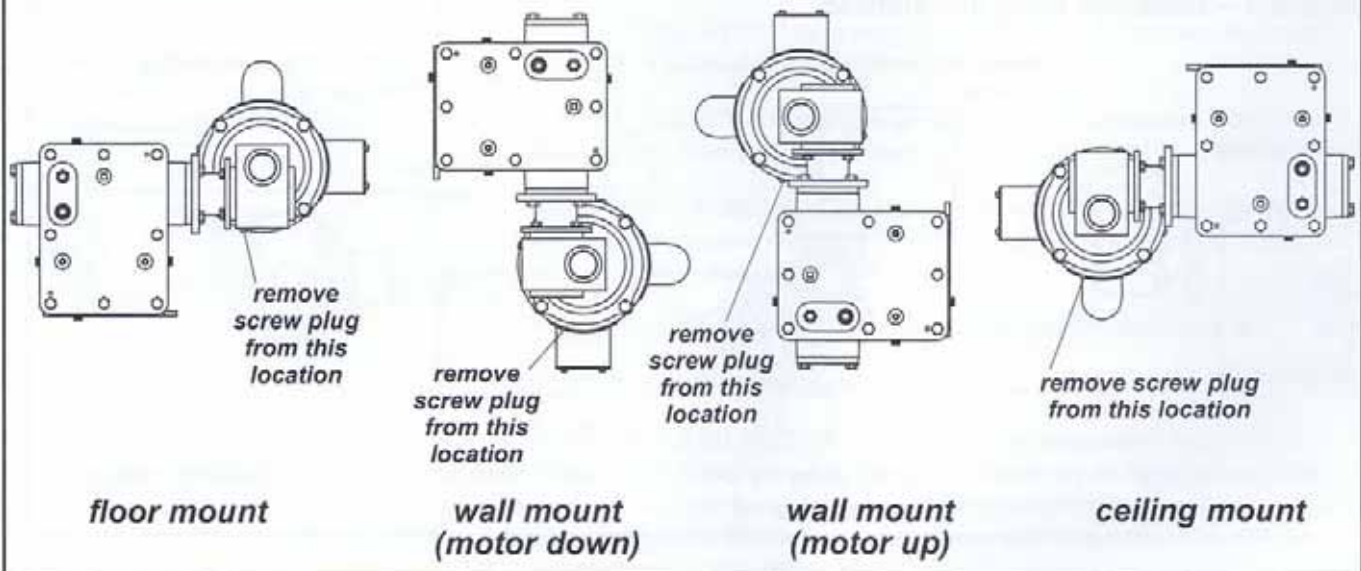

1.4 Connecting Power

Important!

- Use components rated for the power supply you will be using.
- Always disconnect power when the winch is not in use.

⚠WARNING

Install proper branch circuits, disconnect devices, protection, and grounding as required by article 430 of the National Electric Code.

All electrical work must be performed by a licensed electrician. Failure to do so could result in electric shock or poor winch operation.

All control devices must be momentary contact type. Install all control devices so the winch motor will stop when the operator releases the device.

Locate control devices so the operator will be able to view the load through the entire operation.

Locate control devices so the operator will be clear of the load, the wire rope, and the path of a broken wire rope that could snap back and cause injury.

It is the responsibility of the owner to provide equipment for controlling the winch. Controls are available from Them. The following guidelines are supplied as a reference for the installer.

- 1.4.1 **CONSULT APPLICABLE CODES AND REGULATIONS** for specific instructions regarding power supply installation and hookup.
- 1.4.2 **FOR ELECTRIC WINCHES:** install a fuse or circuit breaker, and a disconnect device in the power supply circuit, as required by the National Electric Code. The disconnect device should be a switch you can lock in the OFF position to prevent unauthorized use of the winch.
- 1.4.3 **CONNECT THE POWER CORD** to a grounded outlet.
- 1.4.4 **FOR PNEUMATIC WINCHES:** install a regulator, filter, lubricator and drier in the air supply line. Failure to operate with clean, dry, lubricated air will void warranty.
- 1.4.5 **FOR HYDRAULIC WINCHES:** install a filter in the hydraulic supply line. **Use Mobil DTE hydraulic fluid, or equal, with a viscosity range of 100 – 200 SUS.**
- 1.4.6 **INSTALL A CONTROL DEVICE** in the power supply line and connect power to the motor. Make sure the control device is a momentary contact type so the motor will stop when the operator releases the control.
- 1.4.7 **CONNECT OTHER EQUIPMENT** to the power supply as necessary.
- 1.4.8 **CHECK POWER SUPPLY** at the motor and make sure it agrees with the motor rating. Do not operate the winch until proper power is supplied to the motor.
- 1.4.9 **TEST CONNECTIONS** by operating the winch. The rotation of the drum must agree with the labels on the control device, and the motor must stop when the control is released.

CONTACT THE FACTORY OR A QUALIFIED PROFESSIONAL FOR HELP.

1.5 Installing the Wire Rope

Important!

- Use wire rope and other rigging equipment rated for the size of the largest load you will be moving.
- Do not drag the wire rope through dirt or debris that could cause damage, or poor operation.
- Always wear protective clothing when handling wire rope.

⚠WARNING

Install the wire rope securely to the winch drum. A poorly secured wire rope could come loose from its anchor and allow the load to escape.

Do not use 3/16 inch or smaller wire rope on standard drums. To do so could cause damage to the wire rope and allow the load to escape.

Install the wire rope so it is wound correctly as shown on the winch and brake will not work properly, and could allow the load to escape, see Figure 4.

Figure 4 – Installing the Wire Rope

install the wire rope so it is underwound on the drum as shown

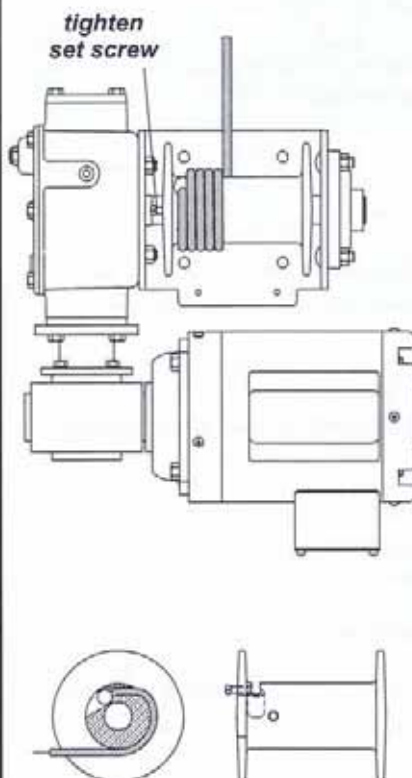

*typical installation shown
left lay – underwound*

Wire rope assemblies with anchor fittings can be purchased from Thern, Inc.

- 1.5.1 PURCHASE THE PROPER WIRE ROPE for your application. Keep the following in mind when selecting a wire rope. Contact a reputable wire rope supplier for help.
 - a. BREAKING STRENGTH of new wire rope should be at least 3 times greater than the largest load placed on the winch. If loads are lifted or pulled on an incline, the breaking strength must be at least 5 times greater than the largest load. These are minimum values and will vary with the type of load and how you are moving it.
 - b. WIRE ROPE LAY must agree with the winding direction of the drum to help insure proper winding.
 - c. WE RECOMMEND 7x19 galvanized aircraft cable for diameters up to 5/16 inch. Do not use 3/16 inch or smaller wire rope on standard drums.
- 1.5.2 ANCHOR THE WIRE ROPE to the drum using either the set screw or quick disconnect anchor.
 - a. SET SCREW ANCHOR. See Figure 4.
 - PASS THE WIRE ROPE under the drum from the front and position it in the slot in the drum. Make sure at least 1/2 inch of wire rope extends past the set screw, and the end of the wire rope does not protrude out where it will interfere with wire rope winding onto the drum.
 - TIGHTEN THE SET SCREW to hold the wire rope in place. Hold the wire rope down while tightening so the wire rope does not push up out of the slot.
 - b. QUICK DISCONNECT ANCHOR. See Figure 4.
 - PASS THE WIRE ROPE under the drum from the front and position the anchor fitting in the groove in the drum.
 - PULL THE WIRE ROPE to firmly lodge the anchor fitting in place.
- 1.5.3 WIND FOUR FULL WRAPS of wire rope onto the drum by operating the winch while holding the wire rope taut. **These wraps serve as anchor wraps and must remain on the drum at all times.** See Figure 4.

CONTACT A REPUTABLE WIRE ROPE SUPPLIER FOR HELP.

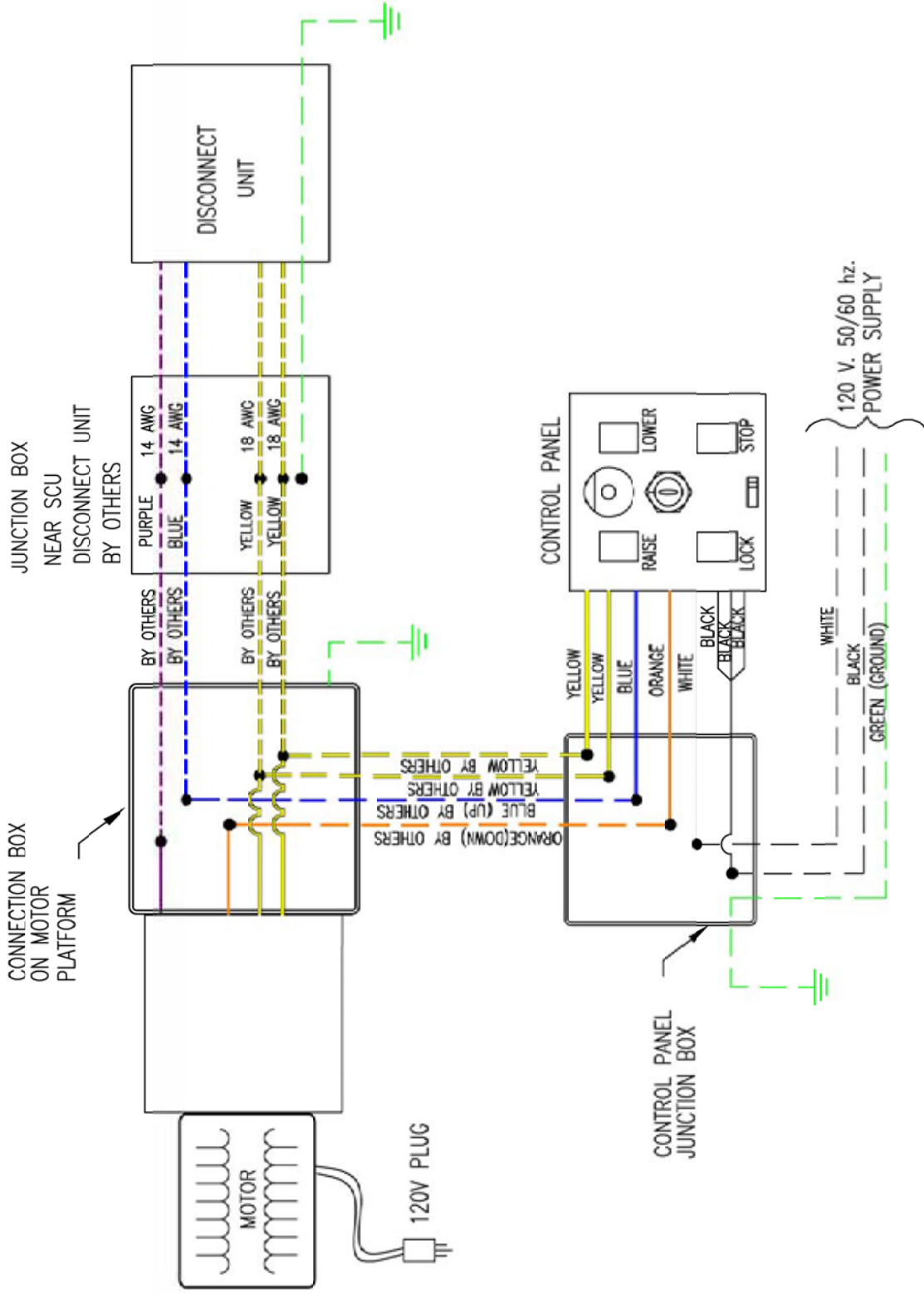

Figure 1.3.1 Wiring Diagram

1.6 Cable Clamp Assembly

WARNING

To prevent serious personal injury, the cable clamp must be properly assembled and the cable must be properly routed through the clamp as specified within. No attempt at lifting any load should be made until all specification conditions are met. Use only the cable provided by Lighting & Lowering Systems with this clamp.

1.6.1 Fixing Cable in the Clamp

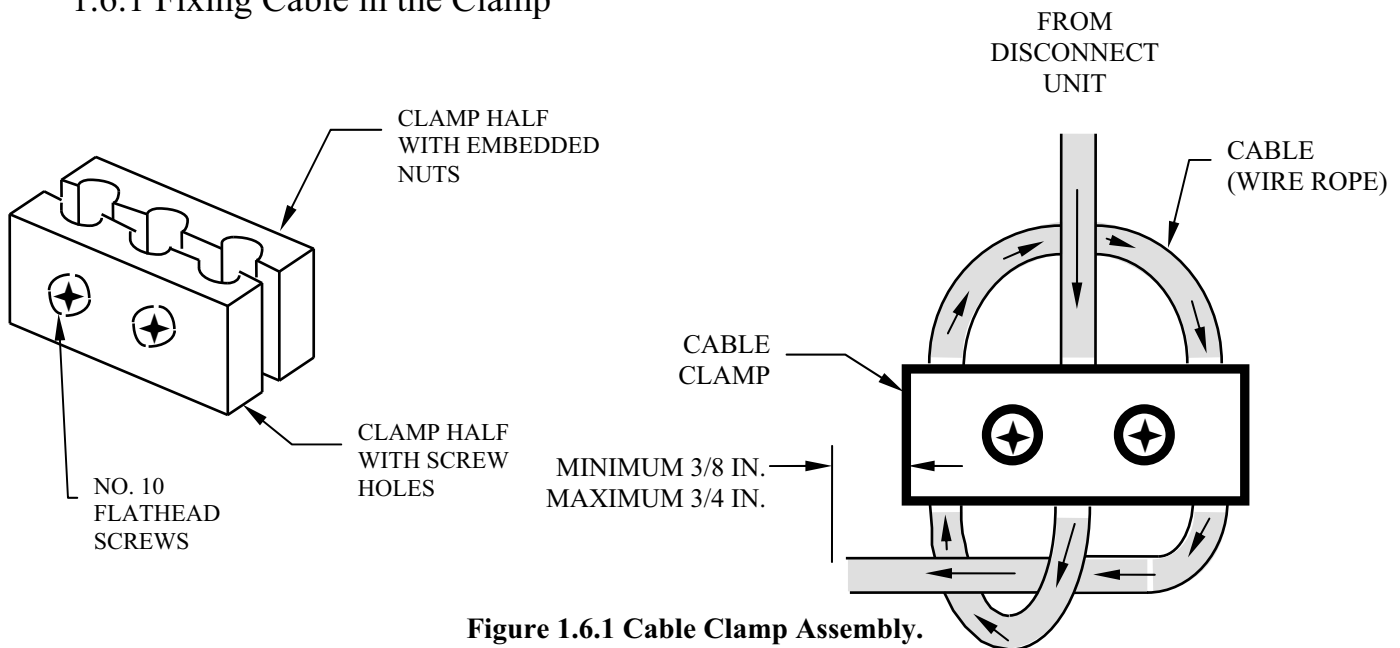

Figure 1.6.1 Cable Clamp Assembly.

To facilitate ease of feeding the wire through the cable clamp, trim leading end of cable square making sure there are no protruding strands of wire. **Do Not Use Lubricant Of Any Kind On The Portion Of Cable that Is To Be Within The Cable Clamp.**

1. Loosen screws of clamp to separate the clamp halves enough to fit the cable through the notches but do not remove the screws completely.
2. Feed cable end coming from the bottom of the disconnect unit into the center notches of the cable clamp. Pull approximately 5 inches of cable through the clamp.
3. Insert the end of the cable through one of the side notches. Cable should move easily through the notches of the clamp. If the cable is too loose and moves out of the notches, tighten the screws slightly until the cable stays within the notches. Do not pull cable tight.
4. Pass the end of the cable across to the other side notch and through the clamp.
5. End of cable must be fed through loop formed by cable coming from center notch and first side notch so that when cable is pulled tight the loop closes on the end portion of the cable.

6. After the system is installed, lower the unit to the floor level. There should be only 6 turns of rope on the drum. **Cut off all access cable.**
7. Carefully pull the cable loops tight by back pulling on the cable portion coming from the disconnect unit. Be sure cable remains within the notches of the clamp. With all loops small as possible, tighten no. 10 screws in an alternating pattern until tight. End of cable should extend approximately 3/8 to 3/4 inch past edge of cable clamp. **Trim cable end as required.**
8. Check cable clamp, cable, and screws for tightness every time cable clamp is lowered when the system is operated.

1.7 Canopy Installation (optional)

WARNING Electrical power to the contact unit must be off until all installation or servicing to the contact unit or light is completed.

	CAN-12-65	CAN-8-65
DEFINITION	Spring loaded Canopy used with SCU-2X Contact Unit	Spring loaded Canopy used with SCU-2A-MS Contact Unit
DIMENSION	10 1/4" Diameter 2 1/4" Depth	8" Diameter 2 1/4" Depth
MATERIAL	Brass	Brass
FINISH	Polished Bright Brass	Polished Bright Brass
SPRINGS	Two Springs at 180° extend when unit is unlocked, and compresses to ceiling when locked.	Two Springs at 180° extend when unit is unlocked, and compresses to ceiling when locked.
CEILING	Opening should be from 8" to 8 1/2" Diameter hole.	Opening should be 6" Diameter hole.

Table 1.7.1 Canopy Installation. (Refer to Figure 1.7.1 for other details)

1.7.1 Installing CAN-8-65

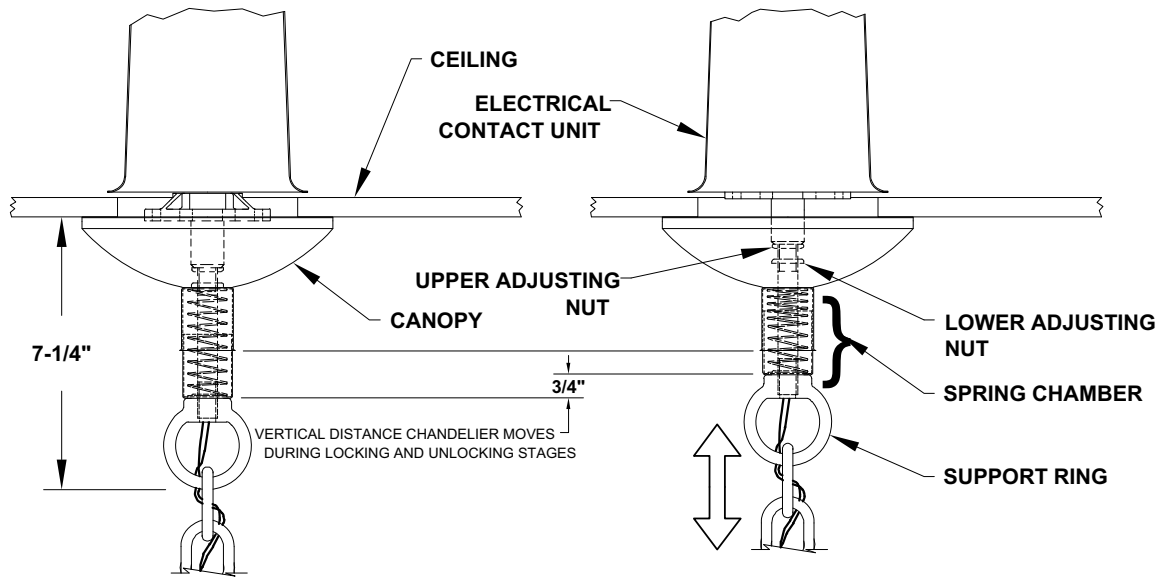

Figure 1.7.1 Canopy Installation CAN-8-65.

During the lowering or raising of the fixture, when the electrical contacts engage within the ceiling mounted locking device, there is approximately $\frac{3}{4}$ " travel up and down to set the locking mechanism. The height compensating canopy will adjust to this condition to assure that the canopy will remain against the ceiling surface.

CANOPY: One piece 8" diameter and $2\frac{1}{4}$ " deep heavy gauge spinning with standard polished brass finish.

SPRING CHAMBER: Telescoping cups with bright brass finish enclose a $\frac{3}{8}$ " pipe stem that connects the electrical contact unit with the chandelier support ring. A large diameter compression spring within the chamber provides a constant and even pressure to keep the canopy against ceiling.

SUPPORTING RING: A heavy duty solid brass ring is threaded onto the end of the $\frac{3}{8}$ " stem and secured with a lock nut. Electrical wires are fed through a center hole in the ring. At least 3 chains or connecting links are required to attach to the fixture.

1.7.2 Installing CAN-12-65

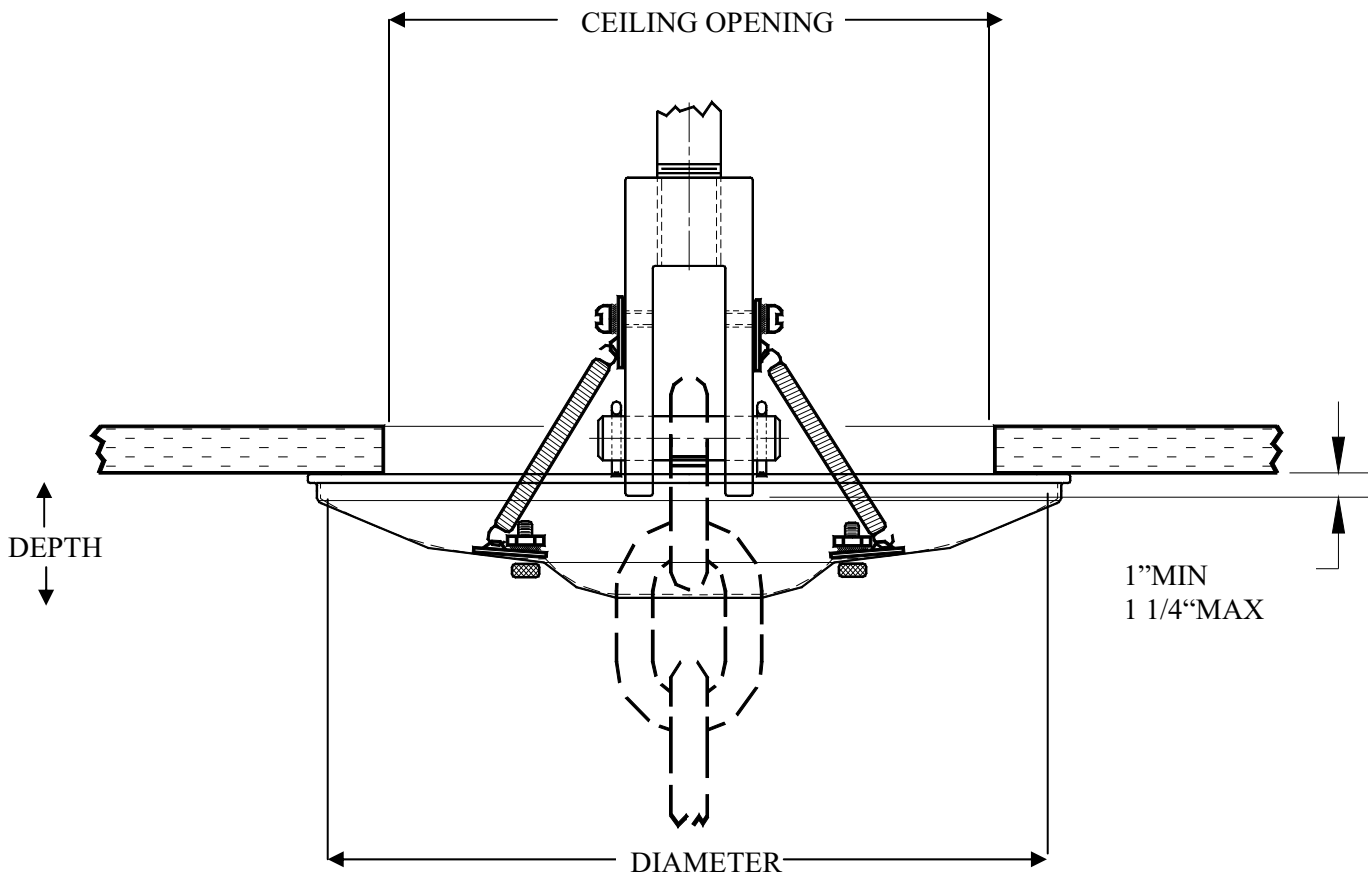

Figure 1.7.2 Canopy Installation CAN-12-65.

Refer to the installation instructions for suspension contact units prior to installing this height compensating spring loaded decorative canopy. For mounting the SCU-2X units, shackle modification section should also be studied.

- After contact suspension unit has been installed and electrical wiring is in place, the canopy and light fixture/chandelier is ready to install. The fixture requires at least 4 chain or connecting links to attach to the fixture.

NOTE: The canopy may be removed from the shackle at any time.

- With the bottom portion of the ceiling, use the 8-32 X 3/8 in. screws and lock washers to secure four spring mounting bases to shackle hanger.

(NOTE: Chain links shown in Figure 1.7.1 are optional depending upon application and requirements.)

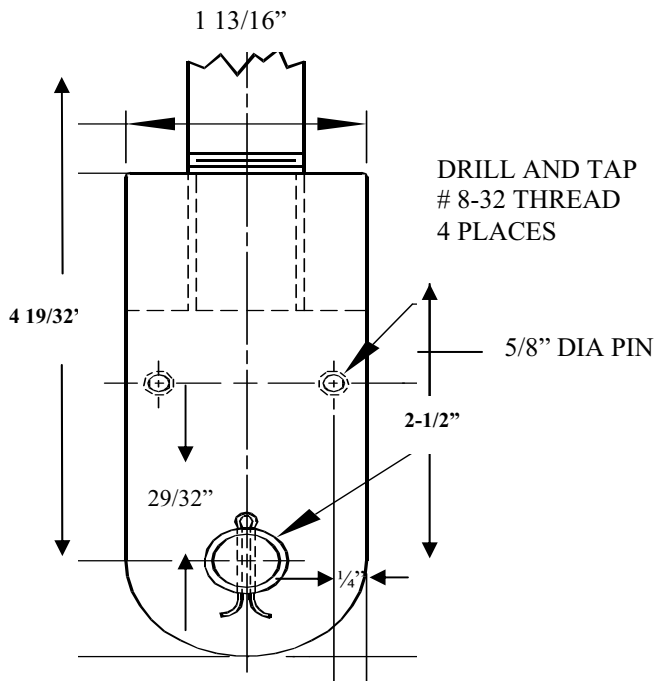

Figure 1.7.3 Shackle Modification (only for SCU-2X units).

- Remove cotter pin from one end of the shackle pin and slide pin out of holes.
- Insert end of the fixture support chain through the center hole in the canopy and up into the shackle fork.
- Reinsert shackle pin and through end link of chain. Reinsert cotter pin and bend back legs of cotter pin.
- Attach springs to spring mounting bases in canopy and at shackle.
- Make fixture electrical wire connections as required.

Canopy and shackle come ready to install from factory with all parts if ordered with suspension contact units.

Chapter

2

Testing

NOTE TO THE OPERATOR

During the testing of the system at the manufacturing facility, a short lowering distance was programmed into the control panel. That distance must be changed the first time the system and control panel are operated. Before the system was shipped from the factory, the control panel was operated so that the system remains in unlocked position having the tension on the cable. This is so as to prevent unnecessary uncoiling of the control cable. When the control panel is turned on for the first time, initially there will be momentary red lights in addition to a short beep. Then no indicator lights should be illuminated. In any other case, refer to the “Alternate conditions” section at the end.

2.1 Programming the Lowering Distance for the first time

WARNING

Electronic control is designed to operate on 105-135 volts AC 50/60 Hz. Failure to operate the control at the specified voltage may result in control failure and/or electronic component failure.

Control must be installed in electrical connection box before turning on electrical power to the control.

The Control Panel must be installed in a location with visibility to the fixture being raised and lowered.

IMPORTANT

The motorized winch system, MLS-XXX-TH8 is designed to protect the system against overload. When an overload occurs during the engagement of the upper and lower assemblies of the SCU unit, the current sensor relay will open the circuit, the motor will stop, the control panel beeper will sound and red light of the “LOCK” switch will blink.

Press the “LOCK” switch of the control panel. It will lower the test weight or the light fixture about an inch and **the lowering cable will be under tension.**

Press the “AUTO-LOWER” switch to lower the fixture more. (The system will raise about an inch and then start lowering.)

Check the SCU mounting installation and try it again. Make it sure that upper assembly of the SCU unit is mounted on a rigid platform and it is leveled. (Please see figure M-4).

The recommended way to check the engagement of the lower and the upper assemblies of the SCU unit

- Press and hold the “RAISE” switch of the control panel to raise the trial weight or the chandelier to the top **but release the “RAISE” switch before the SCU unit assemblies engage** (When they are 6 to 12 inches apart). By pressing and releasing the “RAISE” switch in short increments raise the weight to reach to the very top position in the disconnect unit. When it gets to that point, the beeper will sound and red light of the “LOCK” will blink on and off.
- Press “LOCK” switch. The system will lower into the lock position. **At this stage there will be slack on the lowering cable**

*** Do not disconnect the current sensor.**

*** Do not change the setting of the current sensor.**

*** Do not change the wiring of the system.**

Programming Instructions

IMPORTANT

The system must be installed, raised and locked. The control panel must be installed in an approved electrical connection box. A minimum 20 lbs weight must be present at the mounting adapter of the movable lower portion of the disconnect unit during any operation.

1. **Add a weight** to the mounting adapter of the movable lower portion of the disconnect unit. The weight should be **minimum 20 lbs and maximum according to the system**. This weight is temporary and will serve to aid dislodging of the lower portion of the electrical disconnect unit from the upper fixed portion until the light fixture is permanently mounted.
2. **Unscrew the cover plate of the control unit.**
3. **Make sure that the key lock power “ON/OFF” switch is set to OFF. Turn the electric power supply on. Turn the key lower power switch ON.** Initially the lights will be on momentarily, along with a short beep. The “LOCK” switch red light will remain lit.
4. **Slide the “TEACH-RUN” switch to “TEACH” mode.** The red lights on the “STOP” switch will start blinking. Should the red lights of the “LOCK” switch be illuminated, in addition to this blinking, follow the instructions given in the “Alternate Conditions” section at the end.
5. Now you are ready to program the lowering distance into the control panel. The distance is expressed as time units. It is necessary to accumulate time required for the system to reach the desired lowering distance in the following manner.

Press “AUTO-LOWER” switch and hold. The fixture will rise for approx. 4 seconds and then it will start lowering. The light on the “RAISE” switch will go on for a few seconds. Then the light of the “LOCK” switch will blink along with intermittent beeps. Release the “AUTO-LOWER” switch and press the “LOCK” switch. The light of the “AUTO-LOWER” switch will be on momentarily. After that, the red light of the “LOCK” switch will be continuously illuminated and the light of the “STOP” switch will blink. Press the “AUTO-LOWER” switch again. The light of the “RAISE” switch will be momentarily on. Continue to press the switch. After that short period of time, the control panel will lower the weight and the light of the “AUTO-LOWER” switch turn on to signify the active process. If after approximately 10 seconds of pressing the “AUTO-LOWER” switch, there is no noticeable lowering movement of the weight, release the switch. This will stop the system. Go to the “Alternate Conditions” section at the end and follow instructions concerning this situation.

Continue to press this switch and release it when the desired lowering distance for the fixture is achieved. The time required to lower the weight or fixture to the desired lowering distance will be added to the programming. If it is not possible to continuously press the “AUTO-LOWER” switch, for the entire duration, intermittent releases of the switch will not affect the

total accumulation of time as long as no other function switch on the control panel is pressed during the TEACH process.

6. **Slide the “TEACH-RUN” switch to “RUN” mode.** (It is very important that the power to the control and programming of the lowering distance is not interrupted during the TEACH mode. An interruption would erase the memory of the time required for lowering the system and the process will have to be started again.) The time, and thus the distance (during steps 4 to 6) are permanently stored in the system. That stored time will be repeated every time the “AUTO-LOWER” switch is activated. ON/OFF of the control panel and power interruptions will not affect the stored time. Reprogramming the lowering distance will change this time.
7. **Assemble the cover.**
8. **Raise and lock the system.** Please follow the operating instructions to raise and lock the fixture.

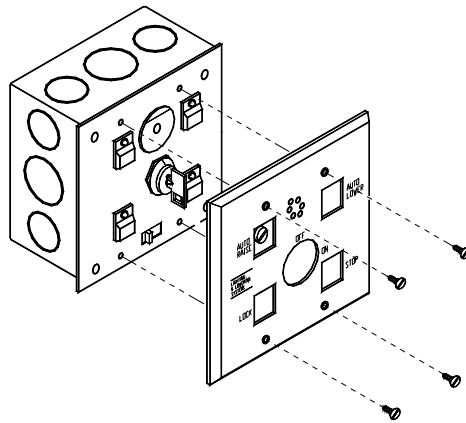

Figure 2.1.1 Disassembling and assembling the control panel cover.

Chapter

3

Programming

NOTE TO THE OPERATOR

During testing of the system, a lowering distance may have been programmed into the control panel. That distance must be changed the first time the system and control panel are operated after installing the light fixture.

3.1 Programming or Reprogramming the Lowering Distance

Refer to figure 2.1.1 for this section.

WARNING

Electronic control is designed to operate on 105-135 volts AC 50/60 Hz. Failure to operate the control at the specified voltage may result in control failure and/or electronic component failure.

Control must be installed in electrical connection box before turning on electrical power to the control.

IMPORTANT

- **Only the lowering distance, (the distance that the light fixture will travel from the top to the location selected by the user for servicing), is programmed by the user.**
- **All other times required for the precise operation of the system are pre-programmed into the control panel at the factory and are not changeable by the operator.**

Programming Instructions

IMPORTANT

The system must be installed, raised and locked. The control panel must be installed in an approved electrical connection box.

- 1. Unscrew the cover plate.**
- 2. Turn the power on.** Initially the lights will be on momentarily, along with a short beep. The “LOCK” switch red light will remain lit.
- 3. Slide the “TEACH-RUN” switch to “TEACH” mode.** The red lights on the “STOP” switch will start blinking
- 4. Press “AUTO-LOWER” switch and hold.** The fixture will rise for approx. 4 seconds and then it will start lowering. Continue to press this switch and release it when the desired lowering distance for the fixture is achieved.
- 4. Slide the “TEACH-RUN” switch to “RUN” mode.**
- 5. Assemble the cover.**
- 6. Raise and lock the system.** Please follow the operating instructions to raise and lock the fixture.

Chapter

4

Operation

This control panel uses advanced micro-electric components to provide the semi-automatic operation of the motorized raising and lowering system. Understanding the features and how they work will aid the operator of the system program and operate the control panel.

IMPORTANT

- **Special computer logic is included, that prevents the wrong function to occur should the operator accidentally press the wrong function.**
- **Never operate the control without being installed in an approved electrical connection box.**

In case of an electrical power outage

An electrical power outage has no effect on the control panel's memory. In addition, should power be turned off at the ON/OFF switch or electrical power be interrupted during a function in progress, the control panel will remember where it was at the time of the power outage and continue with that function at exactly the same place it left off the next time the power is restored to the control panel.

4.1 Operating Instructions for the System and Control Panel

TO LOWER THE FIXTURE

- 1. Turn the power on.** Initially the lights will be on momentarily, along with a short beep. The "LOCK" switch red light will remain lit.
- 2. Press and release the "AUTO-LOWER" switch.** Initially, the system will rise for approx. 4 seconds and green light of the "RAISE" switch will be on. Then the system will start lowering and green light of the "AUTO-LOWER" switch will be on. The fixture will be lowered to the previously programmed position and then stop automatically. (For programming it, please turn over.)

TO RAISE AND LOCK THE FIXTURE

- 1. Press and hold the “RAISE” switch.** Green Light of the “RAISE” switch will be lit.
- 2. Release the “RAISE” switch before the assembly engages** (when the fixture is about 2’ away from top). By pressing and releasing the “RAISE” switch **in short increments** (waiting for the fixture to stop rotating) raise the fixture to reach to the very top position in the disconnect unit. This is done so that the fixture gets enough time to settle down because it will rotate in this process. When it reaches that point, red light of the “LOCK” switch will blink along with periodic beeping.
- 3. Press the “LOCK” switch.** System will lower into the locked position. The beeping will stop and red light of the “LOCK” switch will remain lit as long as the system stays locked.
- 4. Turn the power off.**

To stop the system, press the “STOP” button. Always follow “STOP” function by “RAISE” irrespective of the fixture position. Do not press “STOP” when fixture is less than 2’ away from the top.

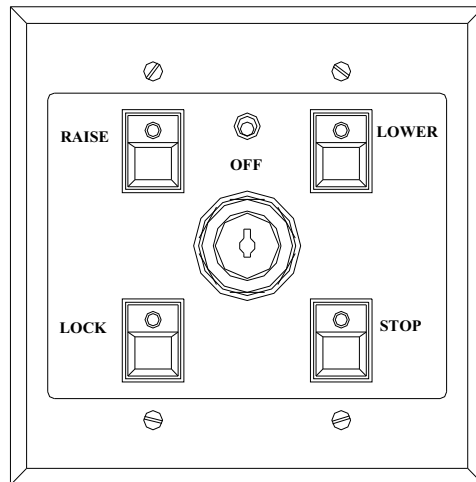

Figure 4.1.1 Control Panel.

4.2 Features of the electronic control panel

- **A power on/off switch that is key-locked** so that the system cannot be operated by anyone other than the designated user.
- **Green light on “AUTO-LOWER” switch** shows that the system is operating to lower fixture.
- **Green light on “RAISE” switch** shows that the system is operating to raise fixture.
- **Blinking red light on “STOP” switch** indicates that the user is programming the lowering distance and that the “TEACH/RUN” switch is in the “TEACH” mode.
- **Blinking red light on “LOCK” switch** indicates that the light fixture is all the way at the top and required pressing of the “LOCK” switch to lock the fixture in place. This will always occur in conjunction with sounding of a beeper. All other functions of the control panel are inoperable except the key lock switch.
- **Red light on “LOCK” switch**, when continuously illuminated, indicates that the light fixture and the system are in the locked position. The “RAISE” function will not work when in this mode.
- **Momentary red lights on the “STOP” and “LOCK” switches** indicates that the power to the control panel has just been turned on using the key lock switch. This will occur in conjunction with a short beep and will stop after control panel has reached full power.
- **An electronic beeper** alerts the operator that the fixture has reached the very top of its cycle and requires that the “LOCK” switch be pressed to lock the fixture in place.
- **A special “TEACH/RUN” switch** in the panel of the control permits the programming of the lowering distance when set in the “TEACH” position. Full operational capabilities of the control panel are enabled when the switch is in the “RUN” position. The switch is **not accessible when the wall plate for the control panel is in place**.
- **An emergency “STOP” switch** turns any of the functions OFF except the blinking light of the “LOCK” switch. **ALL ENABLED FUNCTIONS OF THE CONTROL WILL START AT THE BEGINNING OF THEIR SEQUENCE REGARDLESS OF WHERE THEY WERE AT THE TIME WHEN THE “STOP” SWITCH WAS PRESSED. THE “STOP” FUNCTION MUST ALWAYS BE FOLLOWED BY THE “RAISE” FUNCTION ONLY.**
- **Continuous memory** permits the control to remember exactly the lowering distance that was programmed into it. This is permanently stored until another distance, based on time units, is programmed into the control using the “TEACH” function.

4.3 Alternate Conditions

4.3.1 Alternate conditions when programming the system for the first time

When the key lock power “ON/OFF” switch is turned on for the first time, if the red light of the “LOCK” switch is on continuously while beginning the “TEACH” mode, press the “RAISE” switch. The system will rise until it reaches the very top (should be just a very short distance at this point). The red light of the “LOCK” switch will blink along with a beep. Continue following the programming instructions now.

If, after operating the control panel in the lowering direction during the “TEACH” mode for approximately 10 seconds, there is no noticeable lowering of the weight or light fixture, the

system is in locked position. To correct this situation, press the “RAISE” switch. The system will rise until it gets to the very top. The red light of the “LOCK” switch will blink along with a beep. Continue following the programming instructions now.

4.3.2 Programming for lowering distance in excess of 25 ft.

1. Determine the lowering distance of the light fixture. Find out ½ of this distance.
2. From the locked position of the disconnect unit, with the red light of the “LOCK” switch continuously on, follow the operating instructions for lowering the light fixture. Lower it the ½ of the lowering distance determined in step 1.
3. Follow steps 4 to 6 of the programming instructions.
4. When operating the system, perform the step 2 twice.

IMPORTANT

- **The control panel should be left in the RUN mode except when programming the lowering distance.**
- **When in the TEACH mode, only the first press of the “AUTO-LOWER” switch will raise the system to unlock the disconnect unit. Any subsequent pressing of that switch, will add time in the lowering direction with the light of the “AUTO-LOWER” switch on. An interruption in power to the control panel or pressing another function switch will start the process over again.**
- **When in the RUN mode, every time the “AUTO-LOWER” switch is pressed, the control panel will activate the system to raise first and then lower to the programmed height above the floor. Should the lowering process be stopped part way through its stored program and the “AUTO-LOWER” switch be pressed again to continue the lowering, it may be necessary to press the “STOP” switch to prevent the weight or light fixture from touching the floor. During the “AUTO-LOWER” function, if the “STOP” switch is pressed, the system will be OUT OF SEQUENCE. The “STOP” function must always be followed by the “RAISE” function.**
- **Never press “STOP” switch when the fixture is less than 2’ away from the very top. Always follow the “STOP” function with the “RAISE” function irrespective of the fixture position.**
- **The raise time (and thus the distance) cannot be programmed. When the “RAISE” switch is pressed, the system will operate in the raise direction until it reaches the very top of its cycle.**

4.4 FAQ:

Frequently asked questions which an operator may come across working with the system are as follows. The questions are represented in terms of problems and the corresponding reasons and/or solutions are provided. For other questions, and technical assistance, call 708-681-4330.

<u>Problem:</u>	<u>Reasons and/or solutions:</u>
1) The system will not turn on	a) Input power may not be on. b) Wire connections may be improper.
2) The disconnect unit will not unlock	a) Fixture may not be heavy enough. (The fixture should be heavier than 50 lbs) b) Micro-switch may be out of adjustment. c) Follow the procedure for locking the system again and then try to unlock. "LOWER" then "STOP" when the "LOWER" switch light is on. Repeat till unlocks. d) Disconnect unit may not be level or moving. e) If the "STOP" light is flashing at this time, the system needs to be locked again. Programming may also be needed.
3) Fixture goes in wrong directions	a) The connection of blue and orange wires may be wrong. b) The cable on the winch-drum may be on backwards.
4) Fixture stops and the "LOCK" switch light flashes with beeping.	a) Current sensor may be set wrong. In this case call factory.
5) The motor starts to smoke and/or leak oil (this is applicable to 10 min duty motor only)	a) The motor may be running for longer than 10 minutes at a time. Do not run a motor for more than this time.
6) Lowering cable does not use all of the winch drum	a) Fleet angle to the first pulley may be wrong. It is important to know that the disconnect unit itself has a pulley and if no other pulleys are employed, the disconnect unit must be installed minimum 12 to maximum 30 feet from the drum.
7) The system will not lock	a) The disconnect unit may not be level. b) The fixture and therefore the disconnect unit does not have enough space to move when locking.