

Exposed Cable System with Portable Lowering Tool •
Manual System suitable for Indoor and Outdoor Use

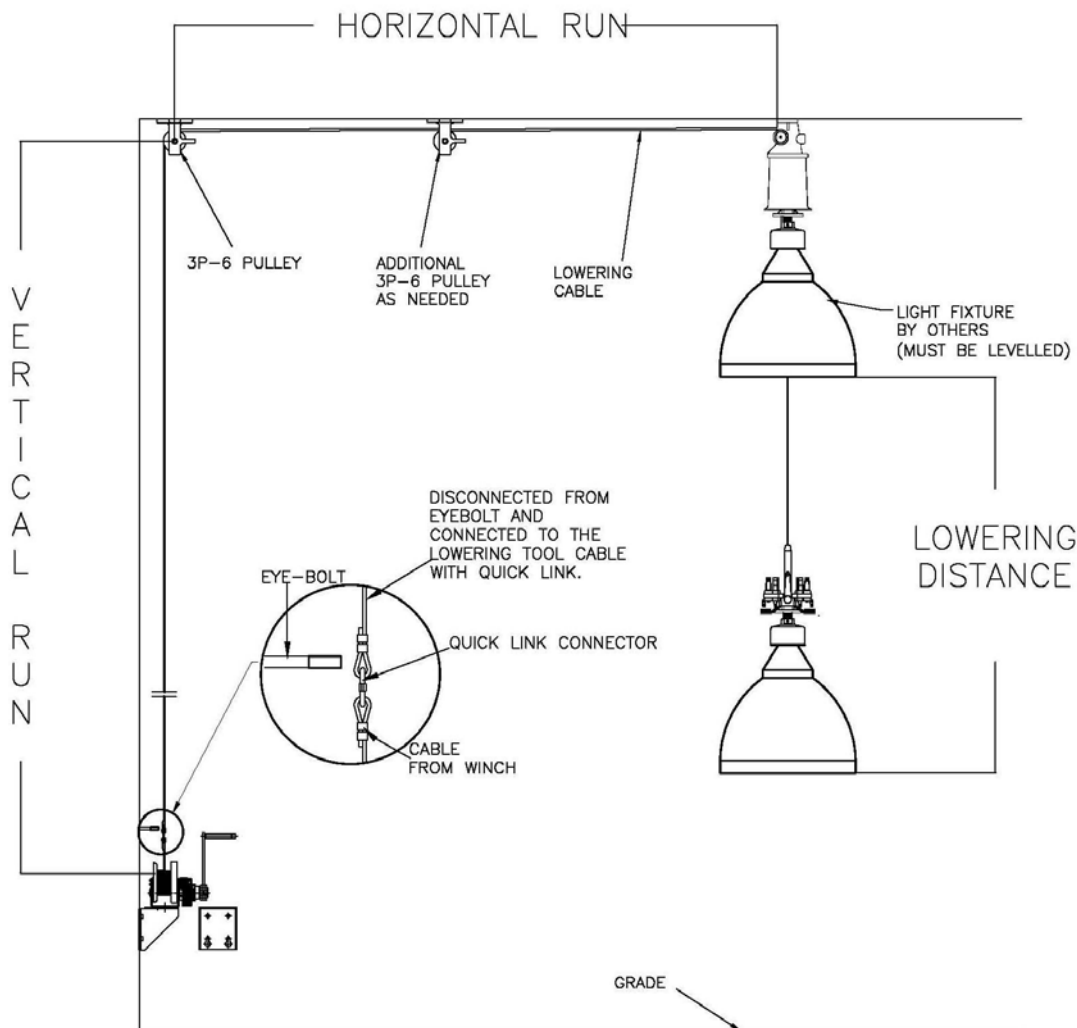

Details shown are intended as an application example only. Actual installation details may vary. Contact manufacturer's representative or factory for specific details about special installation application or other information. Lifting capacity is 400 lbs and must not be exceeded.

Disconnect unit support must be horizontal. Disconnect unit and pulley mounting structure must be strong enough to support 5 X load of the fixture in all directions.

This system can be used with inclined ceilings provided the horizontal support for disconnect unit fulfilling all the requirements as discussed is provided by others.

* Tool Sold Separately.

** Specifications subject to change without notice.



PWE-400-100-4C

FOR FIXTURES WEIGHTING FROM 20 TO 400 LBS.

Principal Components of this system:

1. **Electrical Disconnect Unit Assembly:**

It comes with four electrical contacts plus one ground as standard. (Additional contacts are available) and includes fittings for surface mounting to a horizontal structure and flange/stem adapter for mounting the fixture to the disconnect unit. This system can be used with inclined ceilings provided the horizontal support for disconnect unit fulfilling all the above mentioned requirements is provided by others.

2. **LB-1 Locking Eyebolt**

3. GA4407-XX 5/32" Galvanized Steel Aircraft Cable Assembly: Total cable length required is calculated as: Lowering Distance + 5 ft + Horizontal Run + Vertical Run (Optional Stainless Steel Cable).

4. **One 3P-6 Pulley (Optional PB-1 Pulley Box):** (See details under mounting accessories).

Pulley box can be used for appearance benefits. However, the pulley box guides the cable only at a 90 degree angle. A 3P-6 pulley can guide the cable at a desired angle. Optional extra 3P-6 pulleys are available and must be used at every 6-30' of horizontal straight cable run and for every change in direction of the cable to a different plane. Optional 3P-3 pulleys are available to guide cable path away from obstructions. (See details under mounting accessories).

Portable Lowering Tool:

When the system is in the locked stage, there is no tension on the cable because of the lock that holds the fixture in place and it is not hanging on the cable. The eyebolt provides a secondary safety feature for this system. Only one portable lowering tool is required for a project. This saves cost. Quick connector provides easy connection of the cable from the lowering tool to the cable from the system. Details of the Portable Lowering Tool are available under Lowering and Mounting Components.

Specifications Guide

❖ The EDU shall have a 3-way tracking guide and support. It shall be constructed of precision cast high strength aluminum alloy 356-T6. A permanently fixed position piece incorporating a special tracking guide system permits the moveable portion of the *Disconnect Unit* to align in the same position every time the system is operated, thereby eliminating the need to re-orientate the fixture. The Electrical Disconnect Unit shall have twin high strength stainless steel locking cams securing the load of the *Lower Contact Assembly* and fixture. All tension on the cable is relieved when the fixture is in the raised position.

❖ The MULTI-CONTACT Connector assembly shall be modular for easy installation and retrofit requirements. All **pin and socket contacts** shall be insertable and removable. The connector shall also have 4 size 12 contacts. Material of contacts shall be copper with nickel plating, and with gold plating over nickel per MIL-G-45204. Electrical contacts shall have a rating of 20 year mean time between failures. All hardware shall be corrosion resistant stainless steel. It shall have a self-aligning and self-adjusting mechanical system comprised of two principal assemblies:

The UPPER CONTACT HALF shall house the socket contacts. It shall incorporate spring assisted polymer contact body with precision-machined stainless steel guideposts. The socket contact body shall have integral guideposts for precise contact alignment.

The LOWER CONTACT HALF shall house the pin contacts comprised of spring assisted polymer contact body with precision-machined stainless steel guidepost receivers. The pin contact body aligns with guideposts of integral socket body guideposts.

❖ The wire leads are potted in Superflex® Black RTV Silicone, an industrial grade sealant for bonding and sealing.

❖ The unit shall have a guidepost constructed of precision cast high strength stainless steel. It shall utilize a cast-in-place guide bar for precise alignment of *Lower Contact Assembly* with the fixed portion of the *EDU*.

❖ The **EDU shall have** twin (2) tracking support arms made of precision cast high strength stainless steel. When locked in the *3-Way Tracking Guide and Support* notches, the *Twin Tracking/Support Arms* shall hold the weight of the fixture and components and it shall remove all tension from the *Control Cable or Lowering Cable*.

❖ The lower contact assembly shall be constructed of precision cast high strength aluminum alloy. It shall feature a cast-in-place guide that mate with the fixed portion of the *Disconnect Unit* to aid in tracking and stability. All hardware used on the *Lower Contact Assembly* as well as the entire *Disconnect Unit* shall be made of corrosion resistant stainless steel.

❖ The disconnect unit shall have a **HOUSING SEAL** made up of a spun aluminum closure ring with a sealing gasket constructed of extra flexible polymer providing a weather-tight seal between *Lower Contact Assembly* and *Disconnect Unit Cover*. This provides a flexible environmental seal. Seal swipes and conforms to interior of cylinder housing during all operating stages of the disconnect unit.

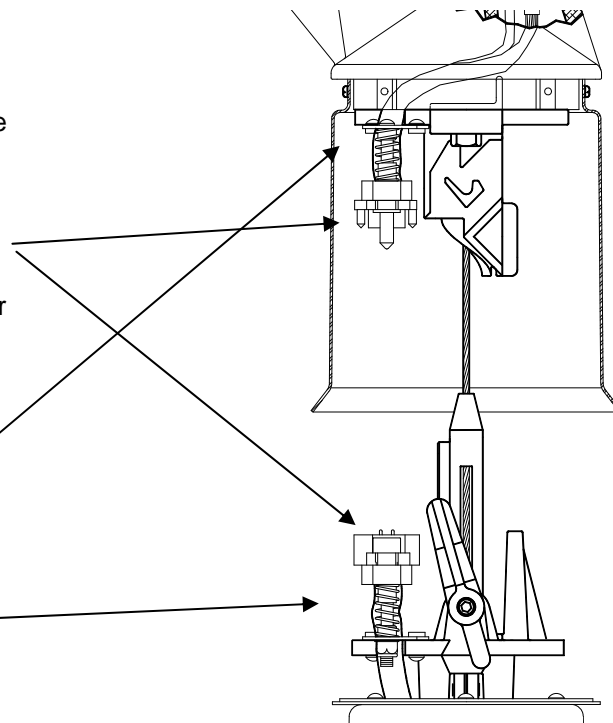

Electrical Contact Rating: 600 volt, 20A maximum input.
(2 circuit standard, optional up to 4 circuits)
Mechanical Rating: 400 lbs with 6:1 safety factor
Weight: 8.5 LBS

SYSTEM DESIGNED SPECIFICALLY FOR USE WITH LIGHT FIXTURES, CAMERAS, AND RELATED EQUIPMENT ONLY.
NOT FOR LIFTING PEOPLE OR THINGS OVER PEOPLE.
SPECIFICATIONS SUBJECT TO CHANGE WITHOUT NOTICE.

Specifications Guide

Frontal View

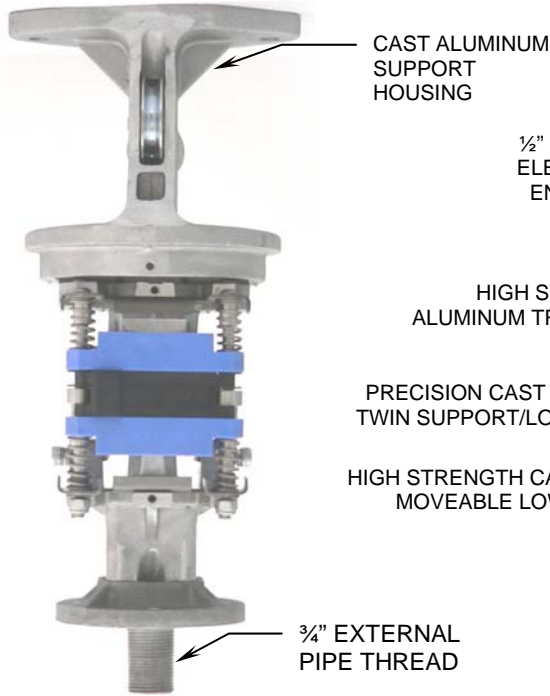

Side View

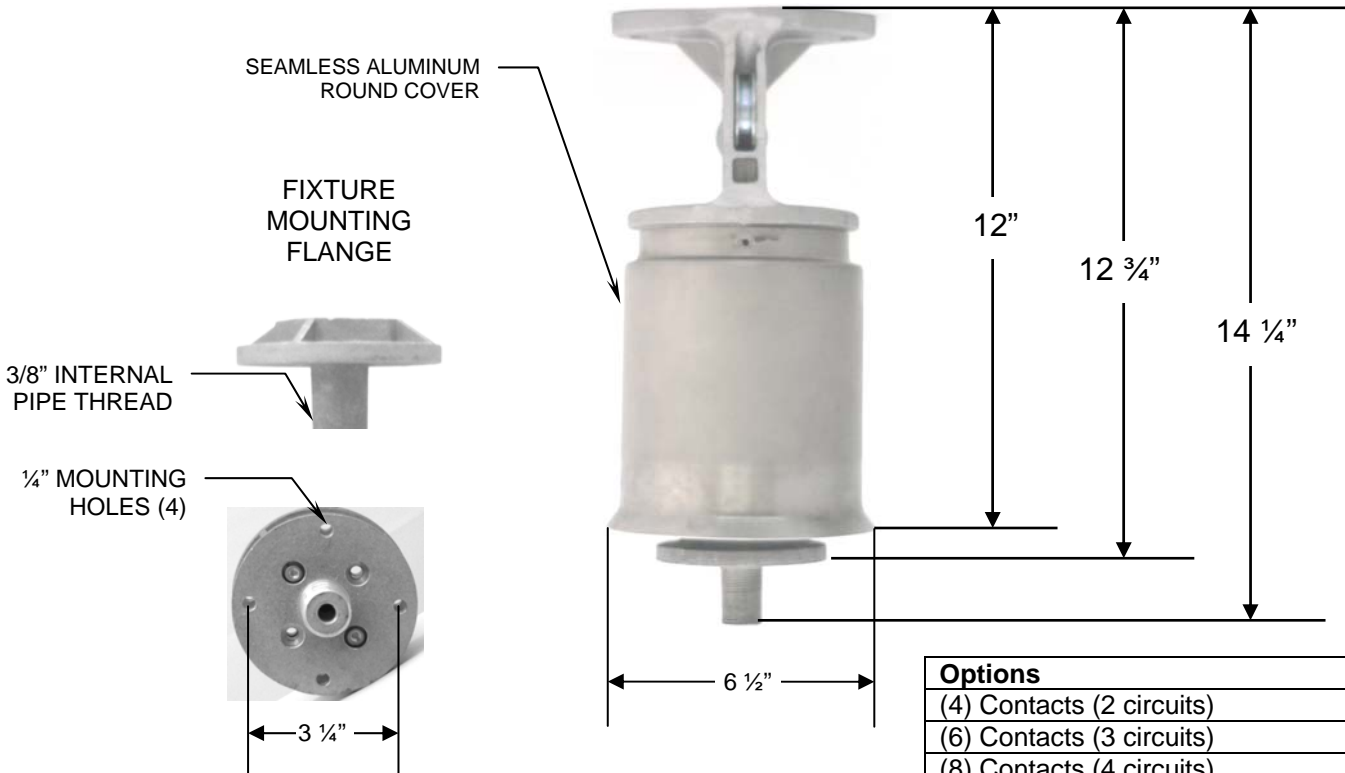
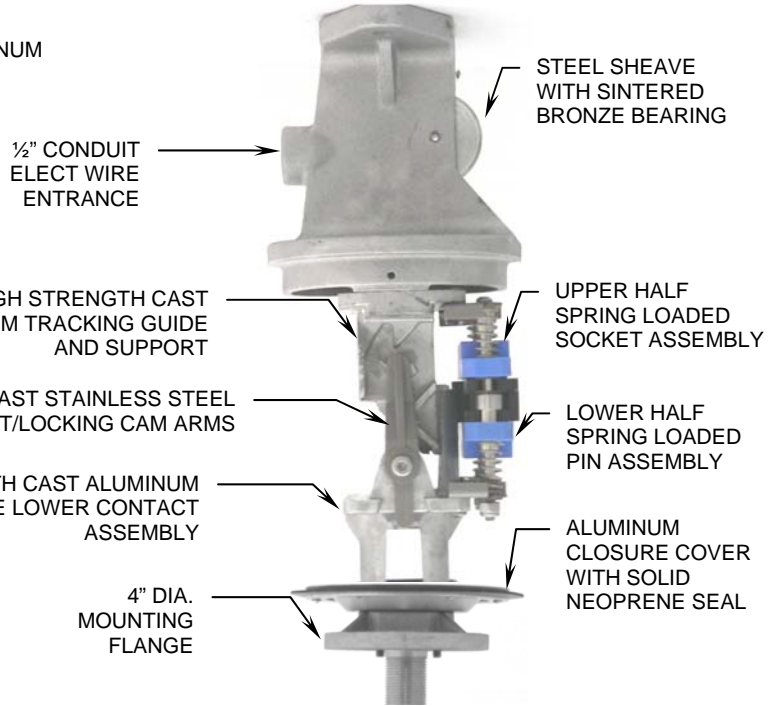

Options	Suffix
(4) Contacts (2 circuits)	-4C
(6) Contacts (3 circuits)	-6C
(8) Contacts (4 circuits)	-8C
3/8" Internal Pipe Thread Mounting	-38
Other mounting-consult factory	

Cable Orientation Options:

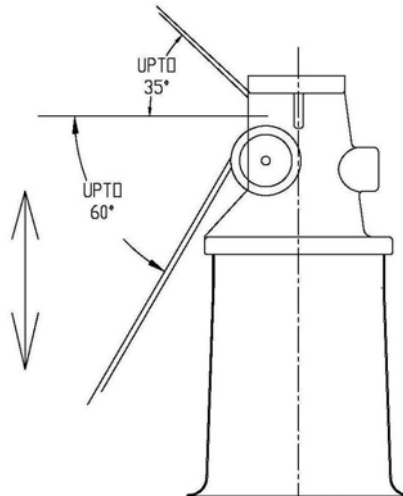

The disconnect unit allows the cable path orientation at an angle. The pulley installed in the upper casting attached to the disconnect unit guides the cable in the required orientation.

Mounting Details:

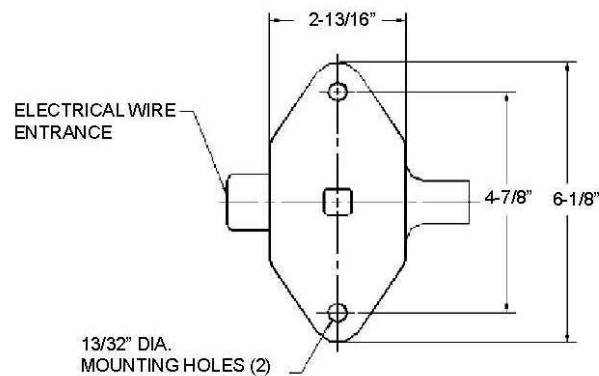

The disconnect unit must be mounted on rigid horizontal support. This support must be approved by others to be able to withstand static and dynamic loading of at least 5 X the weight of the fixture in all directions. Square center hole is optional. Please specify if required at the time of ordering.



PWE-400-100-4C

FOR FIXTURES WEIGHTING FROM 20 TO 400 LBS.

Specification Guide for Other Components:

- ❖ The system shall utilize a CONTROL CABLE (mechanical raising and lowering cable) made of galvanized steel 5/32 inch diameter 7 x 19 construction cable. One end of the cable shall have a heavy-duty stainless steel connector link (Optional Stainless Steel cable for very corrosive environments). A GB-2P LOWERING TOOL (only 1 needed per order) shall be supplied with each order. It is a lowering tool consisting of the gearbox, disc brake, frame and lowering cable. The gear box shall be of heavy duty design to provide reliability, long life, and ease of operation. It incorporates solid steel heat treated gears for maximum durability and strength. It is equipped with a special automatically actuated disc brake for load holding ability and the prevention of the load free wheeling. It shall have a corrosive resistant finish. The raising and lowering (control) cable shall be made of galvanized/stainless steel 5/32-inch diameter 7 x 19 construction. Minimum breaking strength shall be 2400lbs.
- ❖ Various types of pulleys are available and should be designed for the exact load and gearbox. All pulleys shall have oilite bronze bearings for maintenance free life. This also insures their use for dirty atmosphere applications. Painted pulleys are available for highly corrosive areas. Pulleys are required when vertical or horizontal changes in direction occur. Five types are available for various mounting and load requirements. It is important that pulleys are properly aligned when installing and always take pulley friction into consideration if loads are near the limits.
- ❖ PB-1 pulley box (optional) for use instead of a 3P-6 pulley assembly. The PB-1 allows conduit to be connected to the pulley box. It shall be mounted for cable turns of 90 degrees when it becomes necessary for the lowering cable to always run inside a conduit (dirty atmospheric conditions, exposure to extreme conditions).

Other system is also available for fixture weighing above 400 lbs. Contact factory for details.

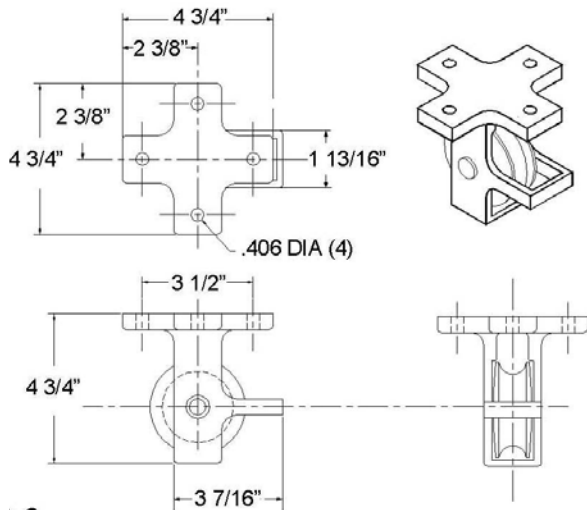

3P-6

Various types of pulleys are available and should be designed for exact load and gear box. All pulleys have oilite bronze bearings for maintenance free life. This also insures their use for dirty atmosphere applications. Painted pulleys are available for highly corrosive areas. Pulleys can be spaced 6-30' apart on horizontal runs. A pulley must be used at every 30' of horizontal straight runs. Pulleys are required when vertical or horizontal changes in direction occur. It is important that pulleys are properly aligned. The centerline of the pulley-sheave groove must coincide with the centerline of the cable path when installing. Always take pulley friction into consideration if loads are near limits of the gear box. Pulleys must be installed on rigid surfaces which are able to withstand at least 5 X load of the fixture in all directions. The installation must be approved by others.

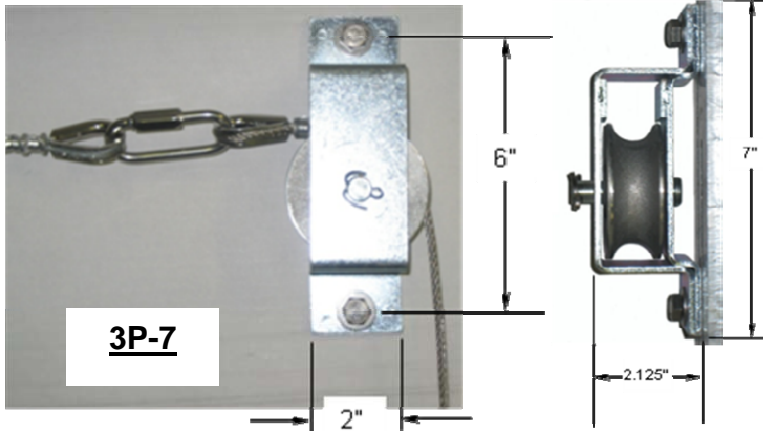

3P-7

3P-6

Load capacity for a 3P-6 pulley is 20-400 lbs. A 3P-6 pulley can facilitate a change in direction of the cable from wall to ceiling i.e. from vertical to horizontal. 3P-6 pulleys should be spaced 6-30' apart on horizontal runs. Change in direction of cable to angles other than 90 degrees is possible. See page p3 for details. This pulley allows the twisted quick-link to pass through.

3P-7

A 3P-7 pulley can facilitate a change in direction of the cable on the same plane i.e. on the ceiling or on the wall. The pulley allows the cable connecting link to pass through.

Load capacity: Up to 400 lb. fixtures.

Frame Material: Frame material of zinc plated 7ggs. Steel.

Frame Material Option: Stainless steel frame. Contact factory.

Sheave Material: Sheave of cast aluminum with oilite bronze bearing.

Mounting: Two mounting holes for 3/8" bolts. Hardware by others. Type of hardware depends on the type of structure that the pulley is mounted to. Structure must not move while the system is in operation.

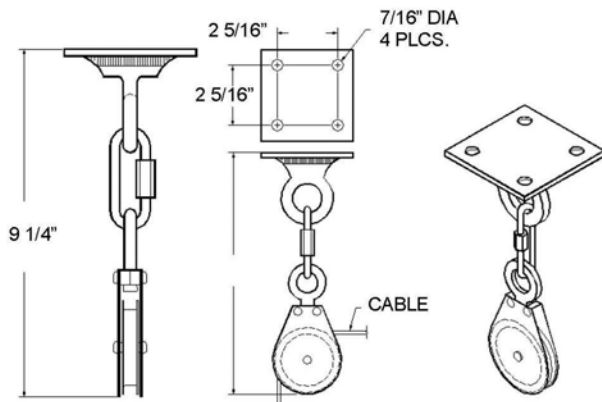

3P-5

3P-5

Load capacity for a 3P-5 pulley is 20-400 lbs. A 3P-5 pulley can facilitate a change in direction of the cable in different planes due to the swivel nature.

* Specifications subject to change without notice.

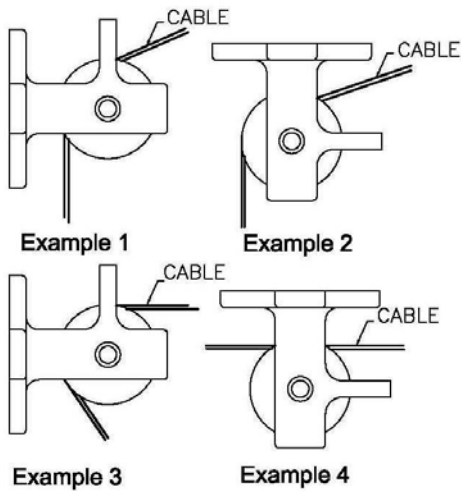

3P-6 and 4P-4 Uses

3P-6 and 4P-4 pulleys (depending upon load) can facilitate a change in direction of the cable from wall to ceiling i.e. from vertical to horizontal. These pulleys should be spaced 6-30' apart on horizontal runs. The above examples show that change in direction of cable to angles other than 90 degrees is possible. These pulleys can be placed horizontally (examples 2 and 4), vertically (examples 1 and 3) and on inclined surfaces for maximum versatility as long as the cable path is aligned to the pulley sheave groove and as long as the cable path is not interfered by any obstacles.

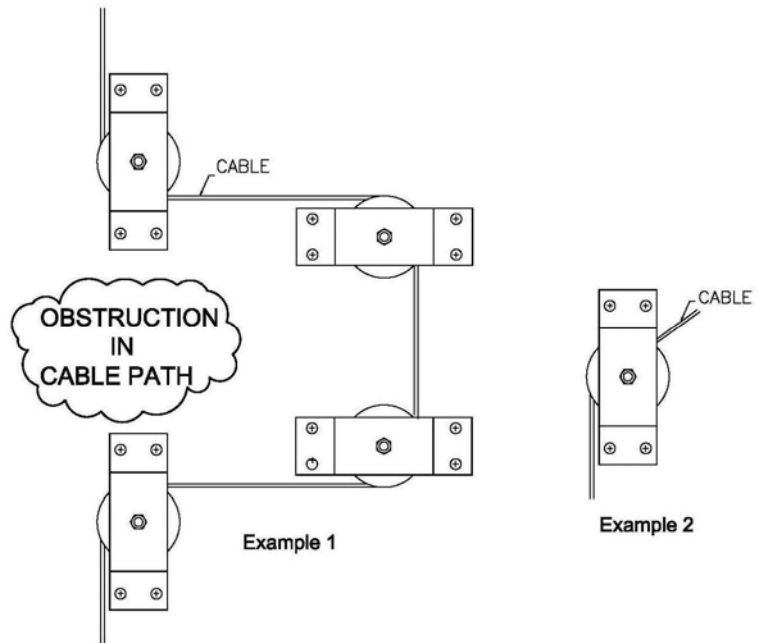

3P-3 and 3P-7 Uses

3P-3 and 3P-7 pulleys (depending upon load) can facilitate a change in direction of the cable on the same plane. Example 1 is a simple way using 4 pulleys to go around an obstruction in the cable path.

* Specifications subject to change without notice. Details shown are intended as an application example only. Actual installation details may vary. Contact manufacturer's representative or factory for specific details about special installation application or other information. Lifting capacity is 400 lbs and must not be exceeded.

SLB-1

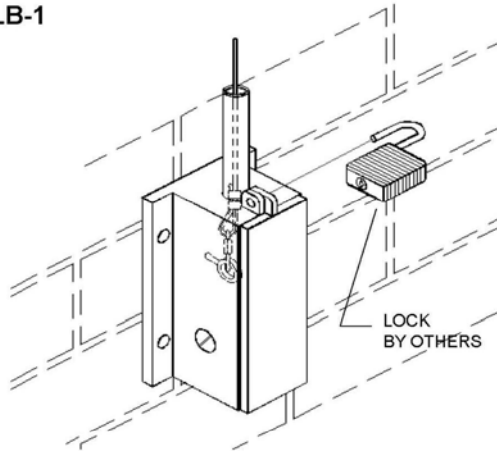

- Security Locking Box Design SLB-1

- Pulley Box PB-1

- Locking Bolt LB-1

- Wall Conduit Mounting Bracket CBC-169

Each lowering cable must be terminated in a locking system. Two types are available to prevent unauthorized personnel from lowering the fixtures. If the lowering cable is mounted indoors and a security locking box is not required the locking bolt **LB-1** design can be considered. When conduit entry is required and maximum protection and corrosion conditions exist, the use of **SLB-1** security locking box is recommended. The box is cast aluminum. For highly corrosive areas, an optional painted unit is available. Vandal proof construction uses no screws, nuts or bolts to enter unit. The lowering tool to service this box is the **LT-4**. For locations where concealed boxes are required, consult factory for decorative designs. Each security locking box uses a **CCS-1** conduit cable shuttle to connect to the lowering cable to pass through the conduit.

PB-1

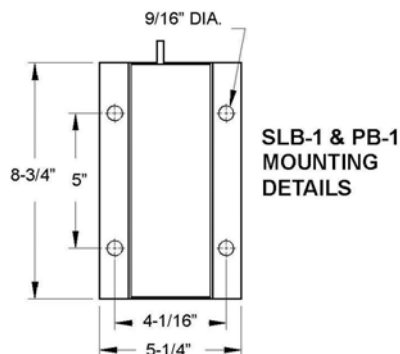
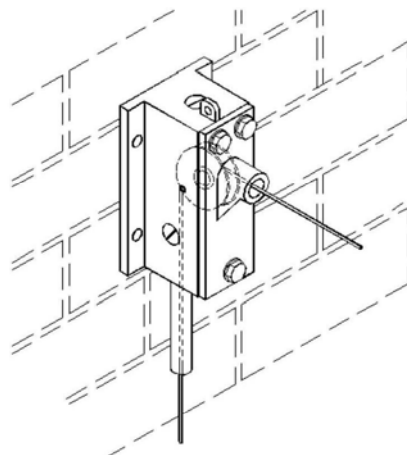

LB-1

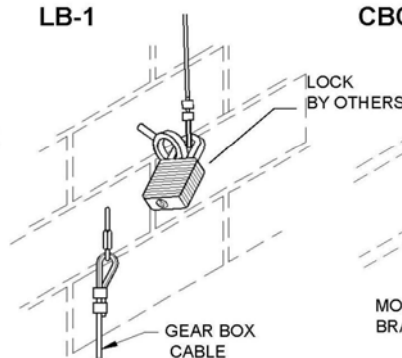

CBC-169

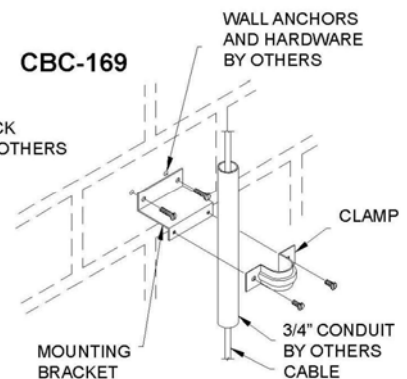

All gear boxes and lowering tools are of heavy duty design to provide reliability, long life, and ease of operation. They incorporate heat treated gears for maximum durability and strength. All are equipped with a special automatically actuated disc brake for better load holding ability and the prevention of the load free wheeling. They are available for permanent installation or portable use indoors or outdoors for wall mounting or pole mounting. Each system is custom tailored to work with required load and operation for the raising/lowering specifications. "L" shaped mounting bracket is made of heavy duty steel with a primed coated finish.



GB-2P's grouped together to save space.

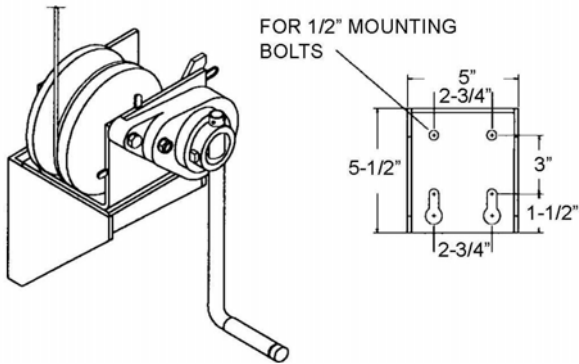
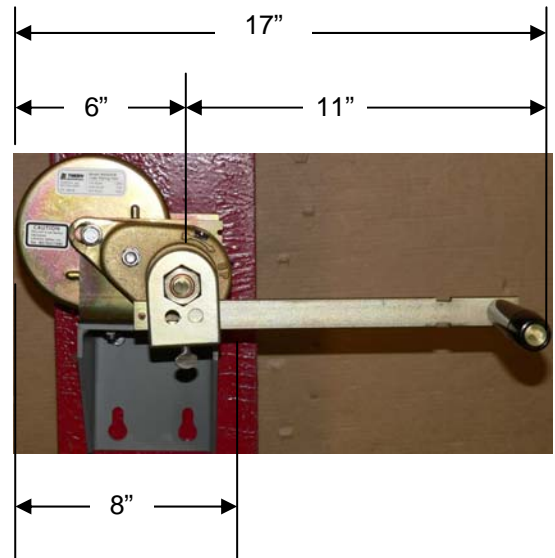

CATALOG # GB-2P
PERMANENT OR PORTABLE
WALL MOUNTED GEAR BOX FOR
FIXTURES UP TO 400 LBS.

CAT. #	MIN. LOAD LBS	DRUM CAPACITY	WEIGHT LBS.
GB-2P	16	90 FT.	20
GB-2PA	16	180 FT.	22

- ◆ All Lighting & Lowering Systems gear boxes and lowering tools are designed for material handling usage only.
- ◆ Not for lifting people or things over people.
- ◆ Specifications subject to change without notice.

