

Arm and Disconnect Unit for Pole Mounting Multi-Function Surveillance Cameras

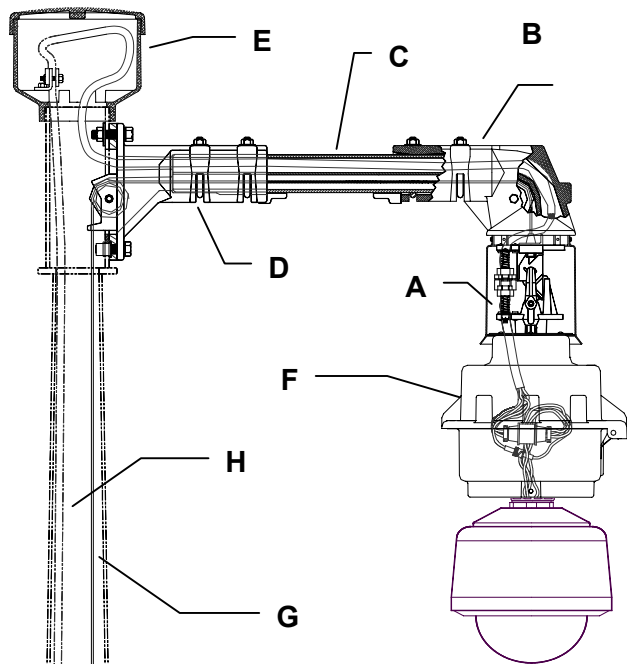

- A. ELECTRICAL AND SIGNAL DISCONNECT UNIT WITH MULTI-CONTACT CONNECTOR.
- B. DISCONNECT UNIT FITTER WITH PULLEY AND U-BOLT MOUNTING FOR INTERLOCKING NON-ROTATING ARM.
- C. DIVIDED PIPE ARM: 2-3/8 IN. O.D. SEPARATES CONTROL CABLE AND ELECTRICAL AND SIGNAL WIRES. POSITION ALIGNED NON-ROTATING.
- D. POLE MOUNTED FITTER WITH PULLEY AND U-BOLT MOUNTING. MOUNTS DIRECTLY TO 4 INCH O.D. TENON ON POLE TOP.
- E. POLE TOP CONNECTION BOX WITH COVER HOUSES SIGNAL & POWER CABLE STRAIN RELIEF.
- F. CAMERA CONNECTION BOX PROVIDED WITH STABILIZING WEIGHTS. EASY OPEN SWING DOWN DESIGN PERMITS QUICK ACCESS TO ELECTRICAL/SIGNAL WIRES FROM CAMERA ASSEMBLY.
- G. CONTROL CABLE CONSTRUCTED OF 1/8 INCH DIA. STAINLESS STEEL 7 X 19 CONSTRUCTION CABLE. THE CONTROL CABLE IS THE ONLY C

MOVE WHEN THE CAMERA IS BEING RAISED AND LOWERED.

- H. ONE PIECE SIGNAL CORD WITH COAX AND POWER FROM DISCONNECT UNIT TO POLE BASE OR TO CABINET WITHOUT THE NEED OF EXTRA CONNECTORS.

J. POLE.

K. CABINET (BY OTHERS)

TOTAL EPA (inc. arm assy. & camera): 2.50
TOTAL WEIGHT: 95 LBS.

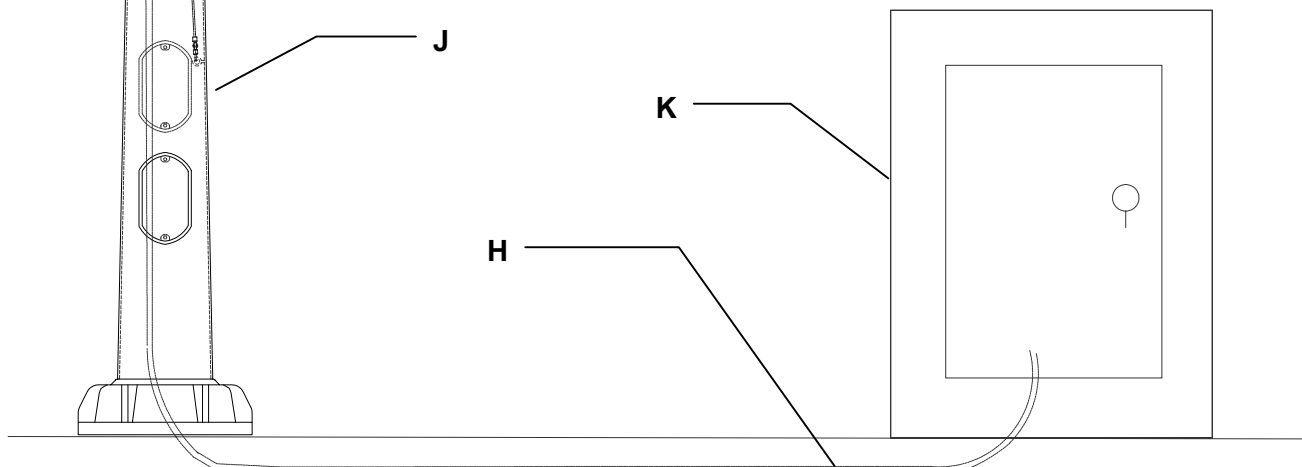

EDU-16HD ELECTRICAL DISCONNECT UNIT

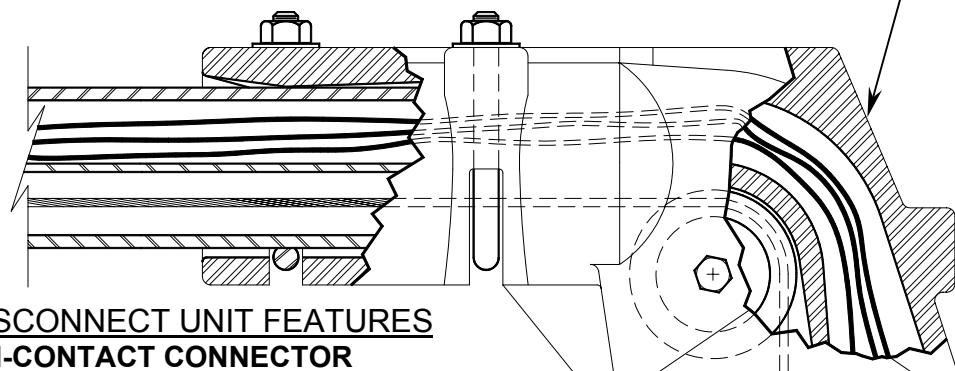

MOUNTING FITTERS
Cast aluminum alloy. Completely isolates the moving control cable from the signal cable. Molybdenum filled nylon pulley has sintered bronze permanently lubricated bearing for maintenance free life. This insures their use for dirty atmosphere and corrosive environments.

Outdoor Model: (Shown)
For 2-3/8" O.D. Galv. pipe. Tower, pole, & wall mtg.
Indoor Model: Has upper flange for surface mtg.

DISCONNECT UNIT FEATURES

***MULTI-CONTACT CONNECTOR**
Precision mating upper (socket half of connector) and lower (pin half of connector) portions aided with stainless steel spring assisted guides. Connector provides 16 electrical and signal contacts to handle the wide variety of cameras and components in today's marketplace. Both halves of connector spring assisted to minimize environmental vibrations and provide continuous resistant forces to maintain connector closure and help in ejecting of connector halves during the unlocking sequence of the disconnect unit. Connector halves designed as separate modules for easier removal and replacement should changes be needed for camera and component equipment upgrades. Connector is self-aligning and self-adjusting and is environmentally sealed. All contacts are copper with MIL SPEC **gold plating**. Socket contacts have beryllium copper springs that assure constant contact with pins.

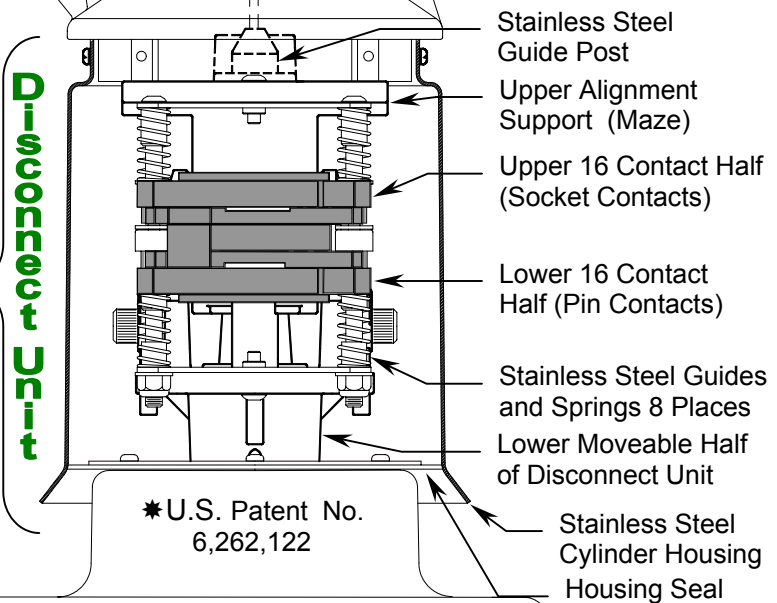

DISCONNECT UNIT

Stainless Steel Guide Post
Upper Alignment Support (Maze)
Upper 16 Contact Half (Socket Contacts)
Lower 16 Contact Half (Pin Contacts)
Stainless Steel Guides and Springs 8 Places
Lower Moveable Half of Disconnect Unit
Stainless Steel Cylinder Housing
Housing Seal

*U.S. Patent No. 6,262,122

STRUCTURAL COMPONENTS

Upper alignment support and lower moveable half of disconnect unit are high strength cast aluminum alloy 356-T6. Main guide post and structural support arms are precision cast stainless steel.

CYLINDER HOUSING

Standard housing is hydrospun heavy gauge stainless steel. Painted finish to match surrounding system and camera is optional.

HOUSING SEAL

Flexible environmental seal at lower housing opening is standard neoprene. Seal swipes and conforms to interior of cylinder housing during all operating stages of the disconnect unit.

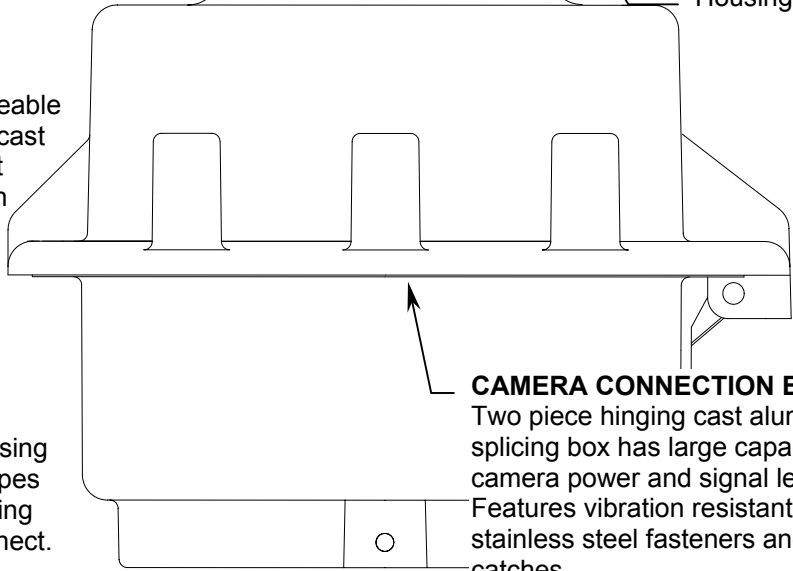

CAMERA CONNECTION BOX
Two piece hinging cast aluminum splicing box has large capacity for camera power and signal leads. Features vibration resistant 1/4 turn stainless steel fasteners and safety catches.

16HD-HEAVY DUTY ELECTRICAL DISCONNECT UNIT FOR MULTI-FUNCTION CAMERAS

OPERATION OF THE MULTI-CONTACT CONNECTOR

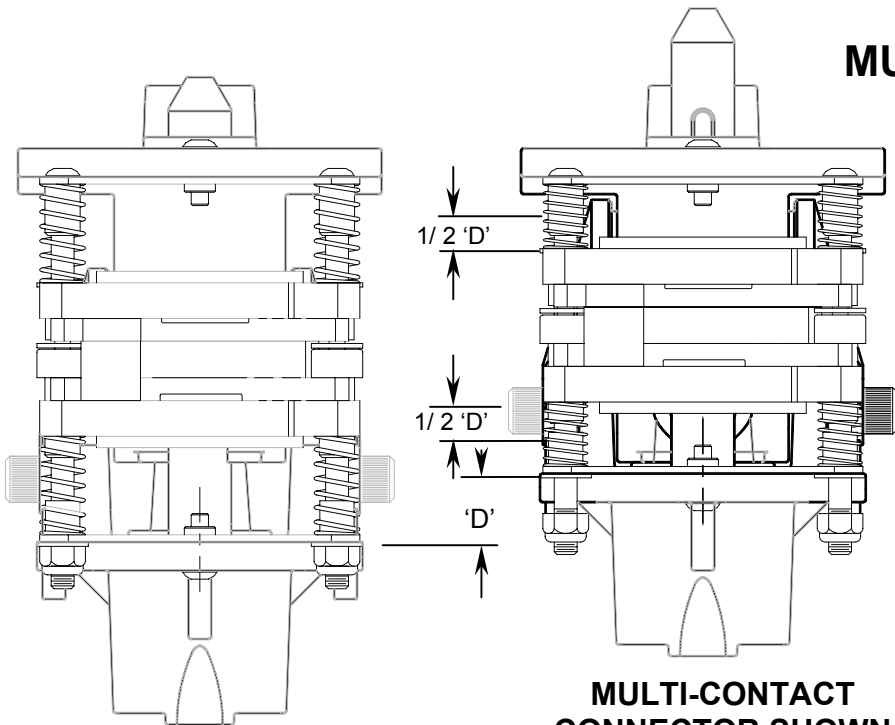

**MULTI-CONTACT
CONNECTOR SHOWN
IN LOCKED POSITION**

**MULTI-CONTACT
CONNECTOR SHOWN
IN LOCKING OR
UNLOCKING POSITION**

Distance 'D' is the total distance that the disconnect unit must travel to lock and unlock. This unique design (patented) by Camera Lowering Systems provides spring-assisted upper and lower portions of the connector that splits the total travel distance in half, thereby equalizing the retaining forces required to assure a uniform seal. Because the upper half (the socket contacts) and the lower half (the pin contacts) float within the disconnect unit, the connector is isolated from vibrations that would affect signal discontinuity.

LOCKED POSITION

When the disconnect unit is in the locked position, the multi-contact connector has all contacts engaged. Springs are slightly compressed to provide equal and constant pressure against the two halves to maintain an environmental seal.

LOCKING POSITION & UNLOCKING POSITION

During the operation to lock or unlock the disconnect unit, the springs of both halves of the connector compress in equal proportions and stainless steel

CONTACTS AND WIRES

- Twin connectors provide 16 Heavy Duty 12gge gold plated over copper electrical contacts.
- Contacts are securely contained within a polymer body.
- Upper and lower groups of wires and contacts are sealed from the external environment using glandular seals around the wires and a soft gasket at the line of separation.
- Wires are 16 conductor composite heavy gauge electrical and signal wires with high quality RG59 coax. (See cable specs). A one-piece composite cable from disconnect unit to the cabinet is standard.
- Optional wires: Sixteen 14gge wires with flexible hypalon jacket. The upper portion wires run from socket half of disconnect unit to Pole Top Junction Box. Bottom half runs from pin connector to Camera Junction Box.

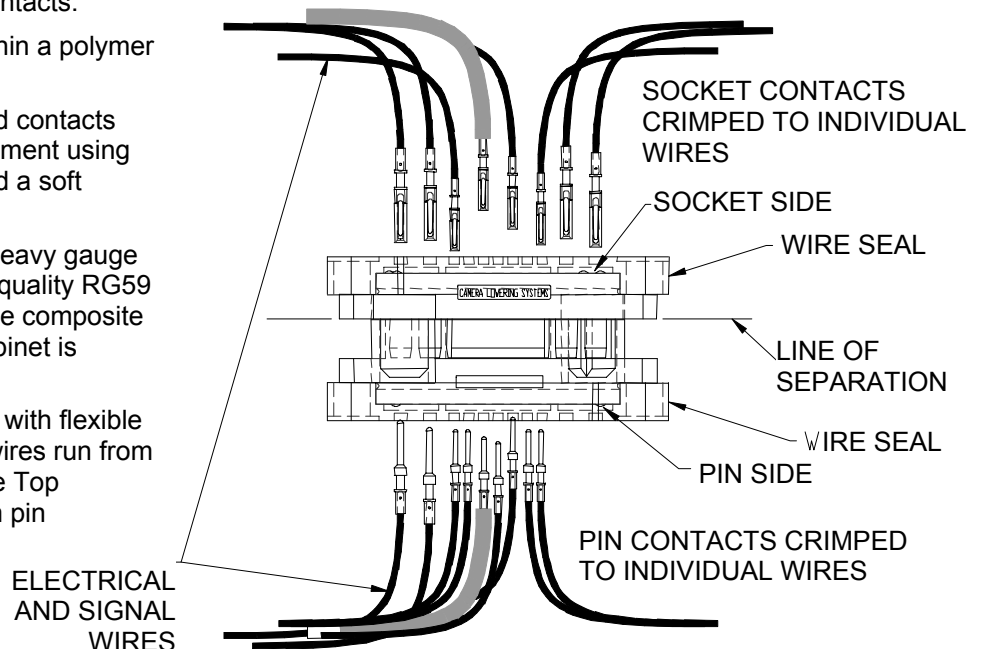

16HD DISCONNECT UNIT FOR MULTI-FUNCTION CAMERAS

OPERATION OF THE MULTI-CONTACT CONNECTOR

guide posts move through linear bearings as the support arms of the disconnect unit move into the proper position within the tracking guide. Electrical and signal contacts remain fully engaged and the camera is still operational.

RAISING POSITION

The connector assembly utilizes precision machined stainless steel guides to align the two halves of the connector. These are used in addition to the 3-way guides of the disconnect unit. A set of alignment posts built into the connector halves serve as the final guides to assure that all pin and socket contacts are perfectly lined up before engagement.

LOWERING POSITION

As the disconnect unit begins to unlock, the springs expand and the guide posts begin to separate. The last parts of the connector to disengage are the electrical and signal contacts. Any ground wires or shielding use a longer pin contact to assure that they are the very last to disengage before the camera is lowered for servicing.

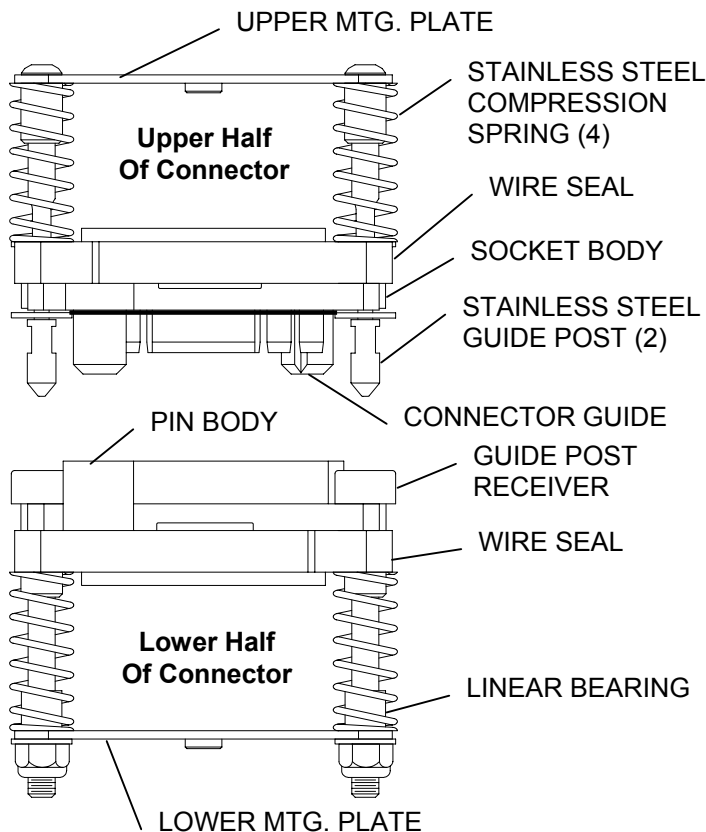

ELECTRICAL DISCONNECT UNIT (EDU) SPECIFICATION GUIDE

- ❖ The coaxial and electrical disconnect unit shall meet or exceed sine vibration tests of 3.5 g's within the frequency range of 5-60 Hz in all three axes for minimum of six 5-minute cycle each axes. It shall meet or exceed random vibration tests of frequency range 60-1000 HZ at .025 g2/Hz applied for 30 minutes in each of the three axes. It shall have results to exhibit no signal or electrical discontinuities greater than 10 microseconds. Tests applicable to Electrical Disconnect Unit and attached components.
- ❖ The EDU shall have a 3-way tracking guide and support. It shall be constructed of precision cast high strength aluminum alloy 356-T6. A permanently fixed position piece incorporating a special tracking guide system permits the moveable portion of the *Disconnect Unit* to align in the same position every time the system is operated, thereby eliminating the need to re-orientate the camera. The Electrical Disconnect Unit shall have twin high strength notches securing the load of the *Lower Contact Assembly* and camera.
- ❖ The MULTI-CONTACT Connector assembly shall be modular for easy installation and retrofit requirements. All pin and socket contacts shall be insertable and removable. The connector shall have a maximum of 16 copper alloy C14500, size 12 contacts (.095" Dia.) rated at 35 Amps with gold plating per MIL-G-45204. All hardware shall be corrosion resistant stainless steel. It shall have a self-aligning and self-adjusting mechanical system comprised of two principal assemblies:
 - Two UPPER CONTACT HALVES* shall house the socket contacts. It shall incorporate spring assisted polymer contact body with precision-machined guideposts. The socket contact body shall have integral guideposts for precise contact alignment.
 - Two LOWER CONTACT HALVES* shall house the pin contacts comprised of spring assisted polymer contact body with precision-machined guidepost receivers. The pin contact body aligns with guideposts of integral socket body guideposts.
- ❖ The EDU cover shall be a one-piece hydro-spun heavy gauge stainless steel. The unit shall have a guidepost constructed of precision cast high strength stainless steel. It shall utilize a cast-in-place guide bar for precise alignment of *Lower Contact Assembly* with the fixed portion of the *EDU*.
- ❖ Connector blocks in pole top junction box and camera junction box are provided by others.

**SPECIFICATIONS FOR OTHER COMPONENTS
FOR POLE MOUNT**

❖ A DISCONNECT UNIT FITTER shall be provided made of heavy duty cast aluminum alloy to fit a 2-3/8 inch (60.3mm) outside diameter *Divided Pipe Arm*. Two U-bolt pipe clamps shall be used to rigidly hold the *Divided Pipe Arm*. The fitter is designed to completely isolate the moving *Control Cable* from the electrical and signal wires. It shall contain a molybdenum impregnated nylon pulley providing high strength and low resistance for the moving *Control Cable*, thereby increasing the life of the cable. The pulley shall have a permanently lubricated bearing.

❖ The system shall have a POLE MOUNTED FITTER made of heavy duty cast aluminum alloy to fit 2-3/8 inch (60.3mm) O.D. *Divided Pipe Arm*. It shall utilize a cast-in-place cable stop to prevent cable connections from entering pulley. It shall contain a molybdenum impregnated nylon pulley with a permanently lubricated bearing. Two U-bolt pipe clamps shall be used to rigidly hold the *Divided Pipe Arm*. The fitter shall be designed to bolt directly to a 4" (101.6mm) Diameter pole top. The system shall have a horizontal divided pipe arm that fits inside and connects the Disconnect Unit Fitter with the Pole Mounted Fitter. It shall be made of 2-3/8 inch (60.3mm) O.D. with 1/4" (6.4mm) wall thickness steel pipe with galvanized finish standard (polyester powder coat painted finish optional). The pipe shall be divided entire length to keep *Control Cable* and electrical/signal wires separate. Arm shall be position aligned non-rotating type incorporating interlocking positioning keys.

❖ The system shall have a POLE TOP CONNECTION BOX made of cast aluminum. The box shall be 8-inch (203mm) diameter with the bottom portion made to fit over a 4" (101.6mm) O.D. Diameter pole top tenon. It shall be secured to the pole using stainless steel set screws. The connection box shall have a cast aluminum cover retained by stainless steel set screws. The box shall incorporate bosses for direct mounting of cord strain relief brackets and cord grips. It shall also be used to terminate the socket connectors at a terminal block located in the pole-top connection box. If preferred, the Signal Cable can be a one piece from disconnect unit to pole base or cabinet to eliminate need of a connector at top of pole.

❖ The system shall utilize a CONTROL CABLE (mechanical raising and lowering cable) made of Stainless Steel 5/32 inch (3.97mm) diameter 7 x 19 construction cable. Minimum breaking strength shall be 2400 lbs. One end of the cable shall have a heavy-duty Stainless Steel connecting link.

❖ The system shall also have a CAMERA CONNECTION BOX. It shall be a two piece design for

easy camera mounting. Both sections shall be made of corrosion resistant cast aluminum. The top half shall be mounted and gasketed to the bottom of the disconnect unit. Inside the top half, it shall have provision to mount additional weights for lightweight cameras or other equipment. All parts shall be made of extra heavy construction. The Camera Connection Box shall be adaptable to all brands of cameras. The two piece construction shall feature a lower box that hinges down for easy access to wiring. It shall contain a large capacity-splicing compartment for camera power, signal leads, and connectors. All hardware shall be made of stainless steel.

❖ An LT-CC LOWERING TOOL shall be supplied with each order. It is a portable lowering tool consisting of the gearbox, disc brake, frame, and lowering cable. The gearbox shall be of heavy-duty design. It shall incorporate solid steel heated treated gears for maximum durability and strength. The gearbox shall be equipped with a special automatically actuated disc brake for load holding ability and the prevention the load from freewheeling. This is essential for all lifting operations. The winch has a 3:1 Gear reduction to reduce the effort required to raise and lower the camera assembly. The frame shall be of a heavy-duty design with brackets making the unit stable when mounted in the pole handhole. It shall have a corrosive resistant powder coat finish. The frame shall have a pulley with a permanently lubricated bearing. The raising and lowering (control) cable shall be made of stainless steel 1/8-inch (3.2mm) diameter 7 x 19 construction. Minimum breaking strength shall be 1760lbs. It shall come with a heavy-duty stainless steel swivel.

The control cable is the only cable that moves when the camera is raised and lowered.

INTERLOCKING ARM & FITTERS
PROVIDES POSITIVE NON-ROTATING POSITIONING
OF PIPE ARM FOR ALL OUTDOOR
POLE AND WALL MOUNTED LOWERING SYSTEMS

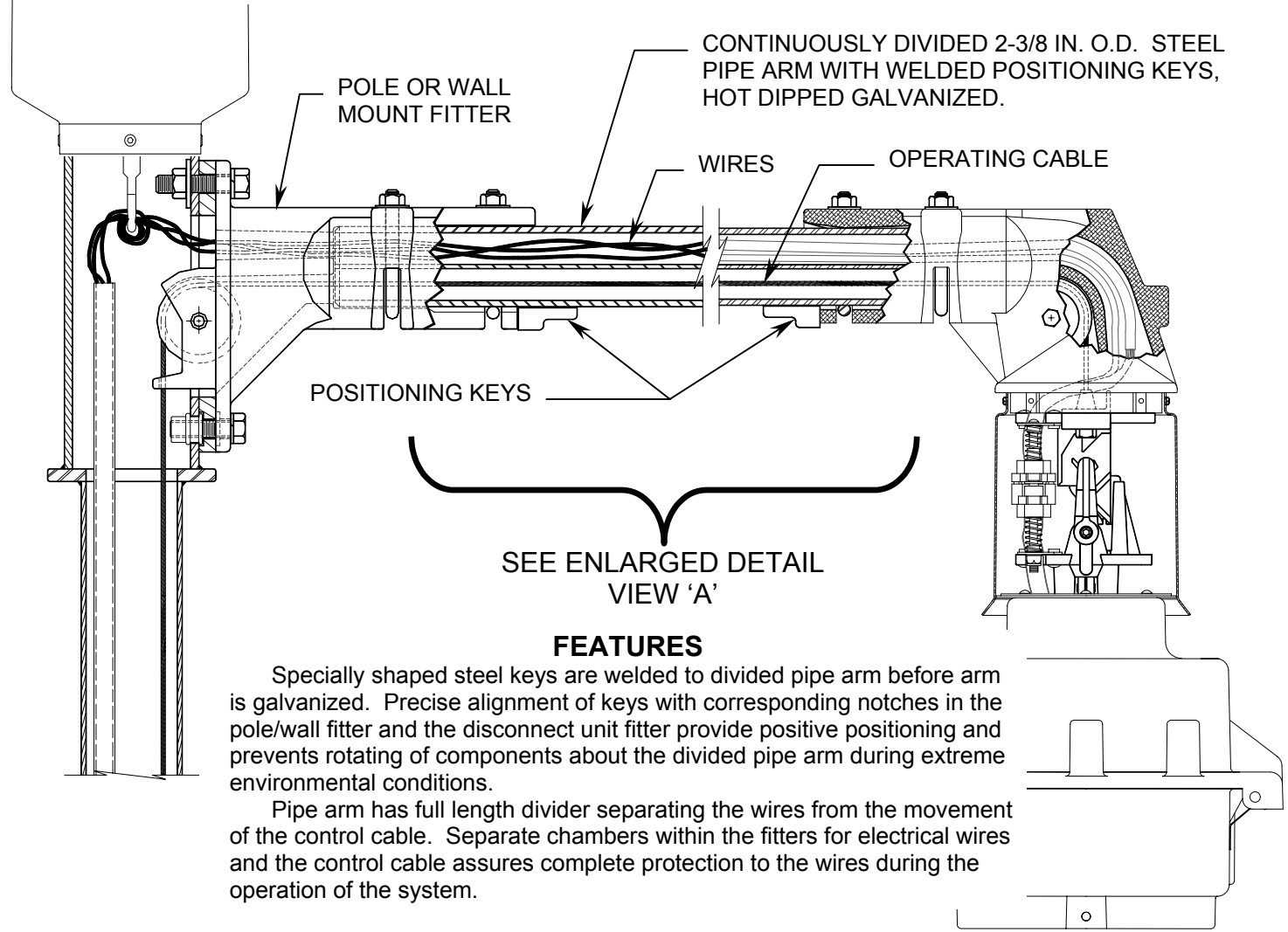

FEATURES

Specially shaped steel keys are welded to divided pipe arm before arm is galvanized. Precise alignment of keys with corresponding notches in the pole/wall fitter and the disconnect unit fitter provide positive positioning and prevents rotating of components about the divided pipe arm during extreme environmental conditions.

Pipe arm has full length divider separating the wires from the movement of the control cable. Separate chambers within the fitters for electrical wires and the control cable assures complete protection to the wires during the operation of the system.

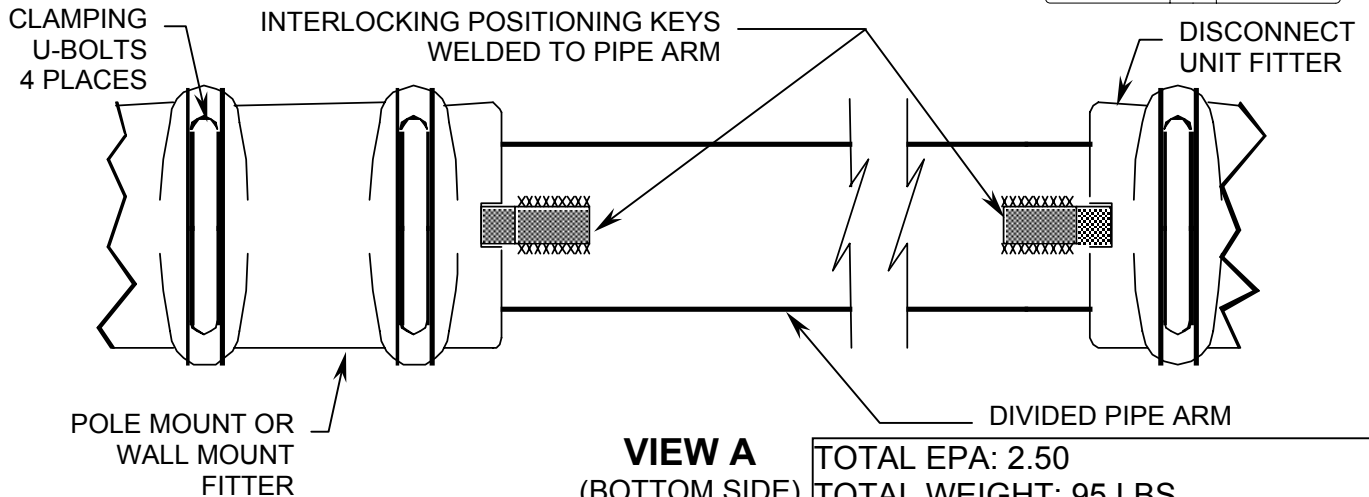

VIEW A
(BOTTOM SIDE)

TOTAL EPA: 2.50
TOTAL WEIGHT: 95 LBS
(includes arm, disconnect unit, pole and camera junction boxes, & camera)

INTERLOCKING ARM & FITTERS
PROVIDES POSITIVE NON-ROTATING POSITIONING
OF PIPE ARM FOR ALL OUTDOOR
POLE AND WALL MOUNTED LOWERING SYSTEMS

ARM CROSS SECTION

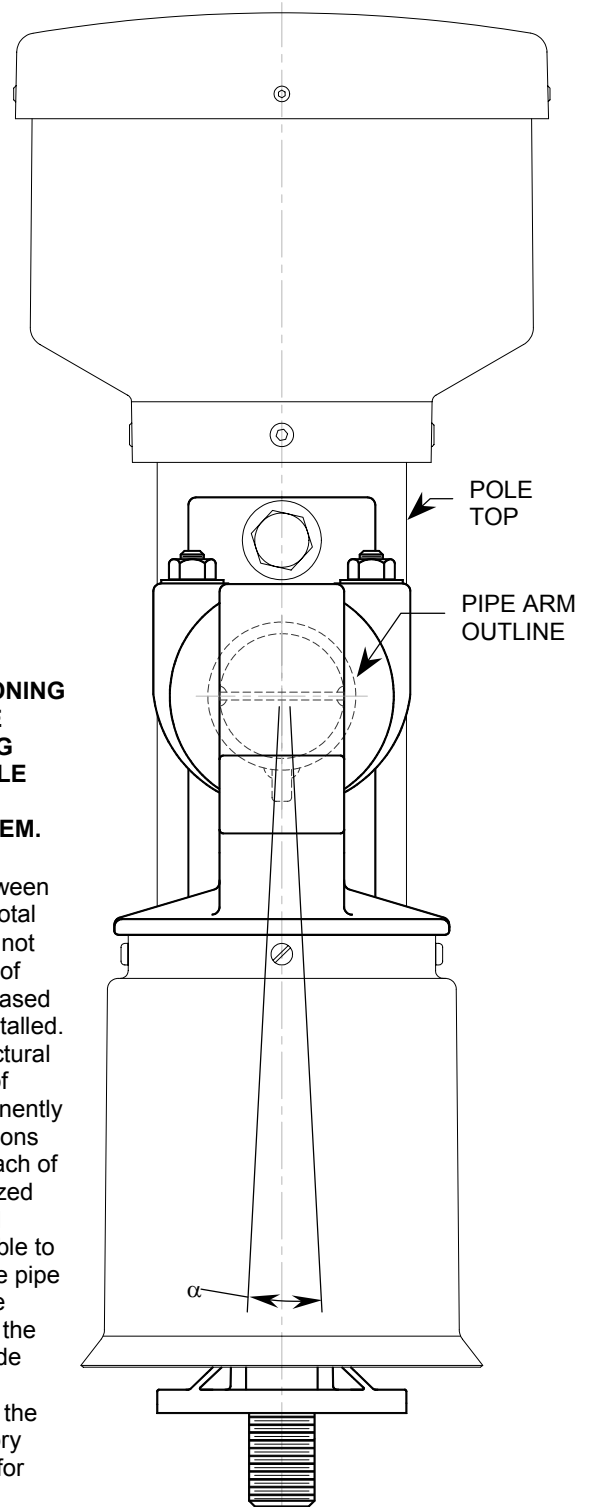
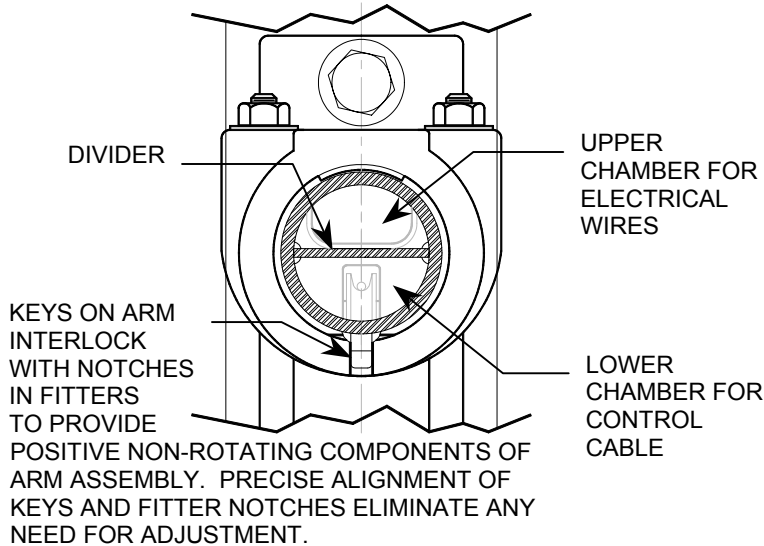

DETAILS OF FEATURES

NOTE: WHEN THE INTERLOCKING POSITIONING KEYS OF THE ARM ASSEMBLY ARE MATED WITH THE CORRESPONDING NOTCHES IN THE FITTERS, THE POLE SHAFT MUST BE PLUMB FOR THE PROPER OPERATION OF THE SYSTEM.

ANGLE α : The angle α shown in the END VIEW is based on mechanical tolerances between mating parts and should not exceed a total of $1/2^\circ$. This deviation from plumb will not affect the operation of the components of the arm assembly. All tolerances are based on the pole shaft being plumb when installed.

PIPE ARM: (See Fig. 1) Constructed of 2 inch structural steel pipe having an outside diameter of 2-3/8 inch. Positioning keys are permanently welded to the pipe arm at precise positions that align with notches in the ends of each of the fitters. Arm finish is hot dip galvanized after all welding is completed. Optional finishes over the galvanizing are available to match the color of the pole. Ends of the pipe arm bottom out against the inside of the fitters a small fraction of an inch before the keys bottom out in the notches to provide a secure fit.

The pipe arm is installed complete with the rest of the arm components at the factory and is pre-wired to eliminate any need for adjustment in the field.

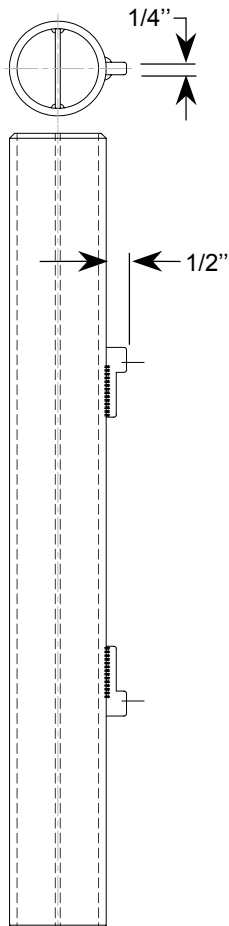
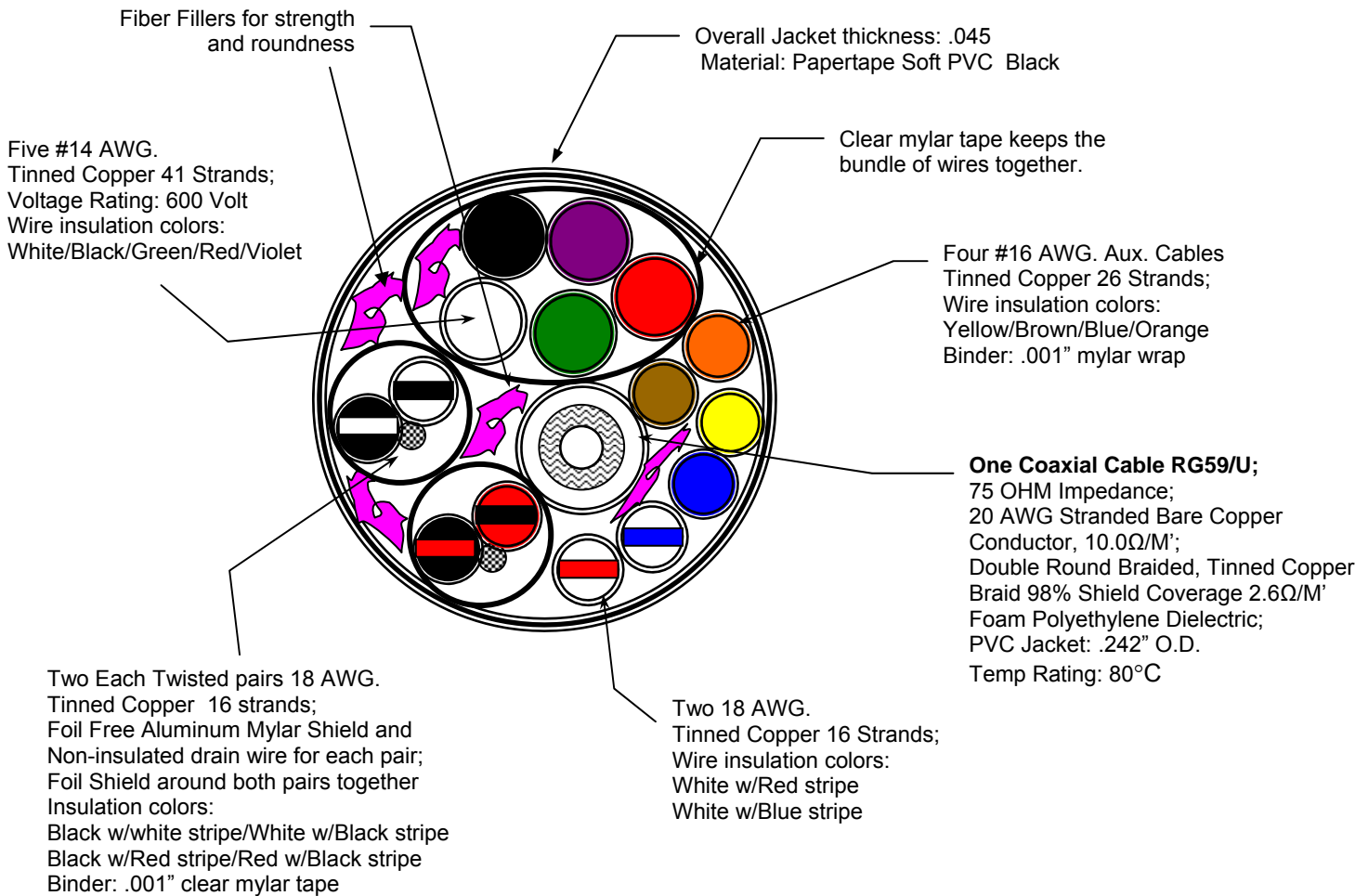

Fig. 1

Composite Cable for **16HD-A** connector

Composite Signal Cable containing:
 1-RG59/U COAX with #20 AWG Stranded Center Conductor
 1-#18 AWG TWISTED PAIR WITH DRAIN IN FOIL SHIELD
 1-#18 AWG TWISTED PAIR WITH DRAIN IN FOIL SHIELD
 2-#18 AWG AUXILIARY CABLES
 4-#16 AWG AUXILIARY CABLES
 5-#14 AWG POWER CABLES
 CABLE LENGTH PER ASSEMBLY: **AS REQUESTED**



ADDITIONAL CABLE SPECS:

- VOLTAGE RATING FOR 14 AWG WIRE INSULATION: 600 V.
- **UL** and **CSA** approved cable.
- PART NUMBER '**663-224-RG59-16**', E24546 **UL** AWM STYLE 2464, **CSA** LL15758 AWM A/II 90°C 300V FT1 -4/C 16 AWG + 2/PR 18 AWG + 2/C 18 AWG +5/C 14AWG + 1/C 20 AWG 80°C 300V VW-1 (PRINTED ON OUTSIDE OF JACKET).
- JACKET MATERIAL: .045 thick soft PVC
- FILLERS A MUST AND WRAPS AS REQUIRED.

Composite Cable Cord Grip

662-240-28 SUPPORT GRIPS Standard Duty, Closed Mesh

Standard closed mesh support grips are designed for loads up to 600 lbs. and vertical runs of up to 100ft. The 662-240-28 are used to support electrical/signal cable with a cable diameter ranging from 0.75" to 0.99". Closed mesh support grips have a loop to hang from the eye hook. Support grips are woven of corrosion-resistant tinned-bronze wire.

Optional **662-240-38** stainless steel wire mesh also available



Cable Diameter Range	Part Number	Bale Length	Mesh Length	Approximate Break Strength	Material
0.750-0.990"	662-240-28	8"	14"	1300 LBS	Tinned-bronze
0.750-0.990"	662-240-38	8"	14"	1300 LBS	Stainless Steel

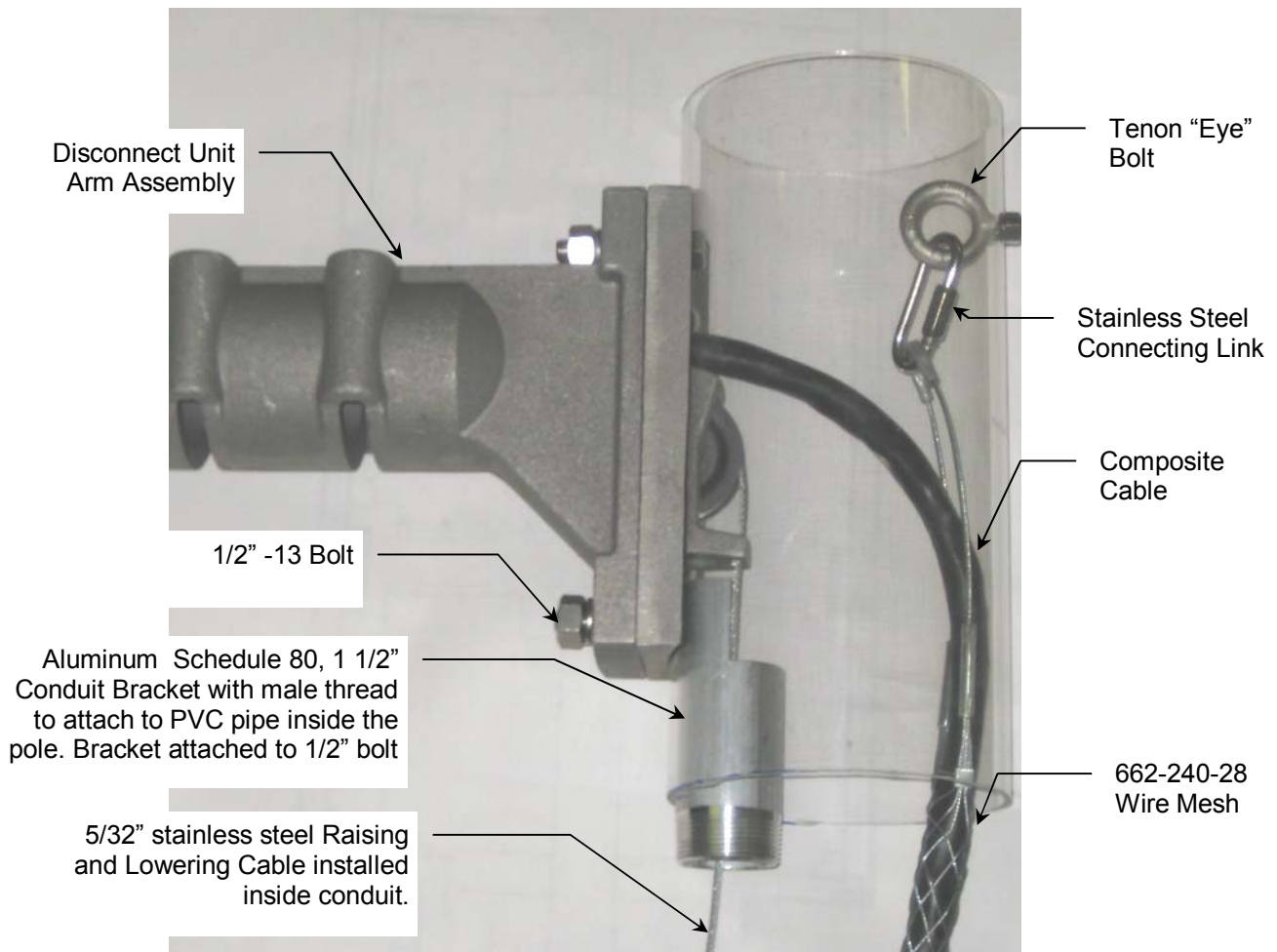

Design **CDP4-16HDA** SERIES
Pole Mounting Disconnect Unit
Measurements

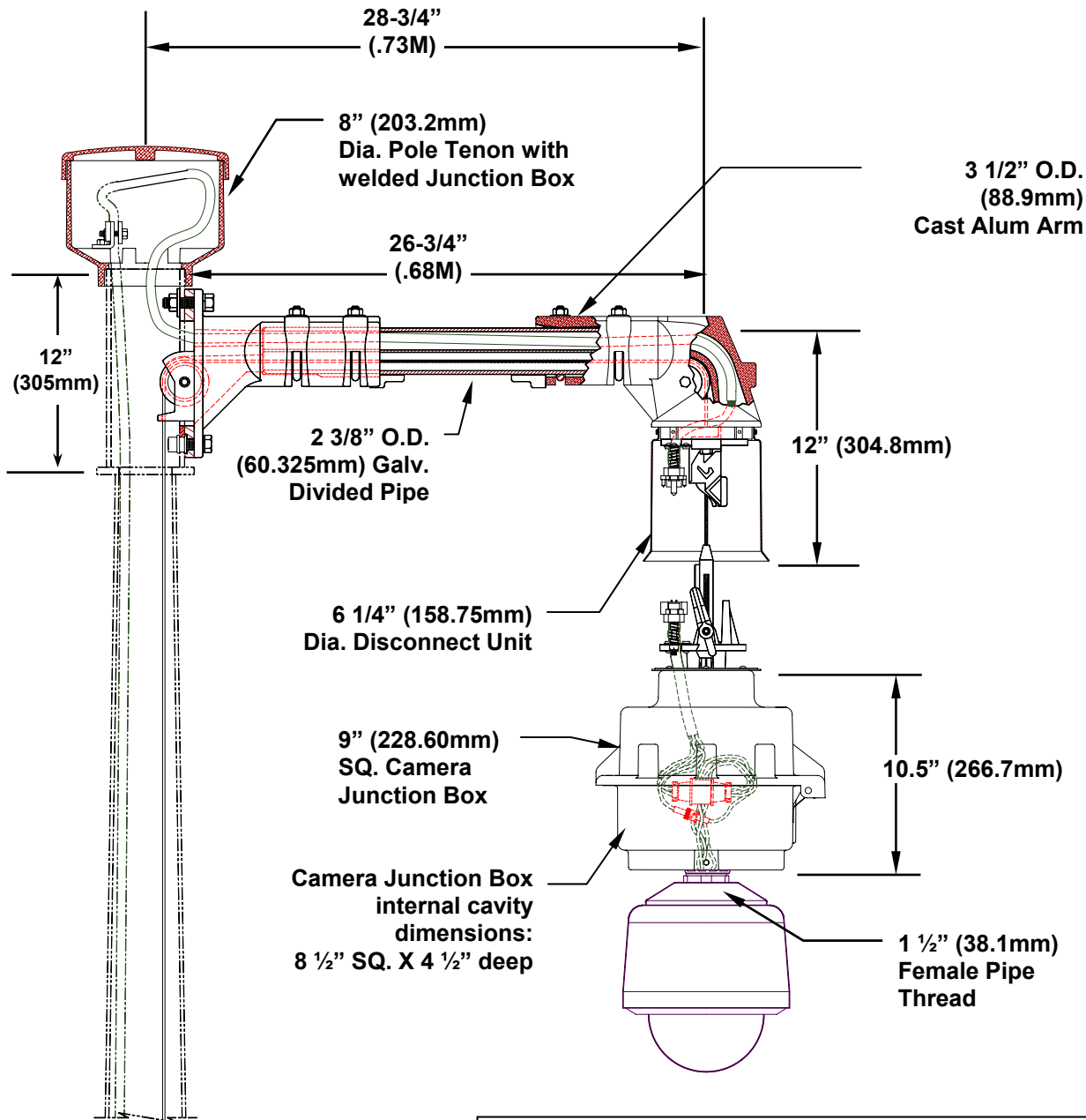

Wind load Rating: 120mph (195kmph) w/1.3 Gust with 1.65 safety factor
Load Capacity: 200 lbs (91kgs) with safety factor of 5:1
 100 lbs (45.5 kgs) with safety factor of 10:1
Total EPA: 2.50
Total Weight: 95 lbs (43 kgs)
 (Includes arm, disconnect unit, camera junction box, pole top junction box, and camera)

Design **CDP4-16HDA** SERIES
Pole Mounting Disconnect Unit
Measurements

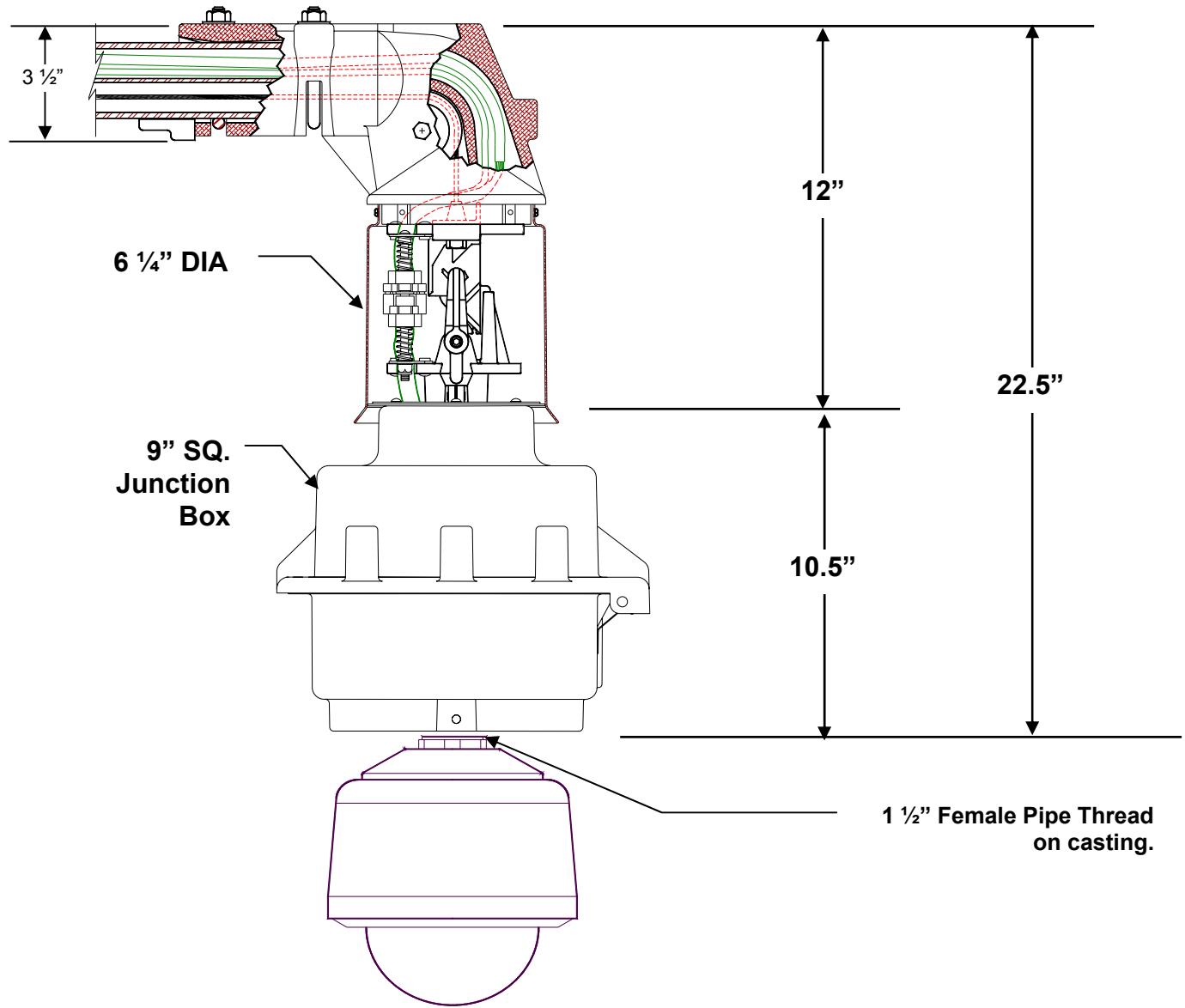

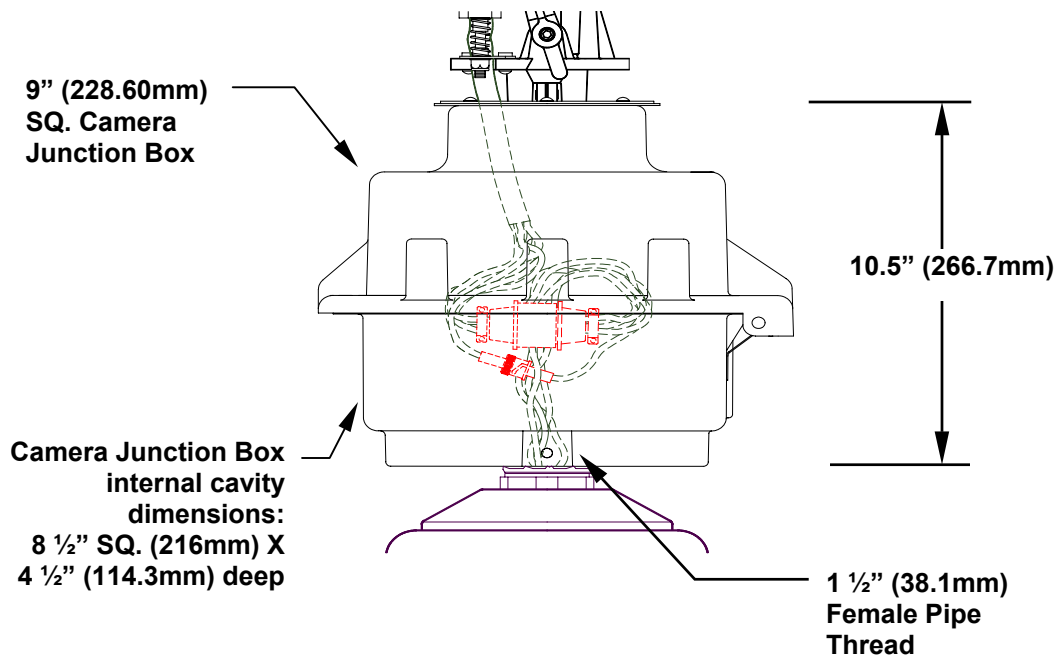

The Camera Junction Box shall be a two piece design for easy camera mounting.

- Both sections shall be made of corrosion resistant cast aluminum.
- The top half shall be mounted and gasketed to the bottom of the disconnect unit. It shall extend into the cylinder of the disconnect unit and designed to repel water
- Inside the top half, it shall have provision to mount additional weights for lightweight cameras or other equipment.
- All parts shall be made of extra heavy construction.
- The Camera Connection Box shall be adaptable to all brands of cameras.
- The two piece construction shall feature a lower box that hinges down for easy access to wiring. It shall contain a large capacity-splicing compartment for camera power, signal leads, and connectors.
- All hardware shall be made of stainless steel.

